

CATALOGO PARTI DI RICAMBIO - PARTS CATALOG
CATALOGUE PIECES DE RECHANGE - ERSATZTEILKATALOG
CATALOGO PIEZAS DE REPUESTO

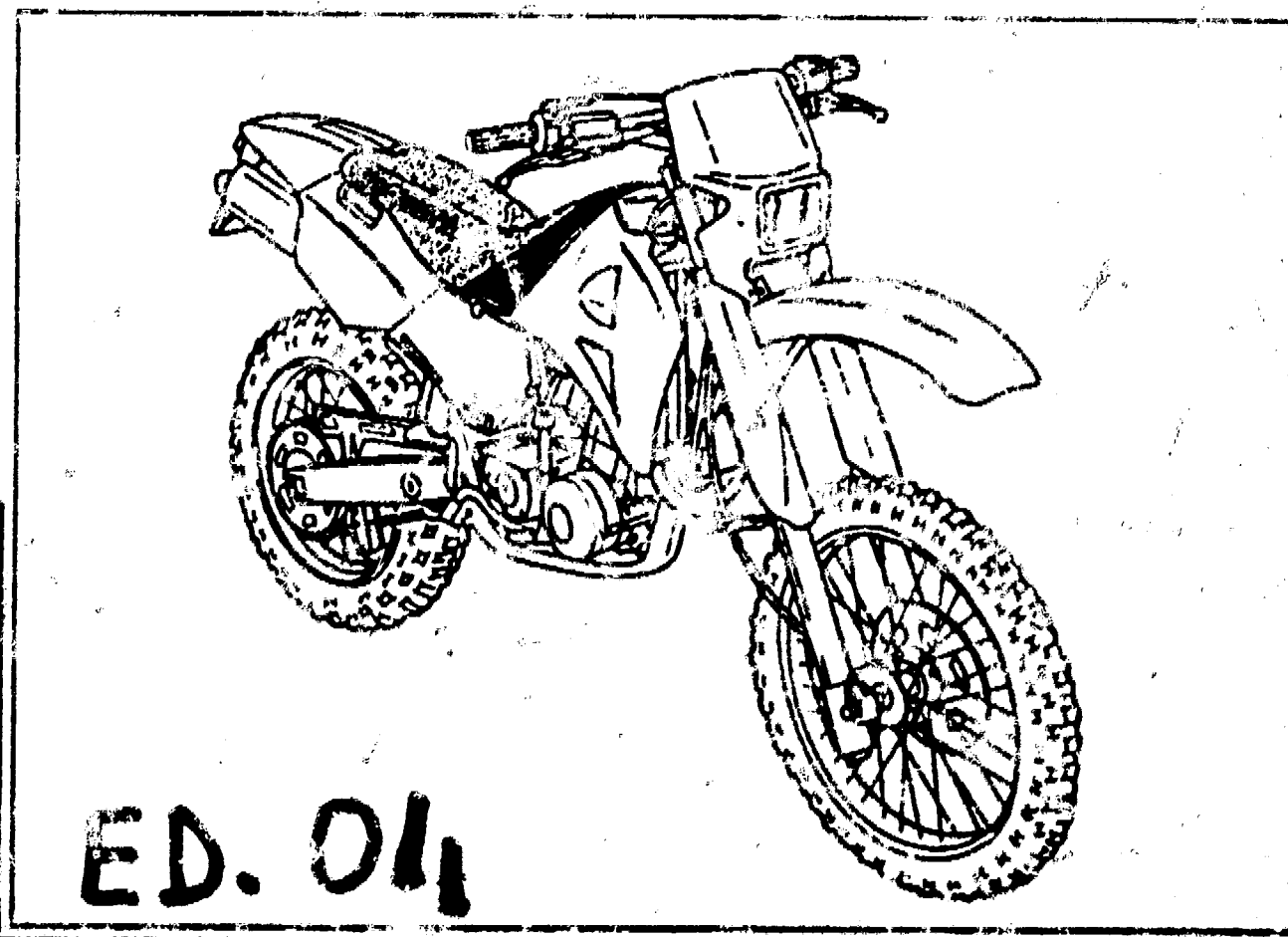

ED. 04

Husqvarna TE - TC 610 / 95

Part. N. 8000 70882

INFORMAZIONI GENERALI

Il presente catalogo serve per richiedere con esattezza le parti di ricambio.

Nelle ordinazioni indicare:

- 1) il numero di codice del particolare seguito dalla descrizione;
 - 2) il colore per i pezzi verniciati o comunque colorati;
 - 3) il numero di matricola del motociclo, stampigliato sul corno di sterzo.
- Le indicazioni destra e sinistra si riferiscono ai lati del veicolo rispetto al senso di marcia.

GENERAL INFORMATION

The present spare parts list enables one to order exactly the right spare parts.

When ordering specify:

- 1) the part's code number followed by its description;
 - 2) indicate colour for painted or coloured parts;
 - 3) the motorcycle's serial number, stamped on the steering head.
- References to right and left apply to the vehicle in terms of its direction of movement.

INFORMATIONS GENERALES

Ce catalogue permet de commander correctement les pièces de rechange.

Les commandes doivent être passées en indiquant:

- 1) le numéro de code des pièces détachées suivi de leur description;
 - 2) la couleur des pièces peintes ou colorés;
 - 3) le matricule de la moto, estampillé sur la tige du guidon.
- Droite et gauche sont les côtés du véhicule par rapport au sens de la marche.

ALLGEMEINE HINWEISE

Dieser Ersatzteilkatalog dient zur genauen Angabe der Teile bei Ersatzteilbestellungen.

Bei Ersatzbestellung ist folgendes anzugeben:

- 1) Die Bestellnummer der Ersatzteile mit der entsprechenden Beschreibung;
 - 2) Farbe für lackierte und farbige Teile angeben;
 - 3) Die Seriennummer des Motorrads, die am Lenkrohr eingepreßt ist.
- Die Angaben rechts und links beziehen sich auf das Fahrzeug in Fahrrichtung.

INFORMACIONES GENERALES

El presente catálogo sirve para pedir con exactitud las partes de recambio.

En los pedidos se debe indicar:

- 1) el número de código de la parte y a continuación la descripción;
 - 2) el color para las piezas barnizadas o coloreadas;
 - 3) el número de matrícula de la motocicleta, estampado en el tubo de dirección.
- Las indicaciones derecha e izquierda se refieren a los lados del vehículo respecto del sentido de marcha.

NOTE - LIST - NOTES - NOTE - NOTAS:

F.m. : Fino alla matricola - Until V.I.N. - Jusqu'au matricule - Bis zu Matrikel - Hasta la matricula
 D.m. : Dalla matricola - From V.I.N. - Du matricule - Vom Matrikel - Desde la matricula
 Z : n° denti, number of teeth, numéro dents, Zähne nummer, número dientes

A : Austria, Austria, Autriche, Österreich, Austria
 AUS : Australia, Australia, Australie, Australien, Australia
 B : Belgio, Belgium, Belgique, Belgien, Bélgica
 BR : Brasile, Brazil, Brésil, Brasilien, Brasil
 CND : Canada, Canada, Canada, Kanada, Canada
 CH : Svizzera, Switzerland, Suisse, Schweizer, Suiza
 D : Germania, Germany, Allemagne, Deutschland, Alemania
 E : Spagna, Spain, Espagne, Spanien, España
 F : Francia, France, France, Frankreich, Francia
 GB : Gran Bretagna, Great Britain, Grand Bretagne, Groos Britan, Gran Bretaña
 I : Italia, Italy, Italie, Italien, Italia
 TA : Tahiti, Tahiti, Tahiti, Tahiti, Tahiti
 USA : Stati Uniti d'America, United States of America, Etats Unis d'Amérique, Vereinigte Staaten von Amerika, Estados Unidos
 SF : Finlandia, Finaid, Fintande, Finland, Finlandia

Il n° di matricola iniziale del modello TE 610 / 95 è 8AE005162

Il n° di matricola iniziale del modello TC 610 / 95 è 8AE050606

The initial serial number for the TE 610 / 95 model is 8AE005162

The initial serial number for the TC 610 / 95 model is 8AE050606

Le matricule initial du modèle TE 610 / 95 est 8AE005162

Le matricule initial du modèle TC 610 / 95 est 8AE050606

Die Seriennummer des Modells TE 610 / 95 beginnt mit 8AE005162

Die Seriennummer des Modells TC 610 / 95 beginnt mit 8AE050606

El n° de matricula inicial de la motocicleta TE 610 / 95 es 8AE005162

El n° de matricula inicial de la motocicleta TC 610 / 95 es 8AE050606

Dati indicativi soggetti a modifiche senza impegno di preavviso.

All data are subject to modification without prior notice.

Données indicatif sujet au modifications sans obligation de préavis.

Änderungen vorbehalten.

Datos indicativos sujetos a modificaciones sin compromiso de preaviso.



Tavola
Drawing
Table
Bijl
Table

	Denominazione	Description	Designation	Bezeichnung	Denominacion	Pag
1	ATTREZZI DI ASSISTENZA	SERVICE TOOLS	OUTILS D'ASSISTANCE	HILFAUSRÜSTUNG	HERRAMIENTAS DE ASISTENCIA	5
2	TESTA, CILINDRO	CYLINDER HEAD, CYLINDER	CULASSE, CYLINDRE	ZYLINDERKOPF, ZYLINDER	CULATA, CILINDRO	7
3	DISTRIBUZIONE	VALVE TIMING	DISTRIBUTION	VENTILSTEUERUNG	DISTRIBUCION	13
4	PISTONE, MANOVELLISMO	PISTON, CRANKSHAFT	PISTON, VILEBREQUIN	KOLBEN, KURBELWELLE	PISTON, PALANCAS	17
5	RAFFREDDAMENTO	COOLING	REFROIDISSEMENT	WASSERKÜHLUNG	ENFRIAMIENTO	19
6	SEMICARTER DESTRO	R.H. HALF CRANKCASE	CARTER D.	GEHAUSEDECKEL R.	BANCADA DER.	23
7	SEMICARTER SIN., AVVIAMENTO	L.H. HALF CRANKCASE, STARTING	CARTER G., DEMARRAGE	GEHAUSEDECKEL L., ANLASSER	BANCADA IZQ., ARRANQUE	27
8	CAMBIO, COMANDO CAMBIO, FRIZIONE - Modello TE	TRANSMISSION, SHIFTER, CLUTCH - TE Model	BOITE DE VITESSE, COMMANDE DE VITESSE, EMBRAYAGE - Modèle TE	WECHSELGETRIEBE, GANG - SCHALTUNG, KUPPLUNG - Modell TE	CAMBIO, MANDO CAMBIO, ENBRAGUE - Modelo TE	33
8A	CAMBIO, COMANDO CAMBIO, FRIZIONE - Modello TC	TRANSMISSION, SHIFTER, CLUTCH - TC Model	BOITE DE VITESSE, COMMANDE DE VITESSE, EMBRAYAGE - Modèle TC	WECHSELGETRIEBE, GANG - SCHALTUNG, KUPPLUNG - Modell TC	CAMBIO, MANDO CAMBIO, ENBRAGUE - Modelo TC	39
9	ACCENSIONE	IGNITION	ALLUMAGE	ZÜNDUNG	ENCENDIDO	43
10	CARBURATORE - Modello TE	CARBURETOR - TE Model	CARBURATEUR - Modèle TE	VERGASER - Modell TE	CARBURADOR - Modelo TE	45
10A	CARBURATORE - Modello TC	CARBURETOR - TC Model	CARBURATEUR - Modèle TC	VERGASER - Modell TC	CARBURADOR - Modelo TC	51
11	FILTRO ARIA	AIR FILTER	FILTRE AIRE	AIRFILTER	FILTRO DE AIRE	57
12	TELAIO, PEDANE	FRAME, FOOT RESTS	CHÂSSIS, REPOSE PIEDS	RAHMEN, FUSSPODT	BAJICHO, REPOSAPIES	59
13	SOSPENSIONE ANTERIORE	FRONT FORK ASSEMBLY	SUSPENSION AVANT	VORDERTELESKOPFAHRE	SUSPENSION DELANTERA	63
14	FORCELLONE	SWING ARM	FOURCHE	GABEL	FORQUILLA	69
15	AMMORTIZZATORE POSTERIORE	REAR SUSPENSION	SUSPENSION ARRIERE	HINTERFAHRGANG	SUSPENSION TRASERA	75
16	LEVERAGGI SOSPENSIONE POST.	REAR SUSPENSION LINKAGE	LEVIER SUSPENSION ARRIERE	HEBEL SUSPENSION ARRIERE	LEVANTICA SUSPENSION TRASERA	79
17	MANUBRIO E COMANDI	HANDLEBAR AND CONTROLS	GUIDON ET COMMANDES	LENKER UND STEUERUNGS- EINRICHTUNGEN	MANILAR Y MANDOS	81
18	FRENO IDRAULICO POSTERIORE	REAR HYDRAULIC BRAKE	FREIN HYDRAULIQUE ARRIERE	HINTERBREMSE	FRENO HIDRAULICO TRASERO	83
19	PANNELLI, PARAFANGHI, SELLA	PANEL, FENDERS, SEAT	PANNEAU, GARDE-BOUES, SIEGE	STREIFEN, KOTFLÜGEL, SATTEL	PANELES, GUARDABARROS, SILLIN	87
20	SERBATOIO	GAS TANK	RESERVOIR	KRAFTSTOFFBEHALTER	DEPOSITO	91
20A	SERBATOIO MAGGIORATO	LARGE GAS TANK	RESERVOIR DE PULS GRANDE CAPACI- UEBERDIMENSIONNIERTER BEHALTER	ÜBERDIMENSIONNIERTER BEHALTER	DEPOSITO AMPLIADO	93
21	SCARICO	EXHAUST SYSTEM	TUYAU D'ÉCHAPPEMENT	AUSPUFFROHR	TUBO DE ESCAPE	95
22	FRENO IDRAULICO ANTERIORE	FRONT HYDRAULIC BRAKE	FREIN HYDRAULIQUE AVANT	VORTERBREMSE	FRENO HIDRAULICO DELANTERO	97
22A	RUOTA ANTERIORE	FRONT WHEEL	ROUE AVANT	VORERRAD	RUEDA DELANTERA	99
23	RUOTA POSTERIORE	REAR WHEEL	ROUE ARRIERE	HINTERRAD	RUEDA TRASERA	103
24	CONTACHILOMETRI, LIBRETTO USO E MANUTENZIONE, AVVIS. ACUSTICO	SPEEDOMETER, OWNER'S MANUAL, HORN	COMPTE-KILOMETRES, EMPLOI D'ENTRETIEN, SIGNAL ACOUSTIQUE	TACHOMETER, BETRIEBSANLEITUNG, BREMSSCHEIBENSCHUTZ, HUPPE	CUENTA KILOMETROS, FOLLETO DE INSTRUCCIONES, AVISADOR ACUSTICO	107
25	IMPIANTO Elett., PORTATARGA PORTANUMERO	ELECTRIC SYSTEM, PLATE HOLDER NUMBER HOLDER	INSTALLATION ELECT., PORTE-BALAI PORTE-NOMBRE	ELEKTR. ANLAGE, SCHILDTRÄGER NUMMERTRÄGER	INSTALAC. ELECT., PORTA-MATRICULA PORTA NÚMERO	109
26	FRECCE - Modello TE	BLINKER - TE Model	CLIGNOTANT - Modèle TE	BLINKER - Modell TE	INTERMITENTE - Modelo TE	113
27	DECALCOMANIE - Modello TE	TRANSFER - TE Model	DECALCOMANIE - Modèle TE	ABZIEHBILD - Modell TE	CALCOMANIA - Modelo TE	115
28	DECALCOMANIE - Modello TC	TRANSFER - TC Model	DECALCOMANIE - Modèle TC	ABZIEHBILD - Modell TC	CALCOMANIA - Modelo TC	117

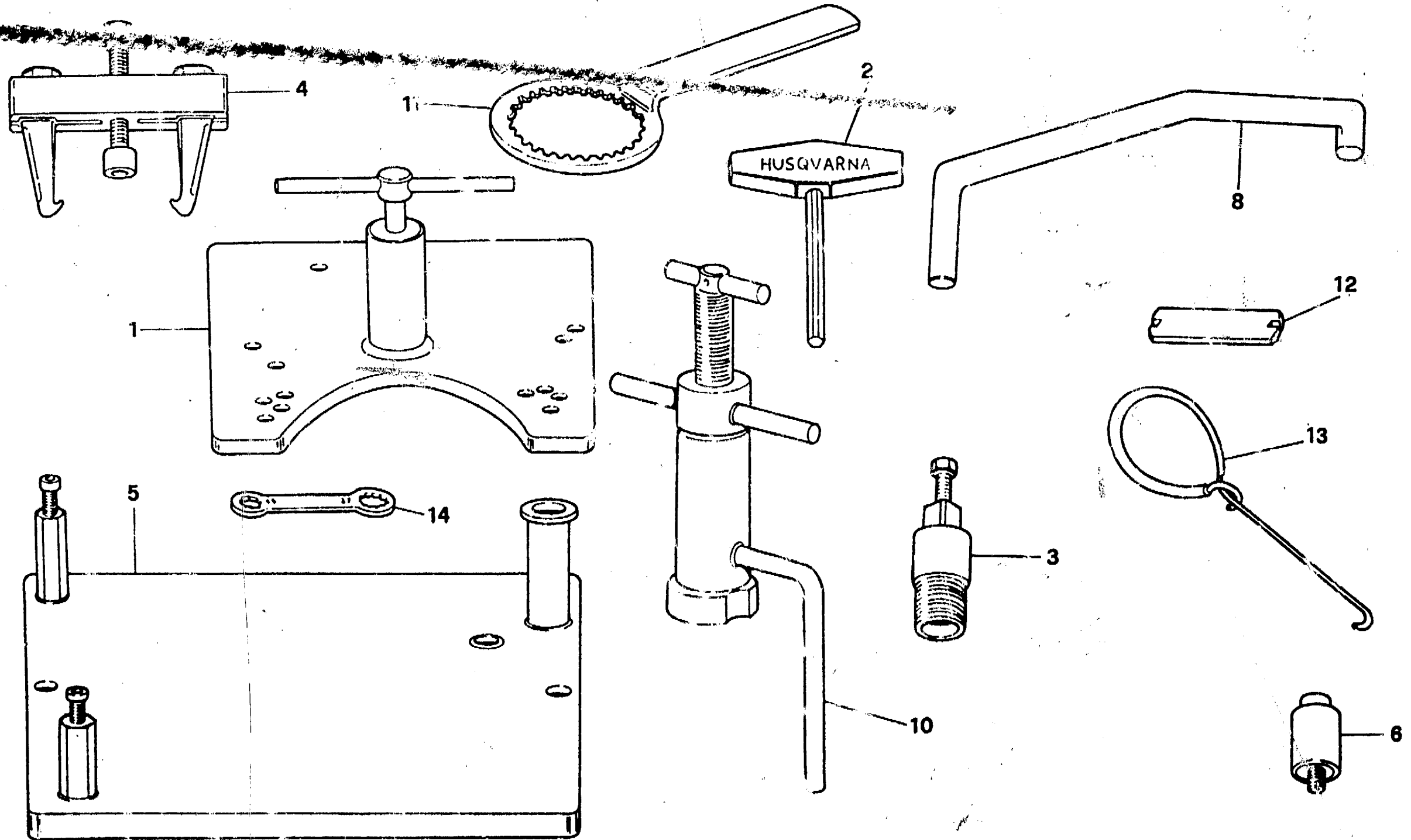



ATTREZZI DI ASSISTENZA - SERVICE TOOLS
OUTILS D'ASSISTANCE - HILFAUSRUSTUNG
HERRAMIENTAS DE ASISTENCIA

TAVOLA
DRAWING
TABLE
BILD
TABLA

1

TE - TC
610 / 95

Note Notes Marka Notas	Pos. No. N. Index Pos.	N. Cod. Code No. Nr. Code Code Nr N. Cod.	DENOMINAZIONE	NAME	DESIGNATION	BESCHREIBUNG	DENOMINACION	Q.tà Qty Q.tà M.ge C.ad	Validità Validity Validez Gültig Validez
	1	1517947-01	Estrattore basamento	Crankcase puller	Extracteur carter	Kurbelgehäuse-Auszieher	Extractor cárter	1	
	2	1519653-01	Chiave per esagono incassato	Allen wrench	Clé hexagonale	Sechskanteinsteckschlüssel	Llave de Allen	1	
	3	1615133-02	Estrattore volante	Flywheel extractor	Extracteur pour volant	Auszieher für Schwungrad	Extractor volante	1	
	4	1519805-01	Estratt. ingranaggio lato frizione	Clutch gear puller	Extract. engr. côté embrayage	Auszieher Kupplungszahnrads	Extr. engran. lado fricción	1	
	5	1515591-01	Supporto per montaggio	Support for assy	Support pour montage	Halterung für Montage	Soporte por el montaje	1	
	6	1514134-01	Estrattore braccio oscillante	Swing arm puller	Extract. bras oscillant	Schwingarm-Abzieher	Extractor brazo oscilante	1	
	8	1517949-02	Attrezzo per volante	Tool for flywheel	Outil pour volant	Vorrichtung für Schwungrad	Herramienta para volante	1	
	10	8000 70637	Attrezzo mont. albero motore nel carter sinistro	Installing tool, crank shaft left	Outil pour montage vilebrequin dans le demicarter G.	Werkzeug für Montage der Kurbelwelle im L. Gehäuse	Herramienta mont. eje motor en el carter izq.	1	
	11	8000 39524	Chiave di fermo mozzo frizione	Clutch hub retaining wrench	Cléf d'arret moyeau embrayage	Halterungsschlüssel der Kupplungsnahe	Llave bloquear cubo fricción	1	
	12	1519082-01	Chiave per nipples	Wrench for nipples	Clé pour nipple	Schlüssel für nipple	Llave para nipple	1	
	13	1519847-01	Gancio per molle	Spring hook	Crochet pour ressort	Federhaken	Gancho para resorte	1	
	14	8000 6680z	Chiave poligonale	Box wrench	Clé polygonale	Sechskantschlüssel	Llave poligonal	1	

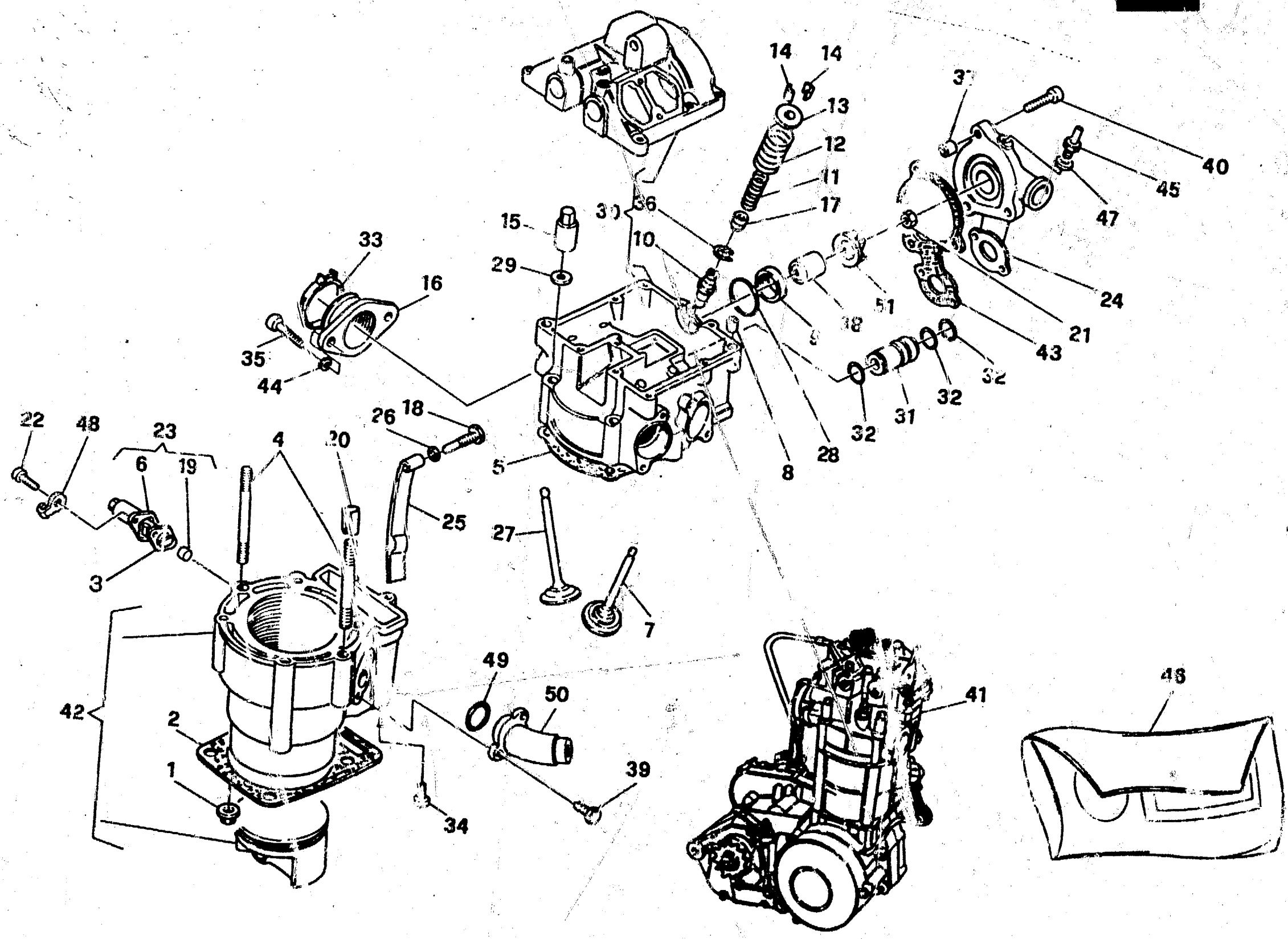



TESTA, CILINDRO - CYLINDER HEAD, CYLINDER
CULASSE, CYLINDRE - ZYLINDERKOPF, ZYLINDER
CULATA, CILINDRO

TAVOLA
DRAWING
TABLE
BILD
TABLA

2

TE - TC
610 / 95

Notes Notes Notas	Pos. No. N.º	N. Cod. Code No. Nr. Code Code Nr. N. Cod.	DENOMINAZIONE	NAME	DESIGNATION	BESCHREIBUNG	DENOMINACION	Q.tà Qty St.ge C.ad	Validità Validity Validité Gültig Validez
	1	61N1 15195	Dado	Nut	Ecrou	Mutter	Tuerca	2	
	2	1615407-02	Guarnizione	Gasket	Garniture	Dichtung	Junta	1	
	3	1615358-01	Guarnizione	Gasket	Garniture	Dichtung	Junta	1	
	4	1615332-01	Prigioniero	Stud bolt	Prisonnier	Stiftschraube	Prisionero	2	
	5	8000 64726	Guarnizione	Gasket	Garniture	Dichtung	Junta	1	
	6	8000 67744	Tenditore	Tensioner	Tendeur	Zylinderspanner	Tensor	1	
	7	8000 66428	Valvola scarico	Exhaust valve	Soupape d'échappement	Auslass-Ventil	Válvula de escape	2	
	8	1611708-01	Bussola	Bushing	Douille	Buchse	Manguito	2	
	9	8000 63817	Bussoia	Bushing	Douille	Buchse	Manguito	1	
	10	1615204-01	Guidavalvola	Valve guide	Guide-soupape	Ventilführung	Guía-válvula	4	
	11	1615288-01	Molla interna	Spring	Ressort	Feder	Resorte	4	
	12	1615025-01	Molla esterna	Spring	Ressort	Feder	Resorte	4	
	13	1615296-01	Scodellino	Cup	Cuvette	Teller	Cubeta	4	
	14	1615023-01	Semicorno	Half cone	Demi-cône	Halb Kegel	Semi-cono	8	
	15	1615351-01	Dado	Nut	Ecrou	Mutter	Tuerca	4	
	16	1615208-01	Raccordo	Union	Raccord	Anschluss	Empalme	1	
+	17	1615303-01	Anello di tenuta	Seal ring	Bague d'étanchéité	Dichtungsring	Anillo de retención	4	
+	17	8000 75584	Anello di tenuta	Seal ring	Bague d'étanchéité	Dichtungsring	Anillo de retención	4	
	18	1615319-02	Vite	Screw	Vis	Schraube	Tomillo	1	
	19	8000 61905	Distanziale	Spacer	Entretoise	Distanzstück	Separador	1	
	20	8000 47700	Spina elastica	Pin	Coupille	SMI	Clavija	2	
	21	8000 42271	Dado	Nut	Ecrou	Mutter	Tuerca	1	
	22	60N10 7335	Vite	Screw	Vis	Schraube	Tomillo	2	
	23	8000 68908	Tenditore completo	Complete tensioner	Tendeur complet	Zylinder spanner	Tensor completo	1	
	24	8000 75766	Corpo pompa	Pump body	Corps pompe	Pumpenkörper	Corpo bomba	1	
	25	8000 66807	Platino catena	Chain slider	Glissière	Gleitbahn	Plato cadena	1	

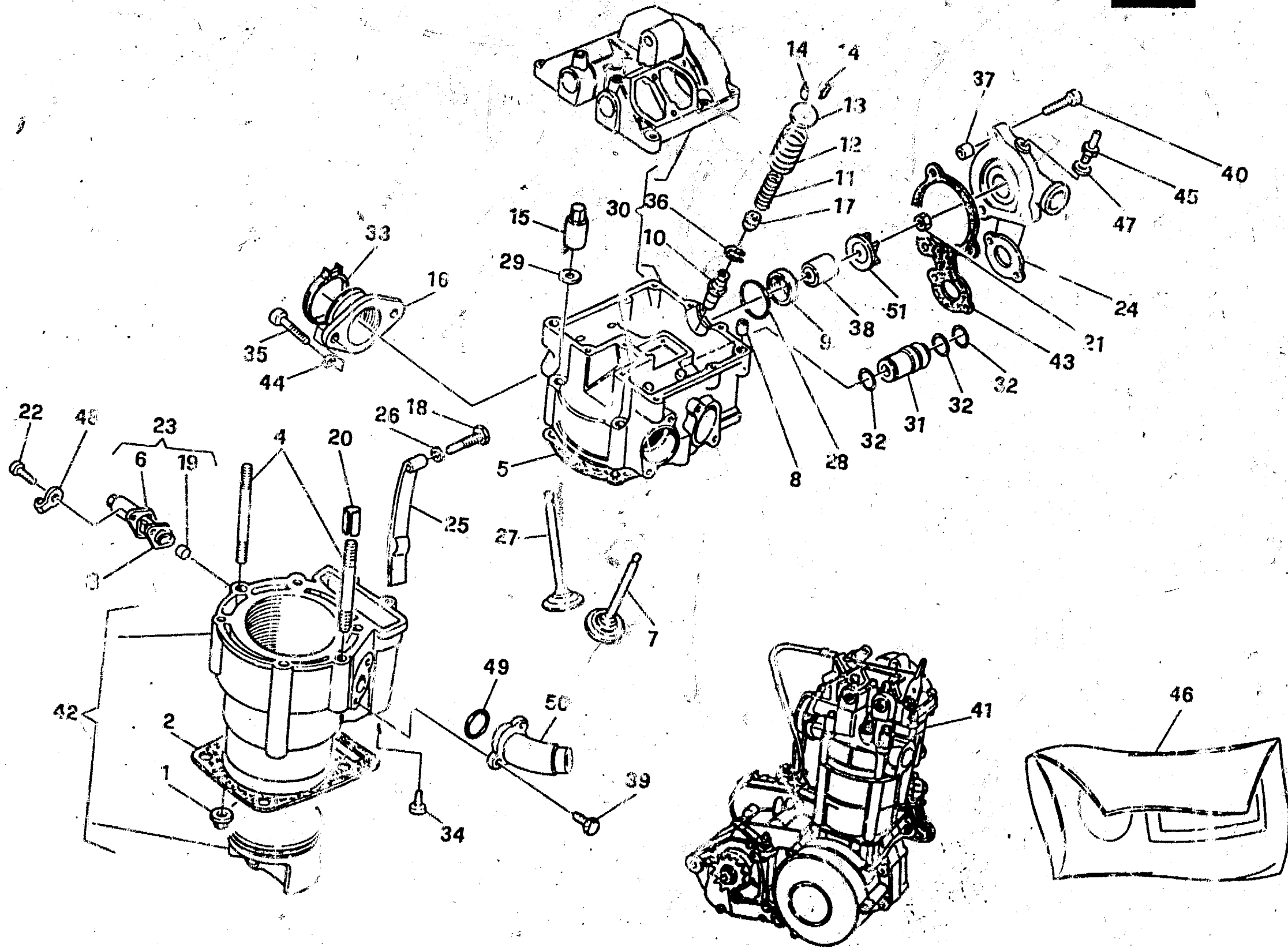



TESTA, CILINDRO - CYLINDER HEAD, CYLINDER
 CULASSE, CYLINDRE - ZYLINDERKOPF, ZYLINDER
 CULATA, CILINDRO

TAVOLA
 DRAWING
 TABLE
 BILD
 TABLA

2

TE - TC
 610 / 95

Note Notas Notas	Pos. No. N.°	N. Cod. Code No. Nr. Code Code Nr. N. Cod.	DENOMINAZIONE	NAME	DESIGNATION	BESCHREIBUNG	DENOMINACION	Q.tà Qty Q.té Menge Cant.	Valità Validity Validez Gültig Validez
	26	8000 45194	Rosetta piana	Washer	Rondelle	Scheibe	Arandela	1	
	27	8000 66427	Valvola aspirazione	Inlet valve	Group admission	Einlassventil	Válvula aspiración	2	
	28	8000 59942	Anello OR	O-Ring	Bague OR	O-Ring	Anillo OR	1	
	29	8000 69156	Rosetta piana	Washer	Rondelle	Scheibe	Arandela	4	
○	30	8000 82507	Coperchio e testa	Cover and head	Couvercle et culasse	Dekel und Zylinderkopf	Tapa e culata	1	
	31	8000 78765	Tubetto	Pipe	Tuyau	Rohr	Tubo	1	
○	31	8000 78765	Tubetto	Pipe	Tuyau	Rohr	Tubo	1	
	32	8000 18422	Anello OR	O-Ring	Bague OR	O-Ring	Anillo OR	3	
	33	8000 60558	Fascetta	Clamp	Collier	Schelle	Banda	1	
	34	60110 2510	Vite	Screw	Vis	Schraube	Tomillo	2	
	35	60110 2557	Vite	Screw	Vis	Schraube	Tomillo	2	
	36	8000 59940	Anello di arresto	Snap ring	Bague arrêt	Haltering	Anillo elástico de retención	4	
	37	1617955-01	Bussola	Bushing	Douille	Buchse	Manguito	1	
	38	8000 53339	Anello di tenuta	Seal ring	Bague étanchéité	Dichtungsring	Anillo de retención	1	
	39	60110 7335	Vite	Screw	Vis	Schraube	Tomillo	2	
	40	60110 2511	Vite	Screw	Vis	Schraube	Tomillo	5	
★	41	8000 78116	Assieme motore	Engine assy	Moteur complet	Motor kpl.	Motor compl.	1	
☆	41	8000 78381	Assieme motore	Engine assy	Moteur complet	Motor kpl.	Motor compl.	1	
◆	42	8000 70991	Cilindro completo	Cylinder assy	Cylindre compl.	Zylinder kpl.	Cilindro compl.	1	
◆	42	8000 80136	Cilindro completo (ASSO)	Cylinder assy	Cylindre compl.	Zylinder kpl.	Cilindro compl.	1	
	43	8000 53644	Guarnizione	Gasket	Garniture	Dichtung	Junta	1	
	44	8000 8536	Rosetta piana	Washer	Rondelle	Scheibe	Arandela	2	
	45	8000 66395	Raccordo	Union	Raccord	Anschluss	Empalme	1	
	46	8000 69791	Gruppo guarnizioni motore	Gasket set	Groupe garnitures	Dichtungssatz	Grupo juntas	1	
	47	8000 15160	Rosetta	Washer	Rondelle	Scheibe	Arandela	1	
	48	8000 4319	Piastrina	Plate	Plaque	Plättchen	Placa	1	

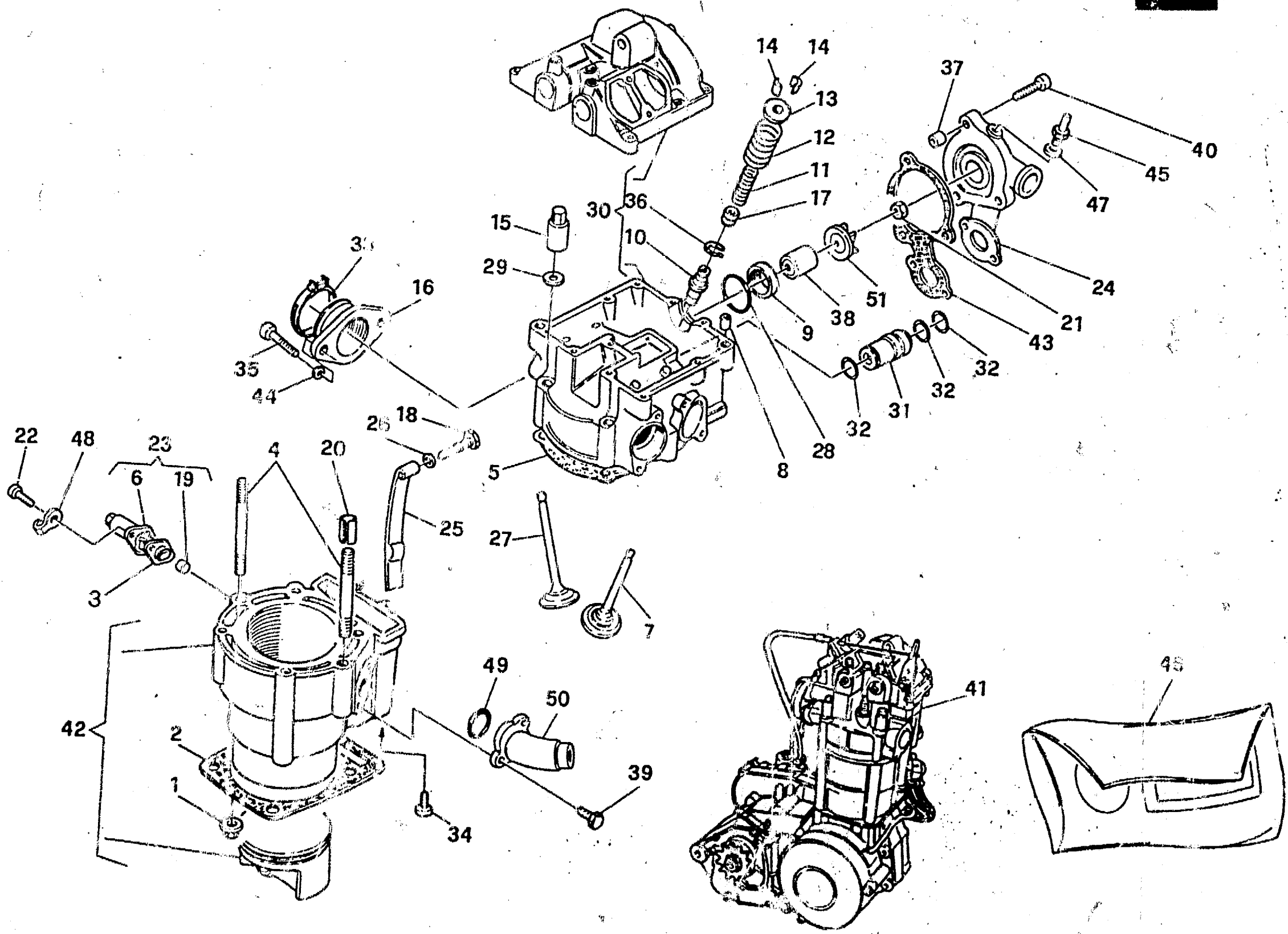



TESTA, CILINDRO - CYLINDER HEAD, CYLINDER
CULASSE, CYLINDRE - ZYLINDERKOPF, ZYLINDER
CULATA, CILINDRO

TAVOLA
DRAWING
TABLE
BILD
TABLA

2

TE - TC
610 / 95

Note Notes Marka Notas	Pos. No. N. Index Pos.	N. Cod. Code No. N. Code Code Nr N. Cod.	DENOMINAZIONE	NAME	DESIGNATION	BESCHREIBUNG	DENOMINACION	Q.ty Qty M.ge C.st	Valida Validity Valable Gültig Válidaz
	49	8000 19789	Anello OR	O-Ring	Bague OR	O-Ring	Anillo OR	1	
	50	80A0 66222	Raccordo	Union	Raccord	Anschluss	Empalme	1	
	51	8A00 60415	Girante	Rotor	Couronne	Laufrad	Rotor	1	
			★ = Modello TE ☆ = Modello TC ◆ = In alternativa ○ = Fornire in coppia	★ = TE model ☆ = TC model ◆ = In alternative ○ = Supply unitely	★ = Modèle TE ☆ = Modèle TC ◆ = En alternative ○ = Fournir ensemble	★ = Model TE ☆ = Model TC ◆ = Die Auswahl ○ = Wird zusammen geliefert	★ = Modelo TE ☆ = Modelo TC ◆ = En alternativa ○ = Equipar juntos		

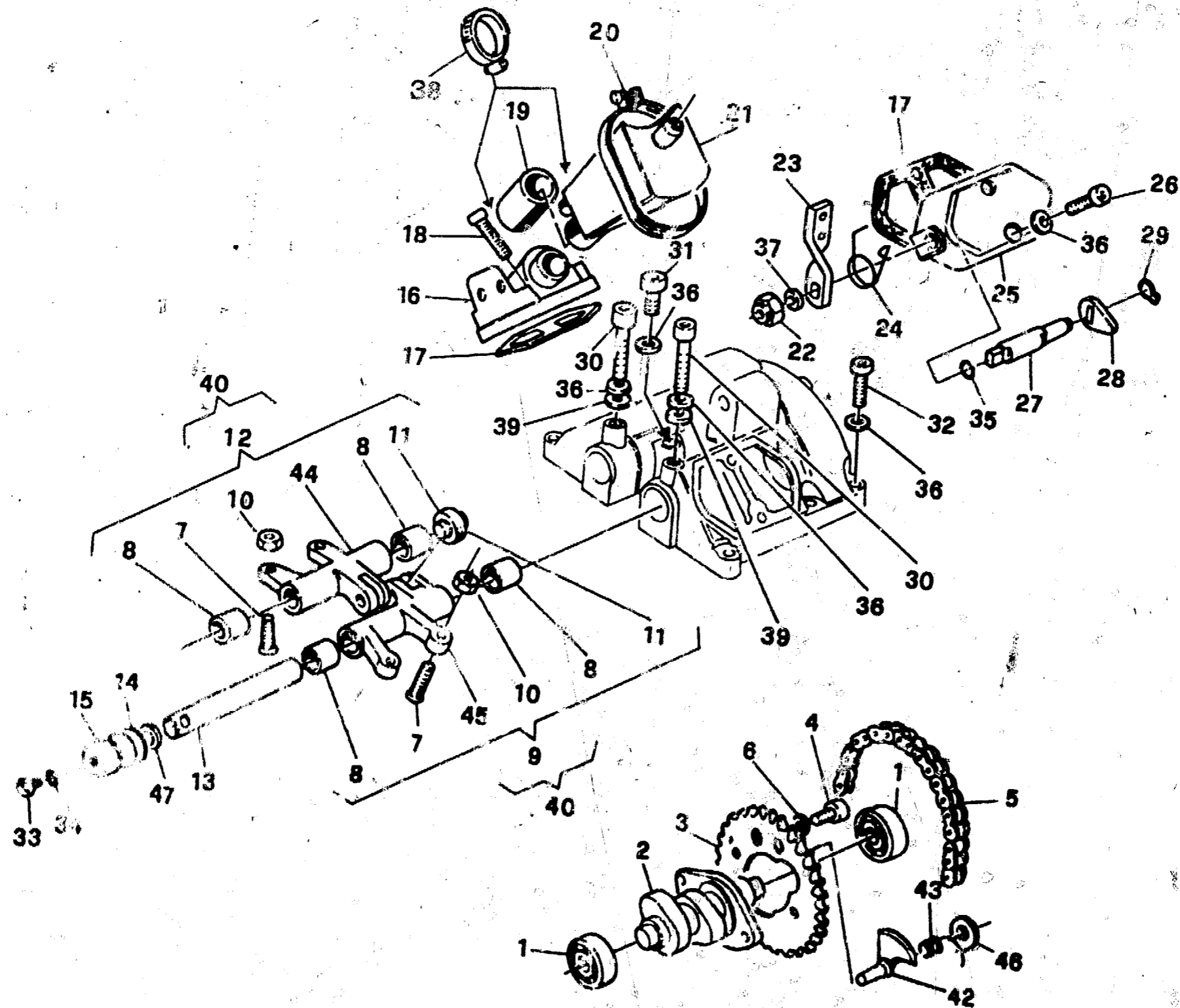



DISTRIBUZIONE - VALVE TIMING
DISTRIBUTION - VENTILSTEUERUNG
DISTRIBUCION

TAVOLA
DRAWING
TABLE
BILD
TABLA

3

TE - TC
610 / 95

Note Notes Notas	Pos. No. Indice Pos.	N. Cod. Code No. Nr. Code Code Nr N. Cod.	DENOMINAZIONE	NAME	DESIGNATION	BESCHREIBUNG	DENOMINACION	Q.tà Qty Menge Cant	Validità Validity Gültig Validez
	1	80000 2124	Cuscinetto	Bearing	Roulement	Lager	Cojinete	2	
★	2	8000 73150	Albero a camme	Camshaft	Arbre distribution	Nockenwelle	Eje distribución	1	
☆	2	8000 75780	Albero a camme	Camshaft	Arbre distribution	Nockenwelle	Eje distribución	1	
	3	8000 71028	Ingranaggio condotto	Driven gear	Engrainage conduit	Zahnrad	Engranaje conducido	1	
	4	1615266-02	Vite	Screw	Vis	Schraube	Tornillo	2	
	5	8A00 35794	Catena distribuzione	Chain	Chaîne	Kette	Cadena	1	
	6	62N1 15658	Rosetta elastica	Spring washer	Rondelle élastique	Federscheibe	Arandela elástica	2	
	7	1615049-01	Vite di registro	Adjusting screw	Vis de réglage	Verstellungsschraube	Tornillo de regulación	4	
	8	1615043-01	Bussola	Bushing	Douille	Buchse	Manguito	4	
	9	1615096-01	Bilancere di scarico completo	Exhaust rocker-arm assy	Culbuteur échappement compl.	Kipphebel Auspuffrohr kpl.	Balancín de escape compl.	1	
	10	1615156-01	Dado	Nut	Ecrou	Mutter	Tuerca	4	
	11	1615045-01	Cuscinetto a rullini	Needle bearing	Roulement à aiguilles	Nadelkäfig	Cojinete de rodillos	2	
	12	1615095-01	Bilancere di aspirazione compl.	Inlet rocker-arm assy	Culbuteur d'aspiration compl.	Kipphebel Ansaugen kpl.	Balancín de aspiración compl.	1	
	13	1615042-01	Perno	Pin	Pivot	Bolzen	Perno	2	
	14	8000 59939	Anello OR	O-Ring	Bague OR	O-Ring	Anillo OR	2	
	15	1615393-01	Tappo	Plug	Bouchon	Verschluss	Tapón	2	
◆	16	1615121-03	Coperchio registri	Cover	Couvercle	Deckel	Tapa	1	
◆	16	8080 84174	Coperchio registri	Cover	Couvercle	Deckel	Tapa	1	
	17	1615036-01	Guarnizione	Gasket	Garniture	Dichtung	Junta	2	
	18	60N10 7336	Vite	Screw	Vis	Schraube	Tornillo	3	
	19	1615141-03	Tubetto	Tube	Tuyau	Rohr	Tubo	1	
	20	8000 37299	Fascetta	Clamp	Collier	Schelle	Banda	1	
	21	1615128-02	Contenitore vapori basamento	Crankcase vapours cup	Cuve vapeurs carter	Dampfgefäß im Kurbelgehäuse	Contenedor vapores cárter	1	
	22	61N1 15195	Dado	Nut	Ecrou	Mutter	Tuerca	1	
	23	1615408-01	Leva	Lever	Levier	Hebel	Palanca	1	
	24	1615123-01	Molla	Spring	Ressort	Feder	Resorte	1	

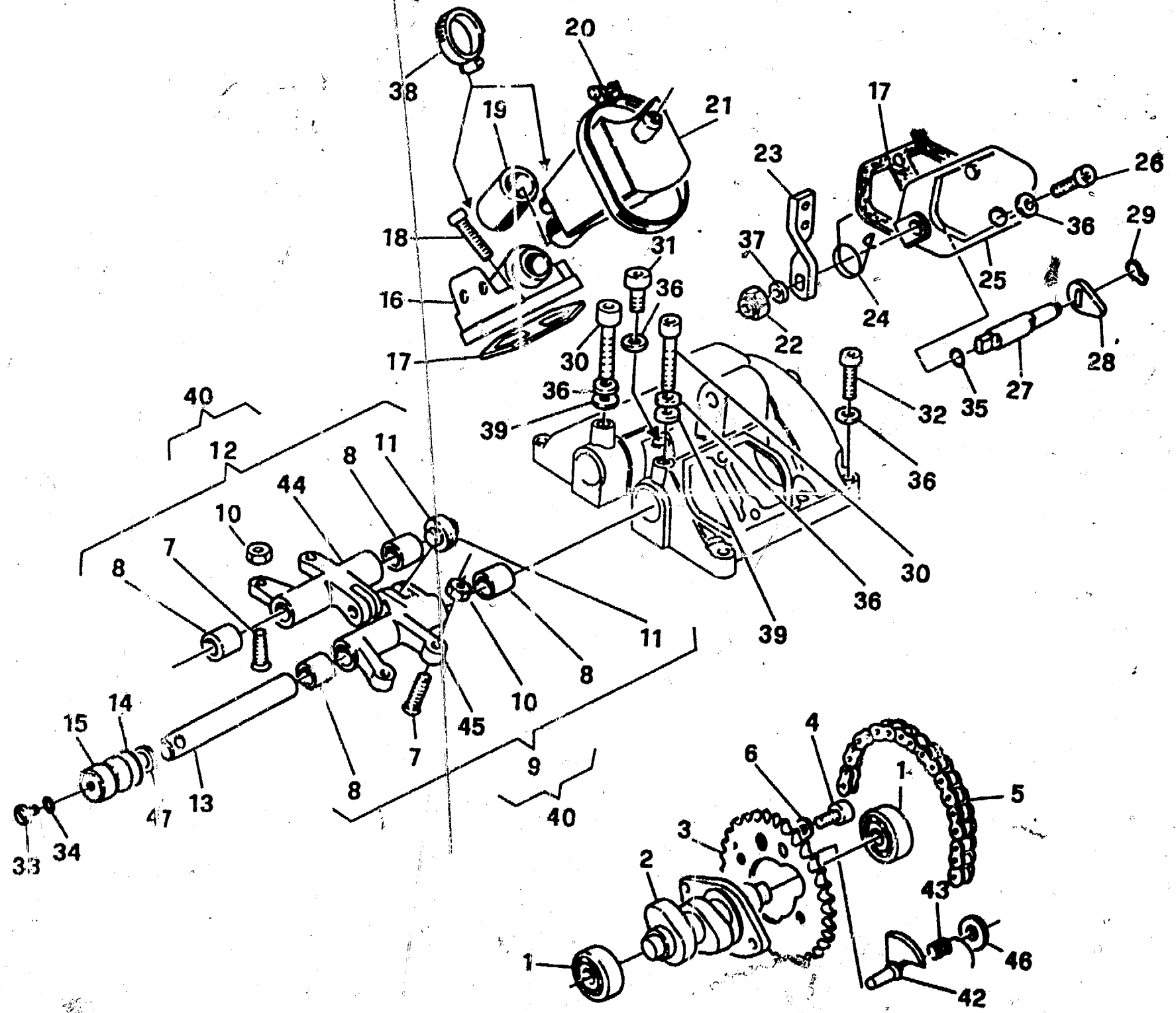



DISTRIBUZIONE - VALVE TIMING
DISTRIBUTION - VENTILSTEUERUNG
DISTRIBUCION

TAVOLA
DRAWING
TABLE
BILD
TABLA

3

TE - TC
610 / 95

Note Notes Notas	Pos. No. Index Pos.	N. Cod. Code No. Nr. Code Code Nr N. Cod.	DENOMINAZIONE	NAME	DESIGNATION	BESCHREIBUNG	DENOMINACION	Q.tà Qty M. qd C. m	Validità Validity Validés Gültig Validez
◆	25	1615035-02	Coperchio decompressore	Cover	Couvercle	Deckel	Tapa	1	
◆	25	80B0 84173	Coperchio decompressore	Cover	Couvercle	Deckel	Tapa	1	
	26	60N10 2513	Vite	Screw	Vis	Schraube	Tomillo	1	
	27	1615084-01	Perno	Pin	Pivot	Bolzen	Perno	1	
	28	1615085-01	Camma decompressore	Cam	Came	Nocken	Excéntrico	1	
	29	8000 21375	Anello di fermo	Stop ring	Bague d'arrêt	Haltering	Anillo de retención	1	
	30	60N10 2517	Vite	Screw	Vis	Schraube	Tomillo	2	
	31	60N10 2514	Vite	Screw	Vis	Schraube	Tomillo	1	
	32	60N10 2511	Vite	Screw	Vis	Schraube	Tomillo	8	
	33	60N10 2927	Vite	Screw	Vis	Schraube	Tomillo	2	
	34	8A00 15960	Rosetta piana	Washer	Rondelle	Scheibe	Arandela	2	
	35	8000 59941	Anello OR	O-Ring	Bague OR	O-Ring	Anillo OR	1	
	36	62N1 15504	Rosetta piana	Washer	Rondelle	Scheibe	Arandela	13	
	37	62N1 15567	Rosetta piana	Washer	Rondelle	Scheibe	Arandela	1	
	38	8000 46881	Fascetta	Clamp	Collier	Schelle	Banda	2	
	39	8000 64988	Rosetta	Washer	Rondelle	Scheibe	Arandela	2	
	40	1619854-01	Ass. coppia bilanceri	Rocker-arm pair assy	Couple culbuteur compl.	Kipphebelpaar kpl.	Pareja balancín compl.	1	
	42	8000 72289	Alzavalvola	Valve lifter	Levée de soupape	Ventilauheber	Alza valvula	1	
	43	8000 72290	Molla	Spring	Ressort	Feder	Resorte	1	
	46	8F00 10789	Rosetta	Washer	Rondelle	Scheibe	Arandela	1	
	47	8000 50322	Rosetta di rasamento Sp. 0,3	Washer	Rondelle	Scheibe	Arandela	2	
	47	8A00 50322	Rosetta di rasamento Sp. 0,4	Washer	Rondelle	Scheibe	Arandela	2	
	47	8B00 50322	Rosetta di rasamento Sp. 0,5	Washer	Rondelle	Scheibe	Arandela	2	
	47	8C00 50322	Rosetta di rasamento Sp. 0,6	Washer	Rondelle	Scheibe	Arandela	2	

★ = Modello TE
 ☆ = Modello TC
 ◆ = In alternativa

★ = TE model
 ☆ = TC model
 ◆ = In alternative

★ = Modèle TE
 ☆ = Modèle TC
 ◆ = En alternative

★ = Modell TE
 ☆ = Modell TC
 ◆ = Die Auswahl

★ = Modelo TE
 ☆ = Modelo TC
 ◆ = En alternativa

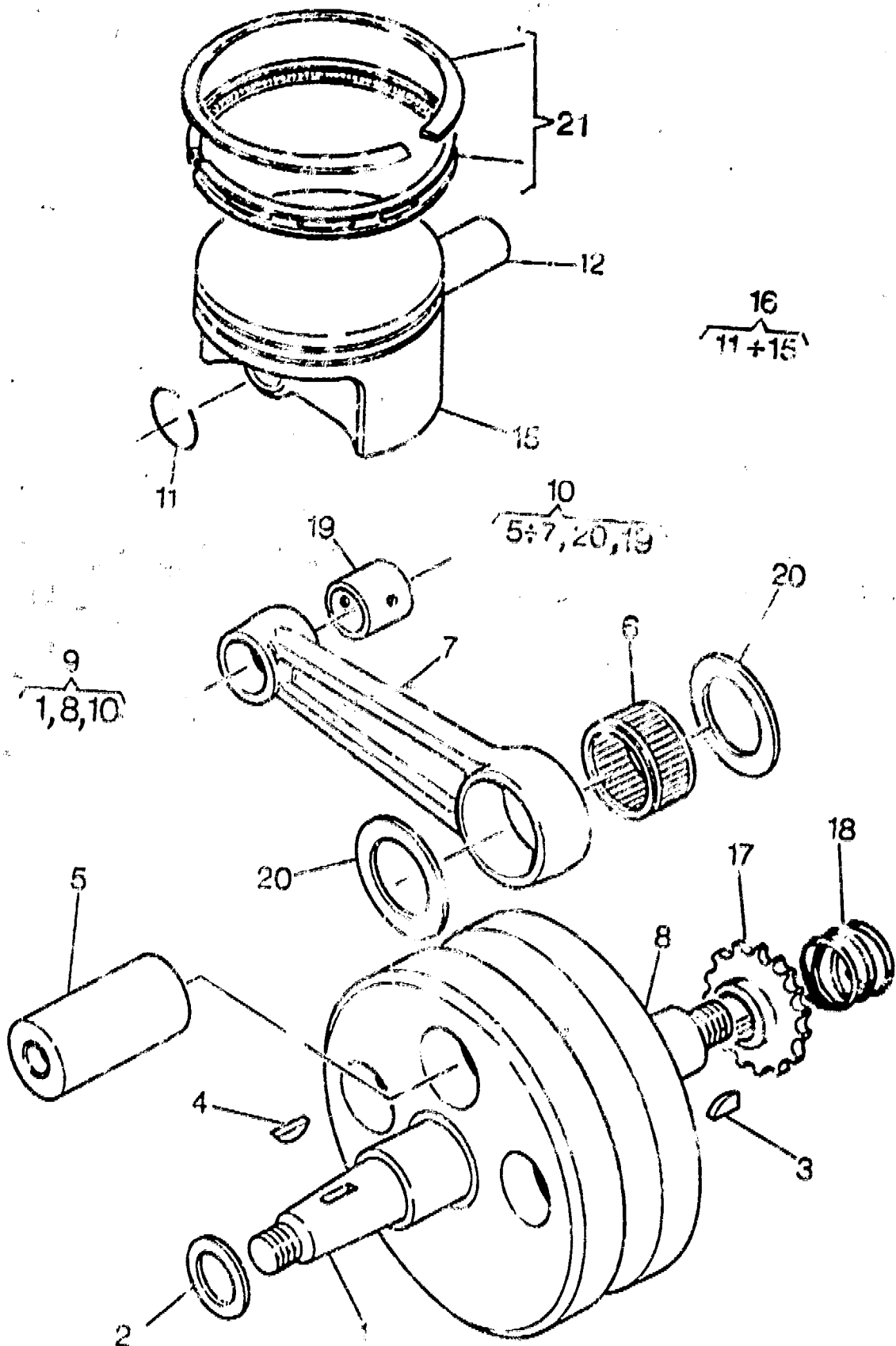



**PISTONE, MANOVELLISMO - PISTON, CRANKSHAFT
PISTON, VILEBREQUIN - KOLBEN, KURBELWELLE
PISTON, PALANCAS**

**TAVOLA
DRAWING
TABLE
BILD
TABLA**

**TE - TC
610 / 95**

N. de Pos. Notes Marka Notas	Pos. No. N. Index Pos.	N. Cod. Code No. Nr. Code Code Nr N. Cod.	DENOMINAZIONE	NAME	DESIGNATION	BESCHREIBUNG	DENOMINACION	QTY C.M	Value Value Value Value Value
	2	8A00 28183	Rosetta di rasamento Sp. 0,3	Washer	Rondelle	Scheibe	Arandela	1	
	2	8C00 28183	Rosetta di rasamento Sp. 0,5	Washer	Rondelle	Scheibe	Arandela	1	
	2	8D00 28183	Rosetta di rasamento Sp. 0,6	Washer	Rondelle	Scheibe	Arandela	1	
	2	8F00 28183	Rosetta di rasamento Sp. 0,8	Washer	Rondelle	Scheibe	Arandela	1	
	2	9H00 28183	Rosetta di rasamento Sp. 1,5	Washer	Rondelle	Scheibe	Arandela	1	
	3	1615098-01	Linguetta	Woodruff key	Clé woodruff	Federkeil	Lingüeta	1	
	4	1513713-01	Linguetta	Woodruff key	Clé woodruff	Federkeil	Lingüeta	1	
	9	8000 67735	Albero motore completo	Crankshaft assy	Vilebrequin compl.	Kurbewelle kpl.	Cigüeñal compl.	1	
	10	8000 67825	Biella completa	Connecting rod compl.	Bielle compl.	Pleuerstange kpl.	Biela motor completa	1	
	11	8000 67824	Anello di fermo	Stop ring	Bague d'arrêt	Haltring	Anillo de retención	2	
	12	8000 71787	Spinotto	Gudgeon	Axe	Bolzen	Perno	1	
◆	16	8000 70993	Pistone completo Ø 98	Compl. piston	Piston complet	Kolbe, kpl.	Pistón completo	1	
◆	16	8000 80535	Pistone completo Ø 98 (ASSO)	Compl. piston	Piston complet	Kolbe, kpl.	Pistón completo	1	
	17	8B00 71027	Ingranaggio distribuzione	Gear	Engrenage	Zahnrad	Engranaje	1	
	18	8000 61275	Molla	Spring	Ressort	Feder	Resorte	1	
	19	8000 67740	Bussola (CON FORI)	Bushing (WITH HOLES)	Douille (AVEC TROU)	Buchse (MIT LOCH)	Manguito (CON ORIFICIOS)	1	
	19	8A00 67740	Bussola (SENZA FORI)	Bushing (WITHOUT HOLES)	Douille (SANS TROU)	Buchse (OHNE LOCH)	Manguito (SIN ORIFICIOS)	1	
	20	8000 59540	Rosetta di rasamento	Washer	Rondelle	Scheibe	Arandela	2	
	21	8000 77715	Kit segmenti	Circlip kit	Kit segment	Kolbenring kit	Kit segmento	1	
			◆ = In alternativa	◆ = In alternative	◆ = En alternative	◆ = Die Auswahl	◆ = En alternativa		

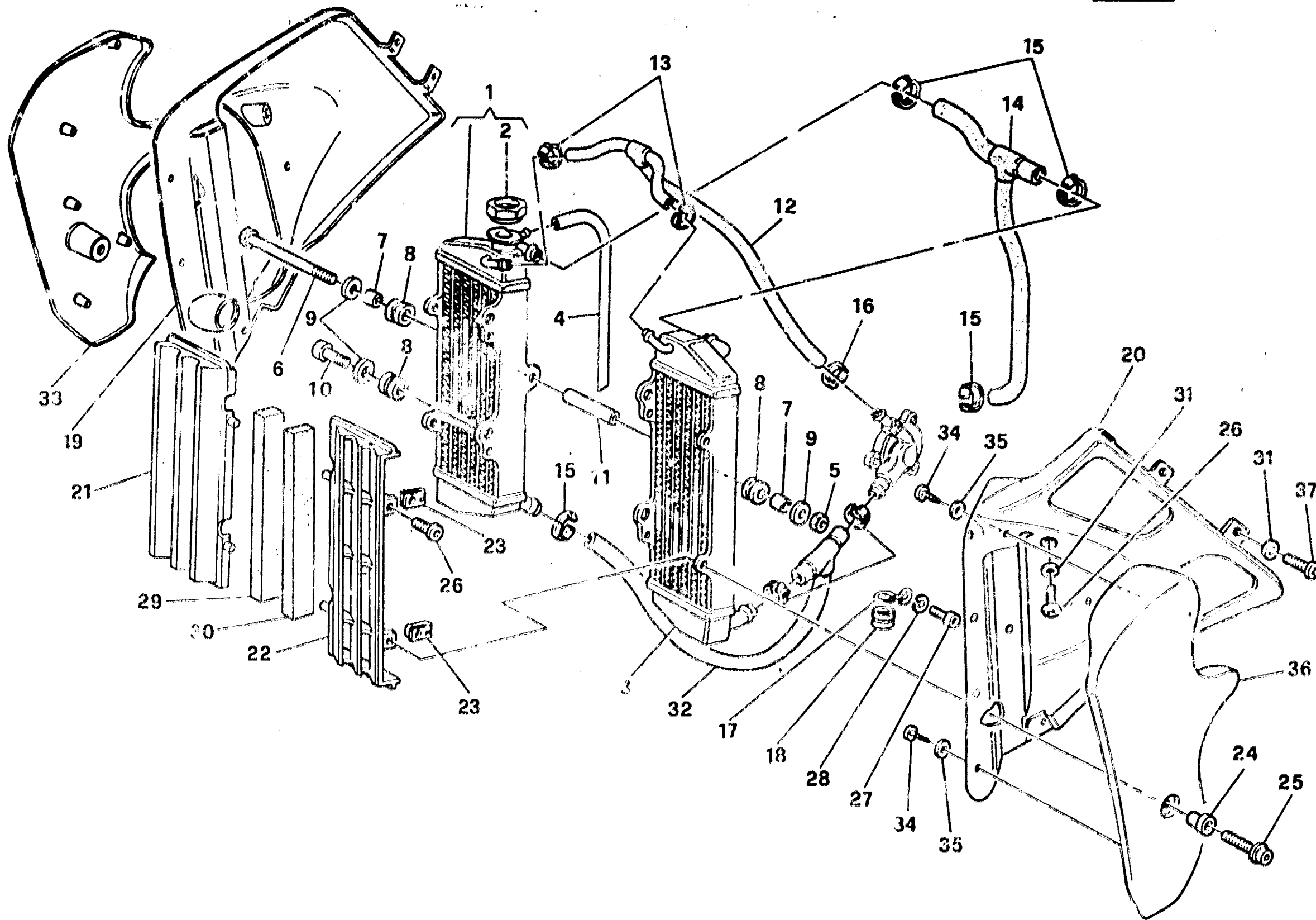



RAFFREDDAMENTO - COOLING
REFROIDISSEMENT - WASSERKÜHLUNG
ENFRIAMIENTO

TAVOLA
 DRAWING
 TABLE
 BILD
 TABLA

5

TE - TC
610 / 95

Note Notes Notas	Pos. Pos. Pos.	N. Cod. Code No. Nr. Code Code Nr N. Cod.	DENOMINAZIONE	NAME	DESIGNATION	BESCHREIBUNG	DENOMINACION	Q.tà Qty Cant	Valore Value Value
	1	80A0 67186	Radiatore Dx. completo	F.H. radiator compl.	Radiateur D. compl.	R., Kühler kpl.	Radiador derech. compl.	1	
	2	8000 43714	Tappo	Plug	Bouchon	Verschluss	Tapón	1	
	3	80A0 66800	Radiatore Sx.	L.H. radiator	Radiateur G.	L., Kühler	Radiador izrdo.	1	
	4	8000 43715	Tubetto sfiato	Tube	Tuyau	Rohr	Tubo	1	
	5	8000 44240	Dado	Nut	Ecrou	Mutter	Tuerca	1	
	6	60N10 2525	Vite	Screw	Vis	Schraube	Tomillo	1	
	7	8000 59802	Bussola	Bushing	Douille	Buchse	Manguito	2	
	8	8000 59803	Gommino	Rubber pad	Pièce caoutchouc	Gummistück	Junta de goma	5	
	9	8000 59801	Rosetta piana	Washer	Rondelle	Scheibe	Arandela	5	
	10	8000 62725	Vite	Screw	Vis	Schraube	Tomillo	3	
	11	8000 66858	Distanziale	Spacer	Entretoise	Distanzstück	Separador		
	12	8000 66850	Tubo	Pipe	Tuyau	Schlauch	Tubo	1	
	13	8000 57242	Fascetta	Clamp	Collier	Schelle	Banda	2	
	14	8000 66851	Tubo cilindro radiatori	Pipe	Tuyau	Schlauch	Tubo	1	
	15	8000 68666	Fascetta	Clamp	Collier	Schelle	Banda	6	
	16	8000 27679	Fascetta	Clamp	Collier	Schelle	Banda	1	
	17	8000 68402	Anello di guida	Ring	Bague	Ring	Anillo	1	
	18	8000 67449	Gommino	Rubber pad	Pièce caoutchouc	Gummistück	Junta de goma	1	
	19	8000 79618	Convogliatore Dx	Right side panel	Flanc droit	Rechte Flanke	Lateral derecho	1	
	20	8000 79619	Convogliatore Sx.	Left side panel	Flanc gauche	Linke Flanke	Lateral izquierdo	1	
	21	80A0 67248	Griglia Dx.	R.H. grille	Grille D.	Gitter R.	Parilla der.	1	
	22	80A0 60164	Griglia Sx.	L.H. grille	Grille G.	Gitter L.	Parilla izq.	1	
	23	8000 60873	Dado a graffetta	Nut	Ecrou	Mutter	Tuerca	4	
	24	8000 77627	Boccola	Bush	Douille	Buchse	Casquillo	2	
	25	8000 62727	Vite	Screw	Vis	Schraube	Tomillo	2	
	26	8000 62725	Vite	Screw	Vis	Schraube	Tomillo	10	

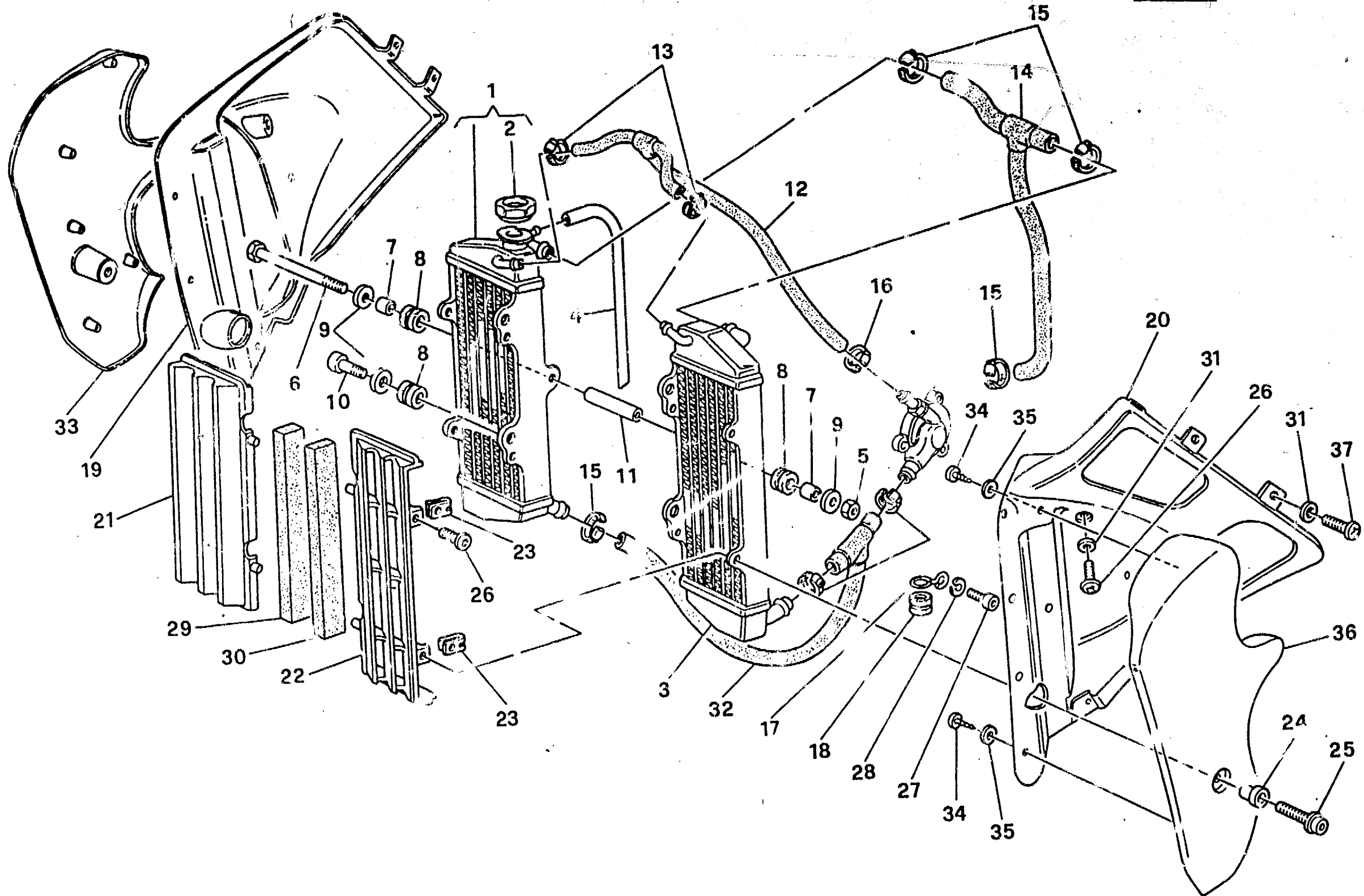



RAFFREDDAMENTO - COOLING
REFROIDISSEMENT - WASSERKÜHLUNG
ENFRIAMIENTO

TAVOLA
DRAWING
TABLE
BILD
TABLA

5

TE - TC
610 / 95

Note Notes Notas	Pos. No. Index Pos.	N. Cod. Code No. Nr. Code Code Nr N. Cod.	DENOMINAZIONE	NAME	DESIGNATION	BESCHREIBUNG	DENOMINACION	Q.tà Qty Q.tà M.pz C.ad	Valori Values Valores
	27	8000 62725	Vite	Screw	Vis	Schraube	Tornillo	1	
	28	62N1 15519	Rosetta piana	Washer	Rondelle	Scheibe	Arandela	1	
	29	8000 60925	Spessore	Spacer	Entretoise	Distanzstück	Separador	1	
	30	8000 60925	Spessore	Spacer	Entretoise	Distanzstück	Separador	1	
	31	8000 45495	Rosetta	Washer	Rondelle	Scheibe	Arandela	8	
	32	8A00 72284	Ass. tubo	Pipe	Tuyau	Schlauch	Tubo	1	
	33	8000 79620	Pannello Dx.	Right side panel	Flanc droit	Rechte Flanke	Lateral derecho	1	
	34	8000 37283	Vite	Screw	Vis	Schraube	Tornillo	10	
	35	62N1 15547	Rosetta	Washer	Rondelle	Scheibe	Arandela	10	
	36	8000 79621	Pannello Sx.	Left side panel	Flanc gauche	Linke Flanke	Lateral izquierdo	1	
	37	8000 36467	Vite	Screw	Vis	Schraube	Tornillo	4	

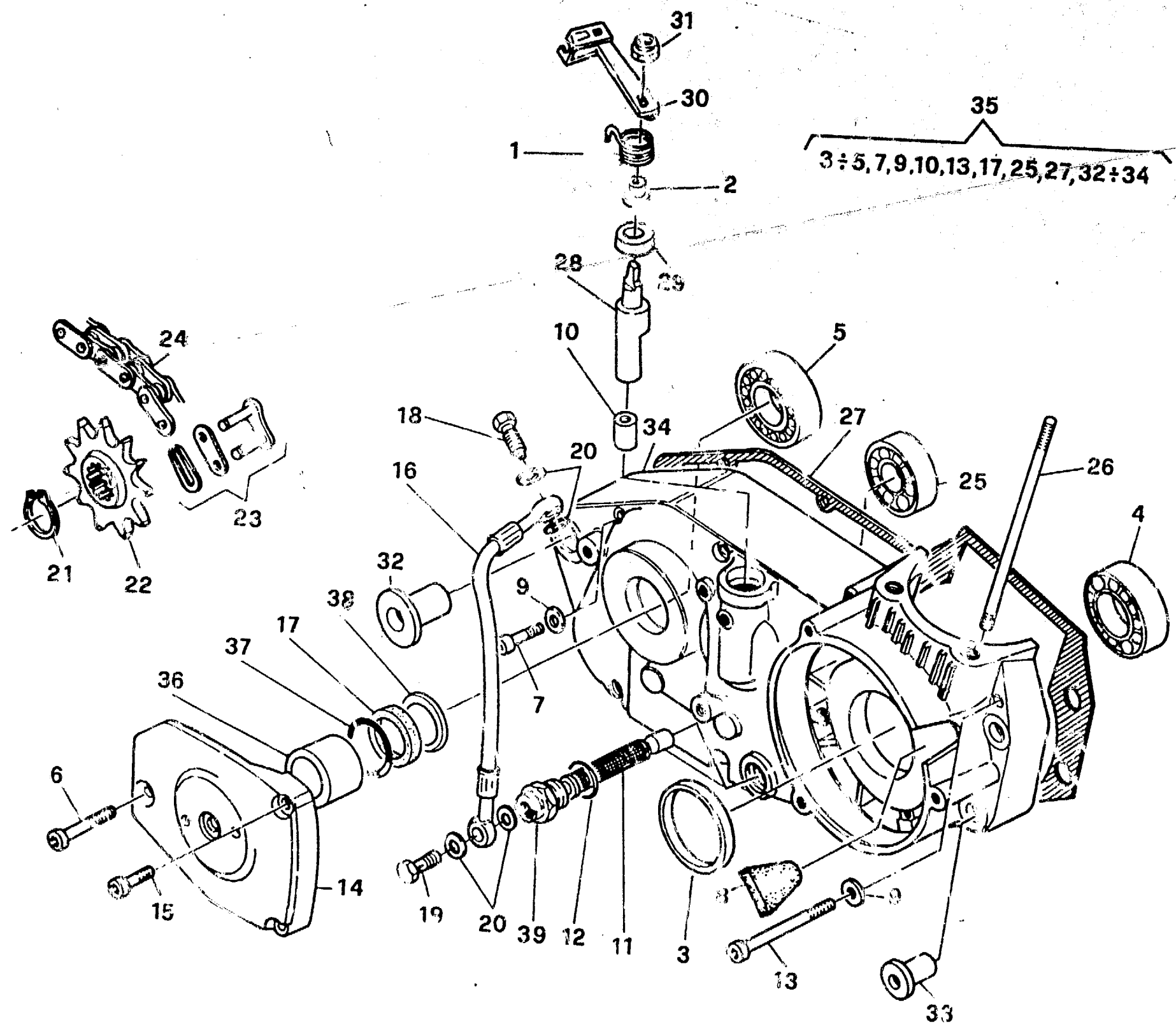



SEMICARTER DESTRO - R.H. HALF CRANKCASE
CARTER D. - GEHAUSEDECKEL R.
BANCADA DER.

TAVOLA
DRAWING
TABLE
BILD
TABLA



TE - TC
610 / 95

Note Notes Notas	Pos. No. N. Index Pos.	N. Cod. Code No. Nr. Code Code Nr N. Cod.	DENOMINAZIONE	NAME	DESIGNATION	BESCHREIBUNG	DENOMINACION	Q.M. Qty Q.tà Menge Cant.	Verf. Vend. Vend. Guth. Vend.
	1	8A00 48188	Molla	Spring	Ressort	Feder	Resorte	1	
	2	8A00 55532	Bussola	Bushing	Douille	Buñse	Manguito	1	
	3	1513726-02	Anello di tenuta	Seal ring	Bague d'étanchéité	Dichtungsring	Anillo de retención	1	
	4	8000 28182	Cuscinetto	Bearing	Roulement	Lager	Cojinete	1	
	5	8000 43789	Cuscinetto	Bearing	Roulement	Lager	Cojinete	1	
	6	60N10 2513	Vite	Screw	Vis	Schraube	Tornillo	1	
	7	60N10 2520	Vite	Screw	Vis	Schraube	Tornillo	6	
	8	1614728-01	Gommino	Rubber pad	Pièce caoutchouc	Gummistück	Junta de goma	1	
	9	62N1 15504	Rosetta piana	Washer	Rondelle	Scheibe	Arandela	8	
	10	8000 68195	Bussola	Bushing	Douille	Buñse	Manguito	1	
	11	8000 75700	Raccordo con magnete	Union	Raccord	Anschluss	Empalme	1	
	12	8000 19609	Guarnizione	Gasket	Garniture	Dichtung	Junta	1	
	13	60N10 2515	Vite	Screw	Vis	Schraube	Tornillo	2	
	14	1611816-04	Coperchio	Cover	Couvercle	Deckel	Tapa	1	
	15	60N10 2510	Vite	Screw	Vis	Schraube	Tornillo	2	
	16	8000 65653	Tubo	Pipe	Tuyau	Schlauch	Tubo	1	
	17	8000 59977	Anello di tenuta	Seal ring	Bague d'étanchéité	Dichtungsring	Anillo de retención	1	
	18	8000 66281	Vite	Screw	Vis	Schraube	Tornillo	1	
	19	8000 45183	Vite	Screw	Vis	Schraube	Tornillo	1	
	20	8000 21487	Rosetta	Washer	Rondelle	Scheibe	Arandela	4	
	21	66N0 21211	Anello di fermo	Stop ring	Bague d'arrêt	Haltering	Anillo de retención	1	
★	22	8000 63832	Pignone Z=17	Pinion	Pignon	Ritzel	Piñón	1	
★	22	8000 63827	Pignone Z=12	Pinion	Pignon	Ritzel	Piñón	1	
★	22	8000 63829	Pignone Z=14 (in dotazione)	Pinion (to issue)	Pignon (en necessaire)	Ritzel (ausrüstungsteile)	Piñón (en dotacion)	1	
◆★	23	8000 65464	Giunto per catena Regina	Coupling	Joint	Kupplung	Junta	1	
◆★	23	8000 79789	Giunto per catena DID	Coupling	Joint	Kupplung	Junta	1	



**SEMICARTER DESTRO - R.H. HALF CRANKCASE
CARTER F. - GEHAUSEDECKEL R.
BANCADA DER.**

TABLA
DRAWING
TABLE
FLD
TABLA

TE-TC
318/95

Note Notes Notas	Pos. No. N. Pos.	N. Cod. Code No. Nr. Code Code Nr. N. Cod.	DENOMINAZIONE	NAME	DESIGNATION	BESCHREIBUNG	DENOMINAZIONE	QTY QTY QTY	Notes Notes Notas
◆☆	23	8000 56767	Giunto per catena Regina	Coupling	Joint	Kupplung	Junta	1	
◆☆	23	8000 79790	Giunto per catena DID	Coupling	Joint	Kupplung	Junta	1	
◆★	24	8A00 65442	Catena con OR Regina	Chain with OR	Chain avec OR	Kette mit OR	Cadena con OR	1	
◆★	24	8C00 79783	Catena con OR DID	Chain with OR	Chain avec OR	Kette mit OR	Cadena con OR	1	
◆☆	24	8B00 56768	Catena Regina	Chain	Chaîne	Kette	Cadena	1	
◆☆	24	8D00 79785	Catena DID	Chain	Chaîne	Kette	Cadena	1	
	25	8000 19768	Cuscinetto	Bearing	Roulement	Lager	Cujinete	1	
	26	1615116-01	Prigioniero cilindro	Stud bolt	Prisonnier	Stiftschraube	Prisionero	4	
	27	1615014-02	Guarnizione	Gasket	Garniture	Dichtung	Junta	1	
	28	8A00 68201	Albero comando frizione	Shaft	Arbre	Weile	Eje	1	
	29	1513722-01	Anello di tenuta	Seal ring	Bague d'étanchéité	Dichtungsring	Anillo de retención	1	
	30	8A00 68196	Leva	Lever	Lévier	Hebel	Palanca	1	
	31	8000 56410	Dado	Nut	Ecrou	Mutter	Tuerca	1	
	32	1614589-01	Bussola	Bushing	Douille	Buchse	Manguito	1	
	33	1610777-01	Bussola	Bushing	Douille	Buchse	Manguito	2	
	35	8A00 69774	Carter motore accoppiati compl.	Crankcase assy	Carter compl.	Kurberlgehäuse kpl.	Carter motor completi	1	
	36	8000 60464	Distanziale	Spacer	Entretoise	Distanzstück	Separador	1	
	37	8000 23110	Anello OR	O-Ring	Bague OR	O-Ring	Anillo OR	1	
	38	8A00 36022	Rosetta di rasamento Sp. 0,2	Washer	Rondelle	Scheibe	Arandela	1	
	38	8B00 36022	Rosetta di rasamento Sp. 0,3	Washer	Rondelle	Scheibe	Arandela	1	
	38	8C00 36022	Rosetta di rasamento Sp. 0,4	Washer	Rondelle	Scheibe	Arandela	1	
	38	8D00 36022	Rosetta di rasamento Sp. 0,5	Washer	Rondelle	Scheibe	Arandela	1	
	39	8000 75704	Raccordo	Union	Raccord	Anschluss	Empalme	1	

★ = Modello TE
☆ = Modello TC
◆ = In alternativa

★ = TE model
☆ = TC model
◆ = In alternative

★ = Modèle TE
☆ = Modèle TC
◆ = En alternative

★ = Modell TE
☆ = Modell TC
◆ = Die Auswahl

★ = Modelo TE
☆ = Modelo TC
◆ = En alternativa

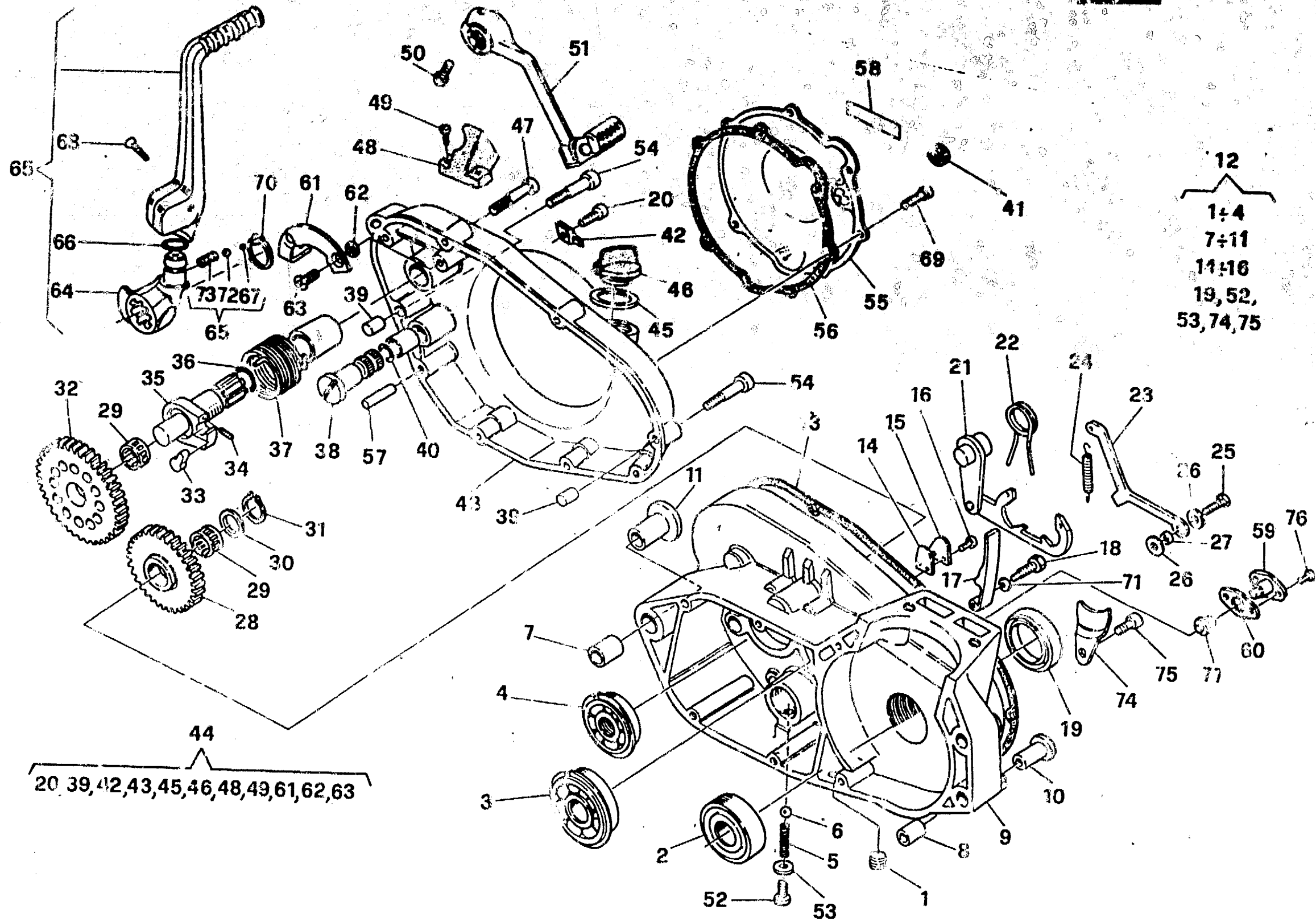

20, 39, 42, 43, 45, 46, 48, 49, 61, 62, 63

12
14
7-11
14-16
19, 52,
53, 74, 75



**SEMICARTER SIN., AVVIAMENTO - L.H. HALF CRANKCASE, STARTING
CARTER G., DEMARRAGE - GEHAUSEDECKEL L., ANLASSER
BANCADA IZQ., ARRANQUE**

**TAVOLA
DRAWING
TABLE
BILD
TABLA**

7

**TE - TC
610 / 95**

Nota Notes Notas No:as	Pos. No. N. Marka index Pos.	N. Cod. Code No. Nr. Code Code Nr. N. Cod.	DENOMINAZIONE	NOME	DESIGNATION	BESCHREIBUNG	DE NOMINACION	Q. M. Q. M. M. g. C. M.	Valida Valida Valida Qualig Valida
	1	8000 69769	Tappo	Plug	Bouchon	Verschluss	Tapón	1	
	2	8000 28182	Cuscinetto	Bearing	Roulement	Lager	Cojinete	1	
	3	8000 59975	Cuscinetto	Bearing	Roulement	Lager	Cojinete	1	
	4	8000 59976	Cuscinetto	Bearing	Roulement	Lager	Cojinete	1	
	5	8000 61263	Molla	Spring	Ressort	Feder	Resorte	1	
	6	8000 60476	Sfera	Ball	Bille	Kugel	Esfera	1	
	7	1614530-01	Bussola di riferimento	Bushing	Douille	Buchse	Manguito	1	
	8	1610776-01	Bussola di riferimento	Bushing	Douille	Buchse	Manguito	1	
	10	1610777-01	Bussola	Bushing	Douille	Buchse	Manguito	1	
	11	1614589-01	Bussola	Bushing	Douille	Buchse	Manguito	1	
	12	8A00 69774	Carter motore accoppiati compl.	Crankcase assy	Carter compl.	Kurbergehäuse kpl.	Carter motor completi	1	
	13	1611650-03	Guarnizione	Gasket	Garnitur	Dichtung	Junta	1	
	14	1615348-01	Vaivola lamellare	Reed valve	Soupape lamellaire	Ventil lamellar	Válvula laminar	1	
	15	1615105-01	Supporto	Support	Support	Halterung	Soporte elástico	1	
	16	60N10 2866	Vite	Screw	Vis	Schraube	Tornillo	2	
	17	8000 60386	Tendicatena distr.	Chain adjuster	Tendeur de chaine	Kettenspanner	Tensor de cadena	1	
	18	1615359-02	Vite	Screw	Vis	Schraube	Tornillo	1	
	19	1513723-02	Anello di tenuta	Seal ring	Bague d'étanchéité	Dichtungsring	Anillo de retención	1	
	20	8000 26970	Vite	Screw	Vis	Schraube	Tornillo	1	
	21	1611686-01	Selettore cambio	Selector	Selecteur	Waehler	Selector com.	1	
	22	1611692-01	Molla	Spring	Ressort	Feder	Resorte	1	
	23	1611683-02	Saltarello	Click	Cliquet	Strumhaken	Saltarelo	1	
	24	1611684-01	Molla	Spring	Ressort	Feder	Resorte	1	
	25	60N10 1079	Vite	Screw	Vis	Schraube	Tornillo	1	
	26	80000 6385	Rosetta piana	Washer	Rondelle	Scheibe	Arandela	2	
	27	1611216-01	Bussola	Bushing	Douille	Buchse	Manguito	1	

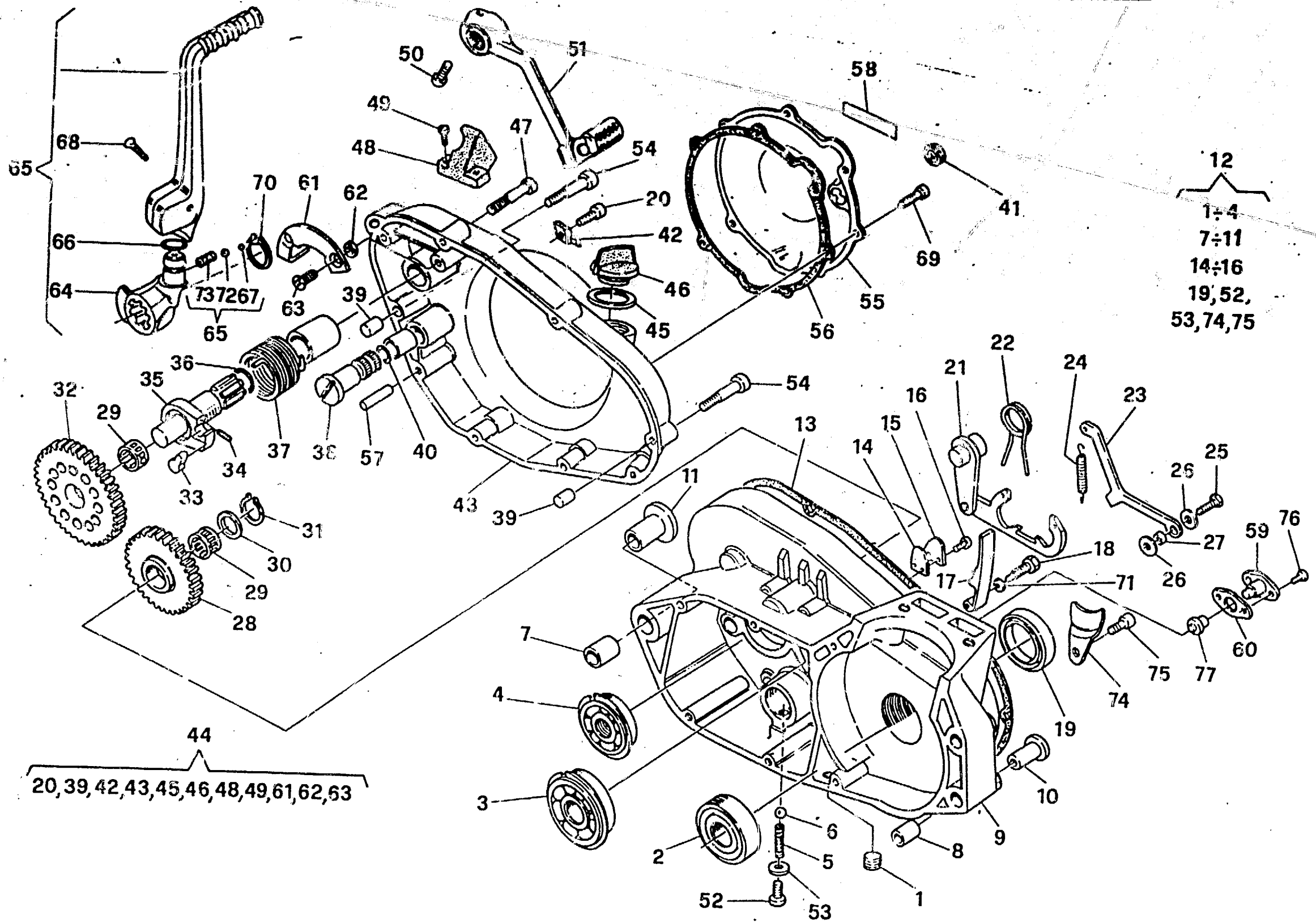



**SEMICARTER STARTING - AVVIAMENTO - L.H. HALF CRANKCASE, STARTING
CARTER G., DÉMARRAGE - GEHAUSEDECKEL L., ANLASSER
BANCADA IZQ., ARRANQUE**

**TAVOLA
DRAWING
TABLE
BILD
TABLA**

**TE - TC
610 / 95**

Note Notes Marka Notas	Pos. No. N. Index Pos.	N. Cod. Code No. Nr. Code Code Nr. N. Cod.	DENOMINAZIONE	NAME	DESIGNATION	BESCHREIBUNG	DENOMINACION	Qty Qty Menge Cant	Value Value Wert Valor
	28	1611271-01	Ingranaggio a rinvio	Gear	Engrainage	Zahnrad	Engranaje	1	
	29	8000 40449	Cuscinetto a rullini	Needle bearing	Roulement à aiguilles	Nadelkäfig	Cojinete de rodillos	2	
	30	8000 38110	Rosetta di rasamento Sp.0,3	Washer	Rondelle	Scheibe	Arandela	1	
	30	8B00 38110	Rosetta di rasamento Sp.0,5	Washer	Rondelle	Scheibe	Arandela	1	
	30	8F00 38110	Rosetta di rasamento Sp.1,0	Washer	Rondelle	Scheibe	Arandela	1	
	31	66N0 21205	Anello di fermo	Stop ring	Bague d'arrêt	Haltering	Anillo de retención	1	
	32	1615391-01	Ingranaggio avviamento	Driven gear	Engrainage conduit	Zahnrad	Engranaje conducto	1	
	33	1611680-01	Saltarello	Click	Cliquet	Strumhaken	Saltarelo	1	
	34	1611681-01	Molla	Spring	Ressort	Feder	Resorte	1	
	35	1611677-02	Albero avviamento	Starter crank shaft	Arbre de démarrage	Kickstarterwelle	Eje arranque	1	
	36	8000 60475	Anello OR	O-Ring	Bague OR	O-Ring	Anillo OR	2	
	37	1616362-01	Molla	Spring	Ressort	Feder	Resorte	1	
	38	1611746-01	Albero pedale cambio	Gearbox pedal shaft	Arbre pédale change de vitesse	Pedal Umsteuerungswelle	Eje pedal cambio	1	
	39	1611708-01	Spina di riferimento	Pin	Goupille	Stift	Clavija	2	
	40	8000 60474	Anello OR	O-Ring	Bague OR	O-Ring	Anillo OR	2	
	41	8000 53340	Oblò	Inspection plug	Capuchon de inspection	Stopfen	Portilla	1	
	42	8000 68710	Gommino	Rubber pad	Pièce caoutchouc	Gummistück	Junta de goma	1	
	44	8A00 75764	Coperchio trasmissione compl.	Cover	Couvercle	Deckel	Tapa	1	
	45	8000 27960	Garnizione	Gasket	Garniture	Dichtung	Junta	1	
	46	8000 36786	Tappo	Plug	Bouchon	Verschluss	Tapón	1	
	47	60N10 2512	Vite	Screw	Vis	Schraube	Tornillo	5	
	48	8000 68584	Tampone ferma pedale	Pad	Tampon	Stopfen	Tampón	1	
	49	60N10 2900	Vite	Screw	Vis	Schraube	Tornillo	2	
	50	60N10 2510	Vite	Screw	Vis	Schraube	Tornillo	1	
	51	8000 69983	Leva cambio compl.	Gearchange lever	Lever comm. vitesse	Schalthebel	Palanca del cambio	1	
	52	8000 66101	Vite	Screw	Vis	Schraube	Tornillo	1	

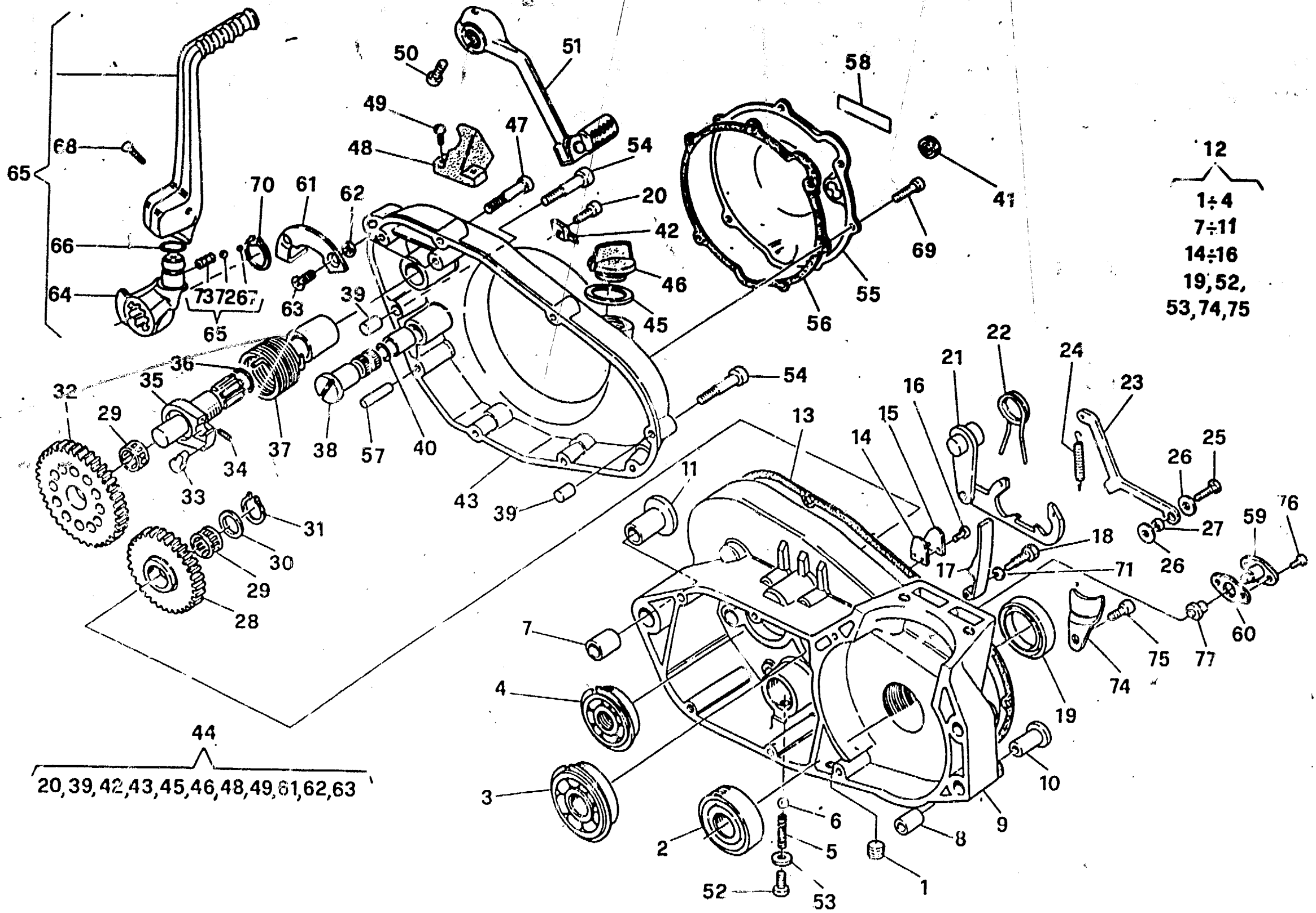

20, 39, 42, 43, 45, 46, 48, 49, 61, 62, 63

12
1-4
7-11
14-16
19, 52,
53, 74, 75



**SEMCARTER SIN., AVVIAMENTO - L.H. HALF CRANKCASE, STARTING
CARTER G., DEMARRAGE - GEHAUSEDECKEL L., ANLASSER
BANCADA IZQ., ARRANQUE**

**TABELA
DRAWING
TABLE
D.S.
TABLA**

**TE-TC
610/95**

Note Notes Notas	Pos. No. N. Pos.	N. Cod. Code No. Fr. Code Code Nr N. Cod.	DENOMINAZIONE	NAME	DESIGNATION	BESCHREIBUNG	DENOMINACION	QTY CANT. CANT.	UNIT VALOR VALOR
	53	8000 47763	Bussola	Bushing	Douille	Buchse	Manguito	1	
	54	60N10 2513	Vite	Screw	Vis	Schraube	Tomillo	2	
	55	8A00 67216	Coperchio	Cover	Couvercle	Deckel	Tapa	1	
	56	8000 68191	Guarnizione	Gasket	Garniture	Dichtung	Junta	1	
	57	8000 60477	Spina di riferimento	Pin	Goupille	Stift	Clavija	1	
	58	8000 79611	Decal. "MAGNESIUM"	"MAGNESIUM" trim	Décal. "MAGNESIUM"	Abziehbild "MAGNESIUM"	Calcomania "MAGNESIUM"	1	
	59	1615377-01	Tappo olio	Oil plug	Bouchon huile	Överschraubung	Tapón aceite	1	
	60	1615378-01	Guarnizione	Gasket	Garniture	Dichtung	Junta	1	
	61	1611704-01	Piastrina fine corsa	Plate	Plaquette	Plättchen	Placa	1	
	62	1611706-01	Distanziale	Spacer	Entretoise	Distanzstück	Separador	2	
	63	8000 60577	Vite	Screw	Vis	Schraube	Tomillo	2	
	64	8000 68174	Mozzetto	Hub	Moyeau	Radnabe	Cubo	1	
	65	8000 69982	Pedale avviamento completo	Pedal	Pedale	Pedal	Pedal	1	
	66	8000 31271	Anello OR	O-Ring	Bague OR	O-Ring	Anillo OR	1	
	67	1611085-01	Tappo	Plug	Bouchon	Verschluss	Tapón	1	
	68	8000 58140	Vite	Screw	Vis	Schraube	Tomillo	1	
	69	60N10 7335	Vite	Screw	Vis	Schraube	Tomillo	6	
	70	66N0 21208	Anello di fermo	Stop ring	Bague d'arrêt	Haltering	Anillo de retención	1	
	71	8000 45194	Rosetta	Washer	Rondelle	Scheibe	Arandela	1	
	72	8000 60472	Sfera	Ball	Bille	Kugel	Esfera	1	
	73	1611084-01	Molla	Spring	Ressort	Feder	Resorte	1	
	74	8000 61269	Piastrina	Plate	Plaquette	Plättchen	Placa	1	
	75	60N10 2504	Vite	Screw	Vis	Schraube	Tomillo	1	
	76	60N10 2898	Vite	Screw	Vis	Schraube	Tomillo	2	
	77	8000 66405	Tappo	Plug	Bouchon	Verschluss	Tapón	1	

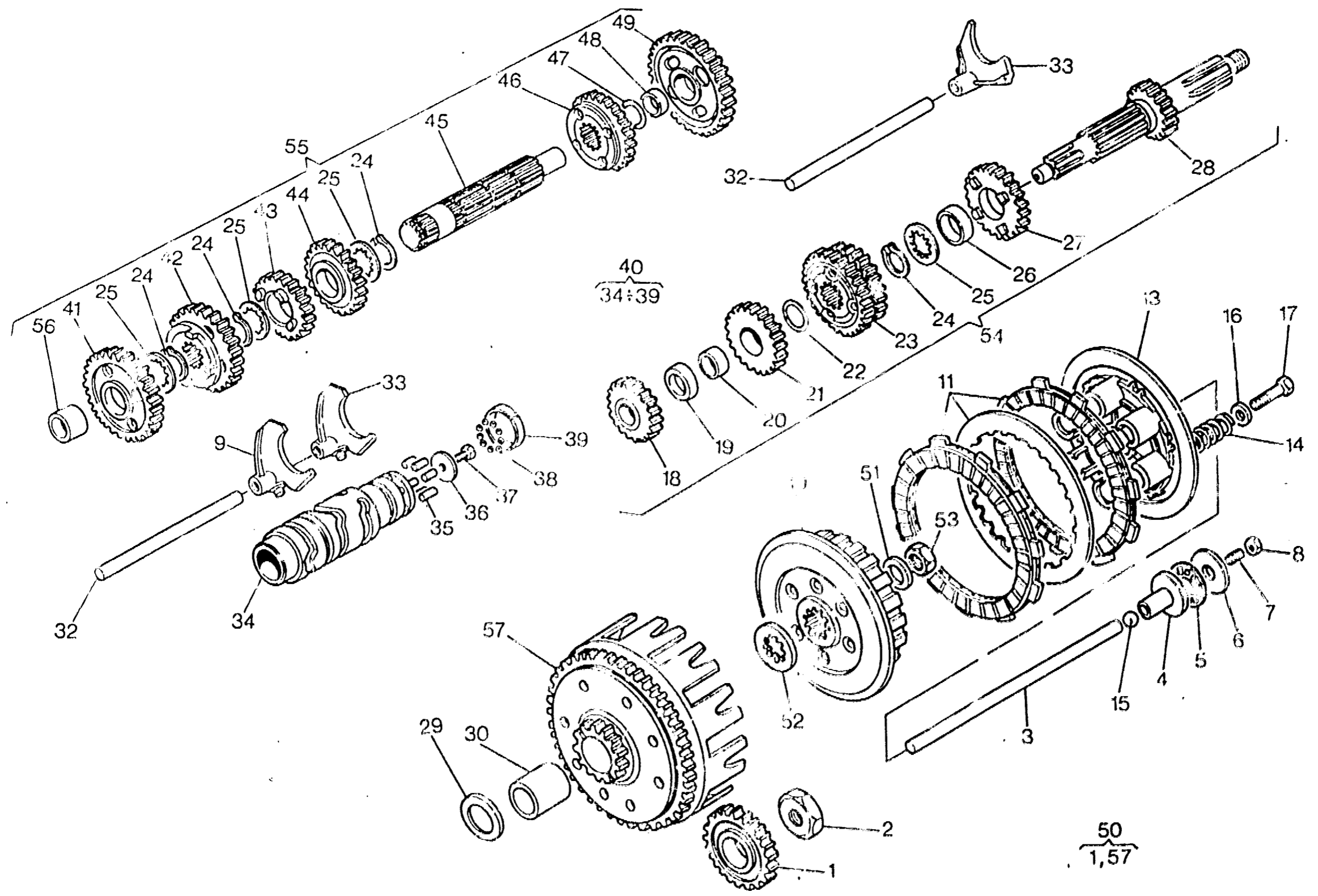



CAMBIO, COMANDO CAMBIO, FRIZIONE - TRANSMISSION, SHIFTER, CLUTCH
BOITE DE VITESSE, COMMANDE DE VITESSE, EMBRAYAGE
WECHSELGETRIEBE, GANGSCHALTUNG, KUPPLUNG - CAMBIO, MANDO CAMBIO, ENBRAGUE

(TE)

TAVOLA
DRAWING
TABLE
BIJL
TABLA



TE - TC
610 / 95

Note Notes Notas	Pos. No. Index Pos.	N. Cod. Code No. Nr. Code Code Nr N. Cod.	DENOMINAZIONE	NAME	DESIGNATION	BESCHREIBUNG	DENOMINACION	Q.tà Qty Cant. M. q. e C. ad.	Validità Validity Validité Gültig Validez
	1	8000 69715	Ingranaggio conduttore	Driving gear	Engrange conducteur	Zahnrad	Engranaje conductor	1	
	2	8000 59965	Dado	Nut	Ecrou	Mutter	Tuerca	1	
	3	1615315-02	Asta di forza	Fork tube	Barre de force	Druckstab	Varilla de fuerza	1	
	4	8000 54477	Piattello	Plate	Plateau	Teller	Placa	1	
	5	8000 35780	Cuscinetto assiale	Bearing	Roulement	Kugellager	Cojinete	1	
	6	8000 35781	Rosetta	Washer	Rondelle	Scheibe	Arandela	1	
	7	8000 54692	Vite	Screw	Vis	Schraube	Tomillo	1	
	8	61N1 15062	Dado	Nut	Ecrou	Mutter	Tuerca	1	
	9	8000 63425	Forcella 3 ^a vel.	Fork	Fourche	Gabel	Horquilla	1	
	10	8A00 43137	Mozzo frizione	Hub	Moyeau	Radnabe	Cubo	1	
	11	8B00 82861	Ass. gruppo frizione	Clutch group assy	Groupe embrayage compl.	Kupplungsgruppe Kpl	Grupo embrague compl.	1	
	13	8000 48138	Piastra spingidischi	Plate	Plaque	Platte	Placa	1	
	14	8000 71230	Molla frizione	Clutch spring	Ressort embrayage	Kupplungsfeder	Resorte embrague	5	
▲	14	8000 42473	Molla frizione	Clutch spring	Ressort embrayage	Kupplungsfeder	Resorte embrague	5	
	15	6BN0 21509	Sfera	Ball	Bille	Kugel	Esfera	1	
	16	8000 21535	Rosetta	Washer	Rondelle	Scheibe	Arandela	5	
	17	60N10 1081	Vite	Screw	Vis	Schraube	Tomillo	5	
	18	1612362-01	Ingranaggio 2 ^a A.P.	Main shaft 2nd gear	Engrenage 2ème vitesse A.P.	Zahn. f. 2. Geschw. Antriebsw.	Engranaje 2º velocidad Eje P.	1	
	19	1612481-01	Distanziale	Spacer	Entretoise	Distanzstück	Separador	1	
	20	1612480-01	Bussola	Bushing	Douille	Buchse	Manguito	1	
	21	1612363-01	Ingranaggio 3 ^a A.P.	Main shaft 3rd gear	Engrenage 3ème vitesse A.P.	Zahn. f. 3. Geschw. Antriebsw.	Engranaje 3º velocidad Eje P.	1	
	22	1612842-01	Rosetta	Washer	Rondelle	Scheibe	Arandela	1	
	23	1612390-01	Ingran. 5 ^a e 6 ^a A.P.	Gear 5th - 6th speed	Engrenage 5ème 6ème	Zahnrad 5. - 6. Gang	Engranaje 5º - 6º velocidad	1	
	24	66N0 21211	Anello di fermo	Stop ring	Bague d'arrêt	Haltering	Anillo de retención	4	
	25	1611717-01	Rosetta	Washer	Rondelle	Scheibe	Arandela	4	
	26	8000 63821	Bussola	Bushing	Douille	Buchse	Manguito	1	

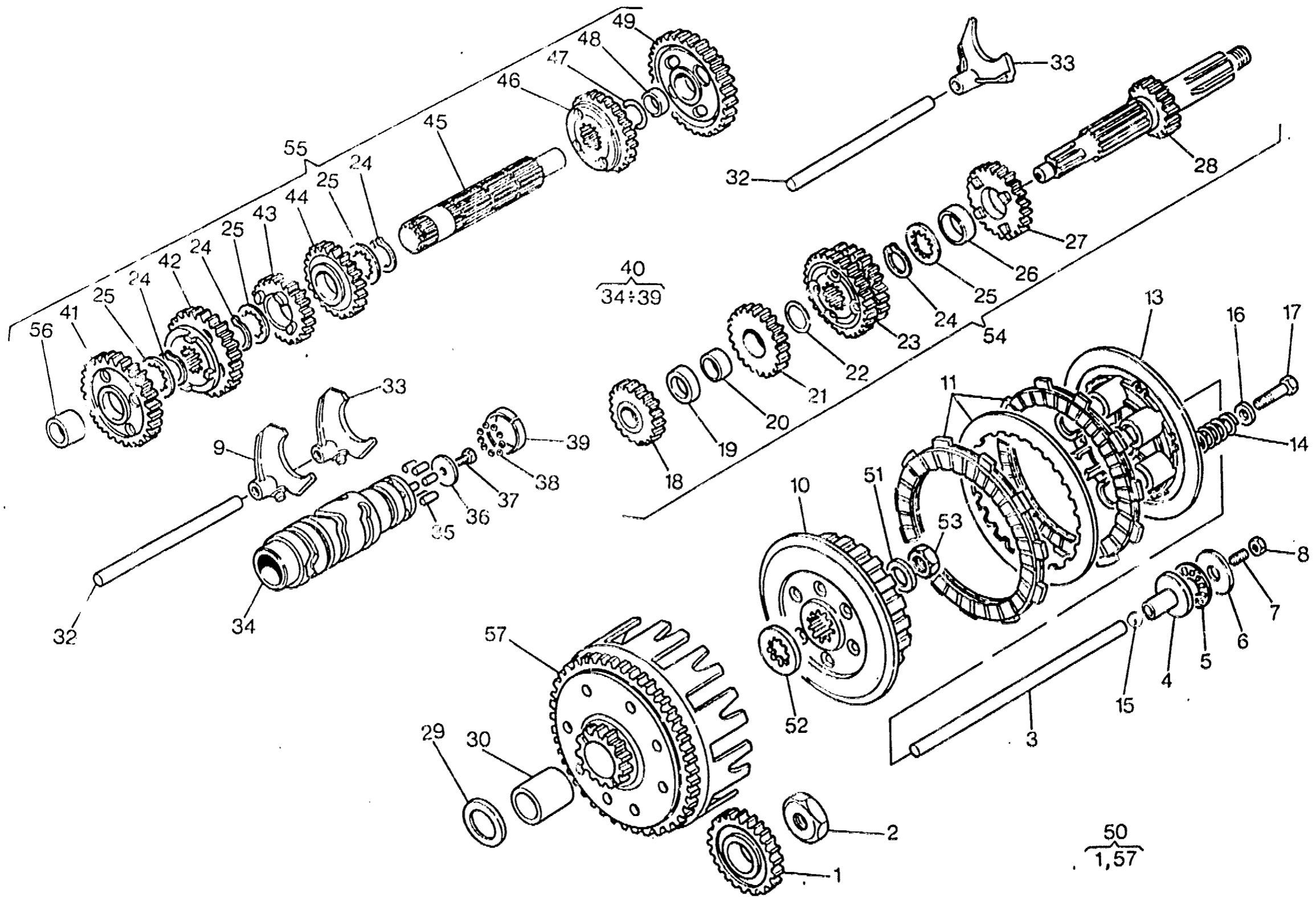



CAMBIO, COMANDO CAMBIO, FRIZIONE - TRANSMISSION, SHIFTER, CLUTCH
BOITE DE VITESSE, COMMANDE DE VITESSE, EMBRAYAGE
WECHSELGETRIEBE, GANGSCHALTUNG, KUPPLUNG - CAMBIO, MANDO CAMBIO, ENBRAGUE

(TE)

TAVOLA
DRAWING
TABLE
BILD
TABLA

8

TE - TC
610 / 95

Note Notes Marka Notas	Pos. No. Index Pos.	N. Cod. Code No. Nr. Code Code Nr N. Cod.	DENOMINAZIONE	NAME	DESIGNATION	BESCHREIBUNG	DENOMINACION	Q.tà Q.ty Q.te M.ge C.ad	Validità Validity Validité Gültig Validez
	27	1611837-01	Ingranaggio 4 ^a A.P.	Main shaft 4th gear	Engrenage 4ème vitesse A.P.	Zahn. f. 4. Geschw. Antriebsw.	Engranaje 4° velocidad Eje P.	1	
	28	8000 69736	Albero primario	Main shaft	Arbre primaire	Hauptwelle	Eje primario	1	
	29	8E00 30053	Rosetta di rasamento	Washer	Rondelle	Scheibe	Arandela	1	
	30	1615388-01	Bussola	Bushing	Douille	Buchse	Manguito	1	
	32	1611699-01	Perno	Pin	Pivot	Bolzen	Perno	2	
	33	1612384-01	Forcella cambio	Fork	Fourche	Gabel	Horquilla	2	
	35	8000 35823	Rullino	Roller	Aiguille	Nelle	Rodillo	6	
	36	8000 30326	Rosetta	Washer	Rondelle	Scheibe	Arandela	1	
	37	8000 60473	Vite	Screw	Vis	Schraube	Tornillo	1	
	38	8000 60472	Sfera	Ball	Bille	Kugel	Esfera	11	
	39	1612699-01	Anello esterno	Ring	Bague	Ring	Anillo	1	
	40	1611701-01	Albero forcelle cambio compl.	Driving shaft gearbox forks	Arbre comm. fourches trans.	Antriebswelle Schaltgabel	Eje mando horquilla cambio	1	
	41	1612365-02	Ingranaggio 2 ^a A.S.	Secondary shaft 2nd gear	Engrenage 2ème vitesse A.S.	Zah. f. 2. Geschw. Vorgelegew.	Engranaje 2° velocidad Eje S.	1	
	42	8000 63424	Ingranaggio 3 ^a A.S.	Secondary shaft 3rd gear	Engrenage 3ème vitesse A.S.	Zah. f. 3. Geschw. Vorgelegew.	Engranaje 3° velocidad Eje S.	1	
	43	1612357-01	Ingranaggio 6 ^a A.S.	Secondary shaft 6th gear	Engrenage 6ème vitesse A.S.	Zah. f. 6. Geschw. Vorgelegew.	Engranaje 6° velocidad Eje S.	1	
	44	1611715-01	Ingranaggio 5 ^a A.S.	Secondary shaft 5th gear	Engrenage 5ème vitesse A.S.	Zah. f. 5. Geschw. Vorgelegew.	Engranaje 5° velocidad Eje S.	1	
	45	8000 60463	Albero secondario	Layshaft	Arbre secondaire	Vorgelegewelle	Eje secundario	1	
	46	1612388-01	Ingranaggio 4 ^a A.S.	Secondary shaft 4th gear	Engrenage 4ème vitesse A.S.	Zah. f. 4. Geschw. Vorgelegew.	Engranaje 4° velocidad Eje S.	1	
	47	1513714-01	Rosetta	Washer	Rondelle	Scheibe	Arandela	1	
	48	1612415-01	Bussola	Bushing	Douille	Buchse	Manguito	1	
	49	1612361-01	Ingranaggio 1 ^a A.S.	Gear 1st speed	Engrenage 1ère	Zahnrad 1. Gang	Engranaje 1° velocidad	1	
	50	8000 69729	Coppia ingran. trasm. primaria	Set of matched primary	Engrenages trans. prim.	Stirnradpaar	Copla engranaje trans. primaria	1	
	51	8000 36857	Rosetta di sicurezza	Washer	Rondelle	Scheibe	Arandela	1	
	52	8A00 38350	Rosetta	Washer	Rondelle	Scheibe	Arandela	1	
	53	8000 36856	Dado	Nut	Ecrou	Mutter	Tuerca	1	
	54	8000 69737	Albero primario completo	Main shaft	Arbre primaire	Hauptwelle	Eje principal completo	1	

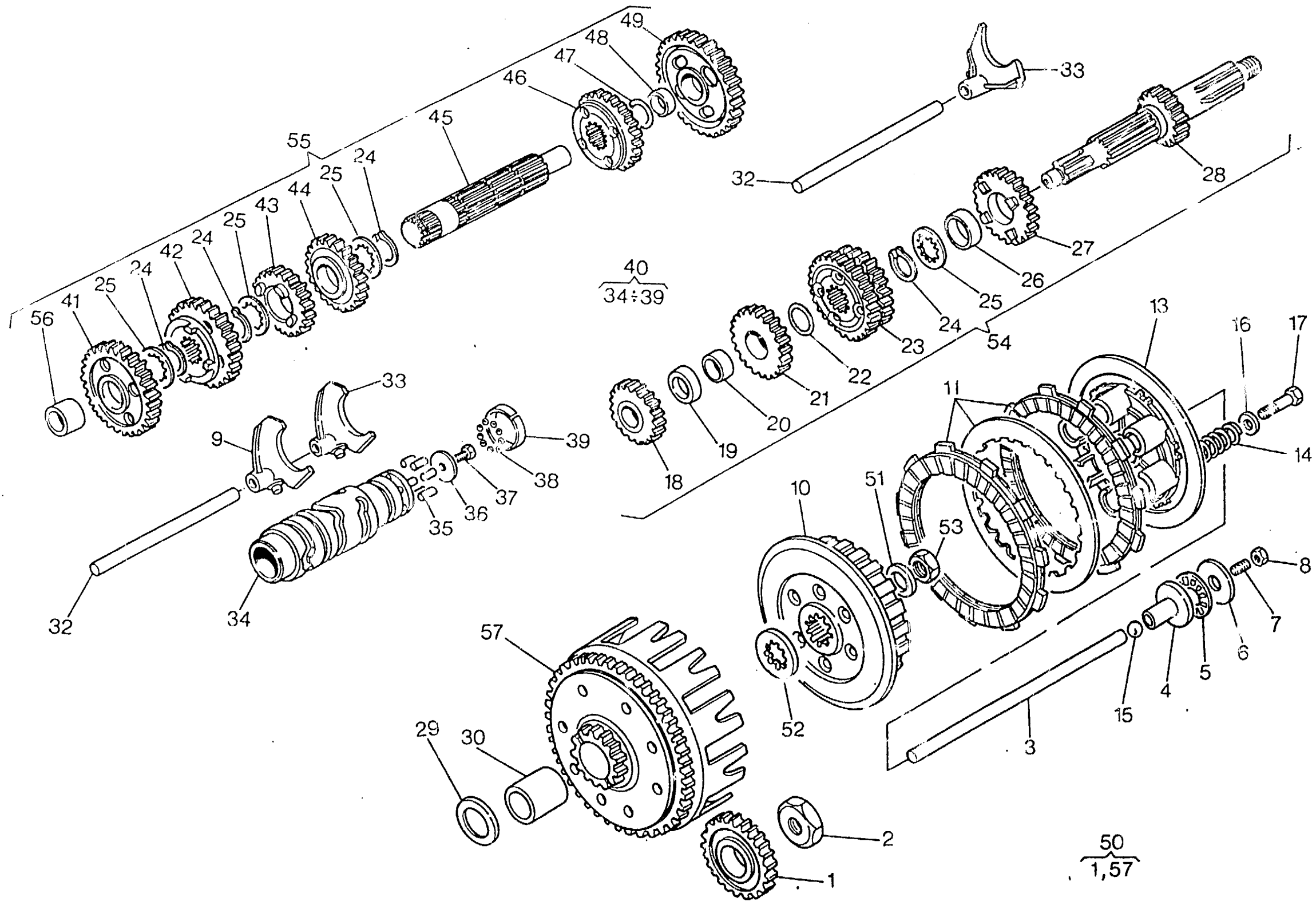



CAMBIO, COMANDO CAMBIO, FRIZIONE - TRANSMISSION, SHIFTER, CLUTCH
BOITE DE VITESSE, COMMANDE DE VITESSE, EMBRAYAGE
WECHSELGETRIEBE, GANGSCHALTUNG, KUPPLUNG - CAMBIO, MANDO CAMBIO, ENBRAGUE

(TE)

TAVOLA
DRAWING
TABLE
BILD
TABLA

8

TE - TC
610 / 95

Note Notes Marka Notas	Pos. No. Index Pos.	N. Cod. Code No. Nr. Code Code Nr N. Cod.	DENOMINAZIONE	NAME	DESIGNATION	BESHREIBUNG	DENOMINACION	Q.ta Q.ty M.ge C.ad	Valori Validity Validit Gültigk Validez
	55	8000 60470	Albero secondario completo	Layshaft compl.	Arbre secondaire compl.	Vorgelegewelle kpl.	Eje secundario completo compl.	1	
	56	8000 63822	Bussola	Bushing	Douille	Buchse	Manguito	1	
	57	8000 69722	Campana frizione completo	Clutch housing compl.	Cage embrayage compl.	Kupplungskorb kpl.	Campana embrague compl.	1	
			▲ = A richiesta	▲ = Upon request	▲ = Sur demande	▲ = Auf Anfrage	▲ = Bajo pedido		

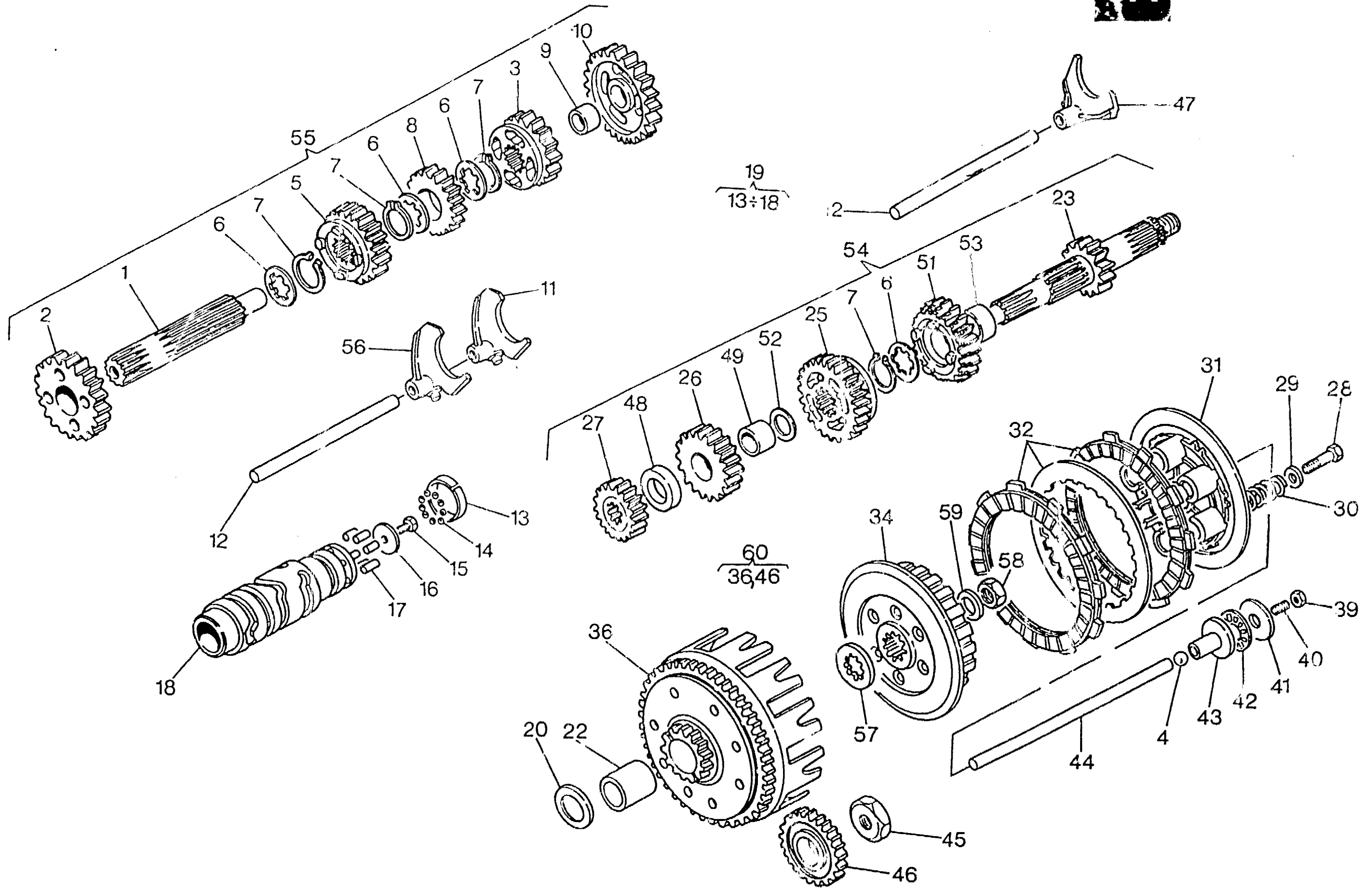



CAMBIO, COMANDO CAMBIO, FRIZIONE - TRANSMISSION, SHIFTER, CLUTCH
BOITE DE VITESSE, COMMANDE DE VITESSE, EMBRAYAGE
WECHSELGETRIEBE, GANGSCHALTUNG, KUPPLUNG - CAMBIO, MANLO CAMBIO, ENBRAGUE

(TC)

TAVOLA
DRAWING
TABLE
BILD
TABLA

8A

TE - TC
610 / 95

Note Notes Marka Notas	Pos. No. N. Index Pos.	N. Cod. Code No Nr. Code Code Nr N. Cod.	DENOMINAZIONE	NAME	DESIGNATION	BESCHREIBUNG	DENOMINACION	Q.tà Qty Q.te M.ge C.ad	Validità Validity Validé Gültig Validez
	1	8000 6052	Albero secondario	Layshaft	Arbre secondaire	Vorgelegewelle	Eje secundario	1	
	2	1616022-01	Ingranaggio 2° A.S.	Secondary shaft 2nd gear	Engrenage 2ème vitesse A.S.	Zahn. f. 2. Geschw. Vorgelegew.	Engranaje 2° velocidad Eje S.	1	
	3	1616024-01	Ingranaggio 4° A.S.	Secondary shaft 4th gear	Engrenage 4ème vitesse A.S.	Zahn. f. 4. Geschw. Vorgelegew.	Engranaje 4° velocidad Eje S.	1	
	4	68N0 21509	Sfera	Ball	Bille	Kugel	Esfera	1	
	5	8000 63432	Ingranaggio 3° A.S.	Secondary shaft 3rd gear	Engrenage 3ème vitesse A.S.	Zahn. f. 3. Geschw. Vorgelegew.	Engranaje 3° velocidad Eje S.	1	
	6	1611717-01	Rosetta	Washer	Rondelle	Scheibe	Arandela	4	
	7	66N0 21211	Anello di fermo	Stop ring	Bague d'arrêt	Haltering	Anillo de retención	4	
	8	1616025-01	Ingranaggio 5° A.S.	Secondary shaft 5th gear	Engrenage 5ème vitesse A.S.	Zahn. f. 5. Geschw. Vorgelegew.	Engranaje 5° velocidad Eje S.	1	
	9	1612415-01	Bussola	Bushing	Douille	Buchse	Manguito	1	
	10	1616021-01	Ingranaggio 1° A.S.	Gear 1st speed	Engrenage 1ère	Zahnrad 1. Gang	Engranaje 1° velocidad	1	
	11	1612384-01	Forcella cambio	Fork	Fourche	Gabel	Horquilla	1	
	12	1611699-01	Perno	Pin	Pivot	Bolzen	Perno	2	
	13	1612699-01	Anello esterno	Ring	Bague	Ring	Anillo		
	14	8000 60472	Sfera	Ball	Bille	Kugel	Esfera	11	
	15	8000 60473	Vite	Screw	Vis	Schraube	Tornillo	1	
	16	8000 30326	Rosetta	Washer	Rondelle	Scheibe	Arandela	1	
	17	8000 35823	Rullino	Roller	Aiguille	Rolle	Rodillo	6	
	19	1616354-01	Albero forcelle cambio compl.	Driving shaft gearbox forks	Arbre comm. fourches trans.	Antriebswelle Schaltgabel	Eje mando horquilla cambio	1	
	20	8E00 30053	Rosetta di rasamento	Washer	Rondelle	Scheibe	Arandela	1	
	22	1615388-01	Bussola	Bushing	Douille	Buchse	Manguito	1	
	23	8000 69633	Albero primario	Main shaft	Arbre primaire	Hauptwelle	Eje primario	1	
	25	1616020-01	Ingranaggio 5° A.P.	Gear 5th speed	Engrenage 5ème	Zahnrad 5. Gang	Engranaje 5° velocidad	1	
	26	1616037-01	Ingranaggio 3° A.P.	Main shaft 3rd gear	Engrenage 3ème vitesse A.P.	Zahn. f. 3. Geschw. Antriebsw.	Engranaje 3° velocidad Eje P.	1	
	27	1616017-01	Ingranaggio 2° A.P.	Main shaft 2nd gear	Engrenage 2ème vitesse A.P.	Zahn. f. 2. Geschw. Antriebsw.	Engranaje 2° velocidad Eje P.	1	
	28	60N10 1081	Vite	Screw	Vis	Schraube	Tornillo	5	
	29	8000 21535	Rosetta	Washer	Rondelle	Scheibe	Arandela	5	
	30	8000 71230	Molla frizione	Clutch spring	Ressort embrayage	Kupplungsfeder	Resorte embrague	5	
▲	30	8000 42473	Molla frizione	Clutch spring	Ressort embrayage	Kupplungsfeder	Resorte embrague	5	

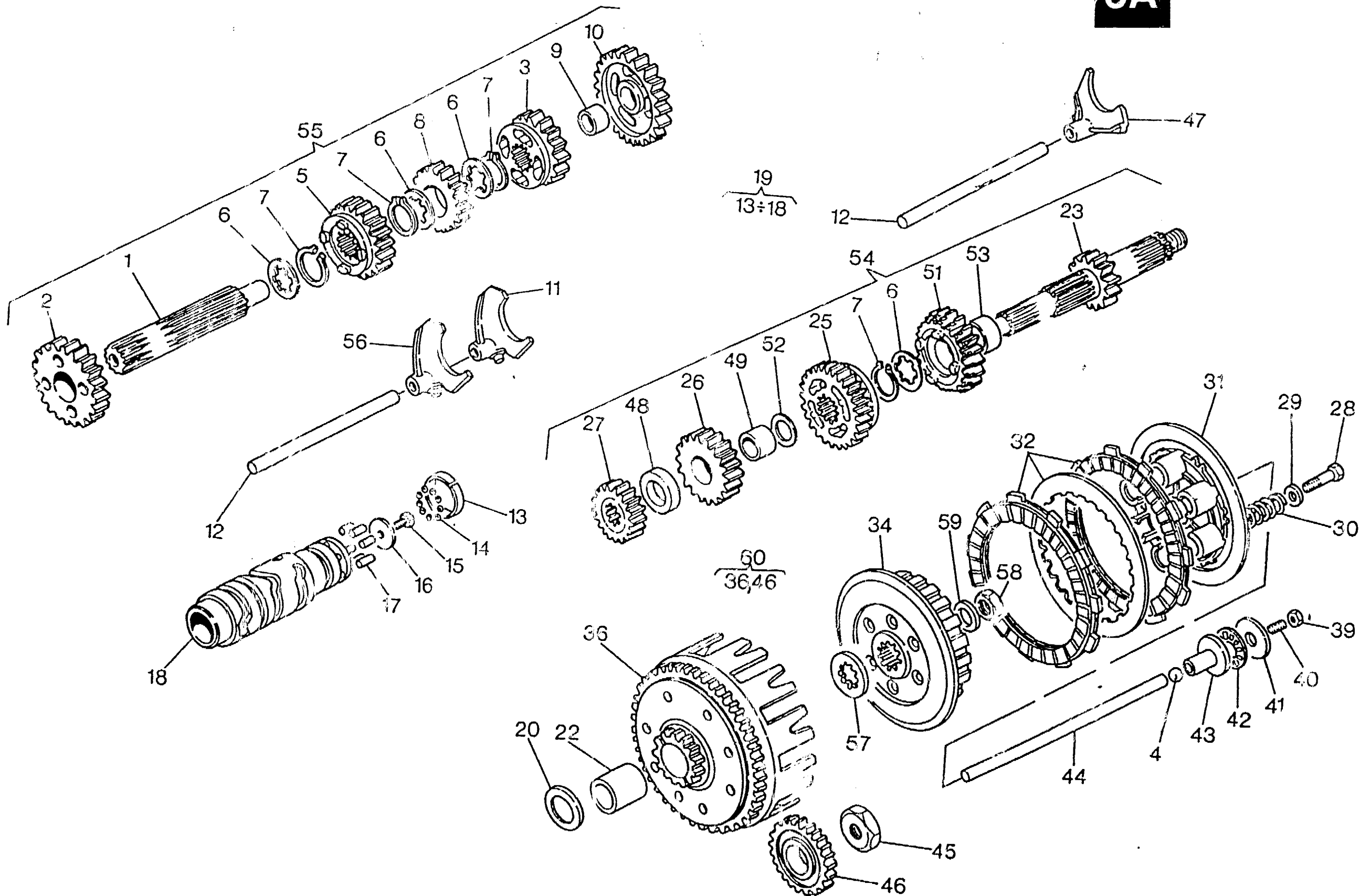



CAMBIO, COMANDO CAMBIO, FRIZIONE - TRANSMISSION, SHIFTER, CLUTCH
BOITE DE VITESSE, COMMANDE DE VITESSE, EMBRAYAGE
WECHSELGETRIEBE, GANGSCHALTUNG, KUPPLUNG - CAMBIO, MANDO CAMBIO, ENBRAGUE

(TC)

TAVOLA
DRAWING
TABLE
BILD
TABLA

8A

TE - TC
610 / 95

Note Notes Marka Notas	Pos. No. N. Index Pos.	N. Cod. Code No. Nr. Code Co. Je Nr N. Cod.	DENOMINAZIONE	NAME	DE. SIGNATION	BESHREIBUNG	DENOMINACION	Q.ta Q.ty Q.té M.ge C.ad	Validità Validité Validig Validez
	31	8000 48138	Piastra spingidischi	Plate	Plaque	Platte	Placa	1	
	32	8E00 82861	Ass. gruppo frizione	Clutch group assy	Groupe embrayage compl.	Kupplungsgruppe Kpl	Grupo embrague compl.	1	
	34	8A00 48137	Mozzo frizione	Hub	Moyeau	Radnabe	Cubo	1	
	36	8000 69722	Campana frizione completo	Clutch housing compl.	Cage embrayage compl.	Kupplungskorb kpl.	Campana embrague compl.	1	
	39	61N1 15062	Dado	Nut	Ecrou	Mutter	Tuerca	1	
	40	8000 54692	Vite	Screw	Vis	Schraube	Tomillo	1	
	41	8000 35781	Rosetta	Washer	Rondelle	Scheibe	Arandela	1	
	42	8000 35780	Cuscinetto assiale	Bearing	Roulement	Kugellager	Cojinete	1	
	43	8000 54477	Piattello	Plate	Plateau	Teller	Placa	1	
	44	1615315-02	Asta di forza	Fork tube	Barre de force	Druckstab	Varilla de fuerza	1	
	45	8000 59965	Dado	Nut	Ecrou	Mutter	Tuerca	1	
	46	8000 69715	Ingranaggio conduttore	Driving gear	Engrange conducteur	Zahnrad	Engranaje conductor	1	
	47	1616015-01	Forcella cambio	Fork	Fourche	Gabel	Horquilla	1	
	48	1616027-01	Distanziale	Spacer	Entretoise	Distanzstück	Separador	1	
	49	1616360-01	Bussola	Bushing	Douille	Buchse	Manguito	1	
	51	1616019-01	Ingranaggio 4 ^a A.P.	Main shaft 4th gear	Engrenage 4ème vitesse A.P.	Zahnr. f. 4. Geschw. Antriebsw.	Engranaje 4° velocidad Eje P.	1	
	52	1612842-01	Rosetta	Washer	Rondelle	Scheibe	Arandela	1	
	53	8000 63798	Bussola	Bushing	Douille	Buchse	Manguito	1	
	54	8000 69738	Albero primario completo	Main shaft	Arbre primaire	Hauptwelle	Eje principal completo	1	
	55	8000 60525	Albero secondario completo	Layshaft compl.	Arbre secondaire compl.	Vorgelegewelle kpl.	Eje secundario completo compl.	1	
	56	8000 63425	Forcella 3 ^a vel. sul secondario	Fork	Fourche	Gabel	Horquilla	1	
	57	8A00 38350	Rosetta	Washer	Rondelle	Scheibe	Arandela	1	
	58	8000 36856	Dado	Nut	Ecrou	Mutter	Tuerca	1	
	59	8000 36857	Rosetta di sicurezza	Washer	Rondelle	Scheibe	Arandela	1	
	60	8000 69729	Coppia ingran. trasm. primaria	Set of matched primary	Engrenages trans. prim.	Stirnradpaar	Copla engranaje trans. primaria	1	
			▲ = A richiesta	▲ = Upon request	▲ = Sur demande	▲ = Auf Anfrage	▲ = Bajo pedido		

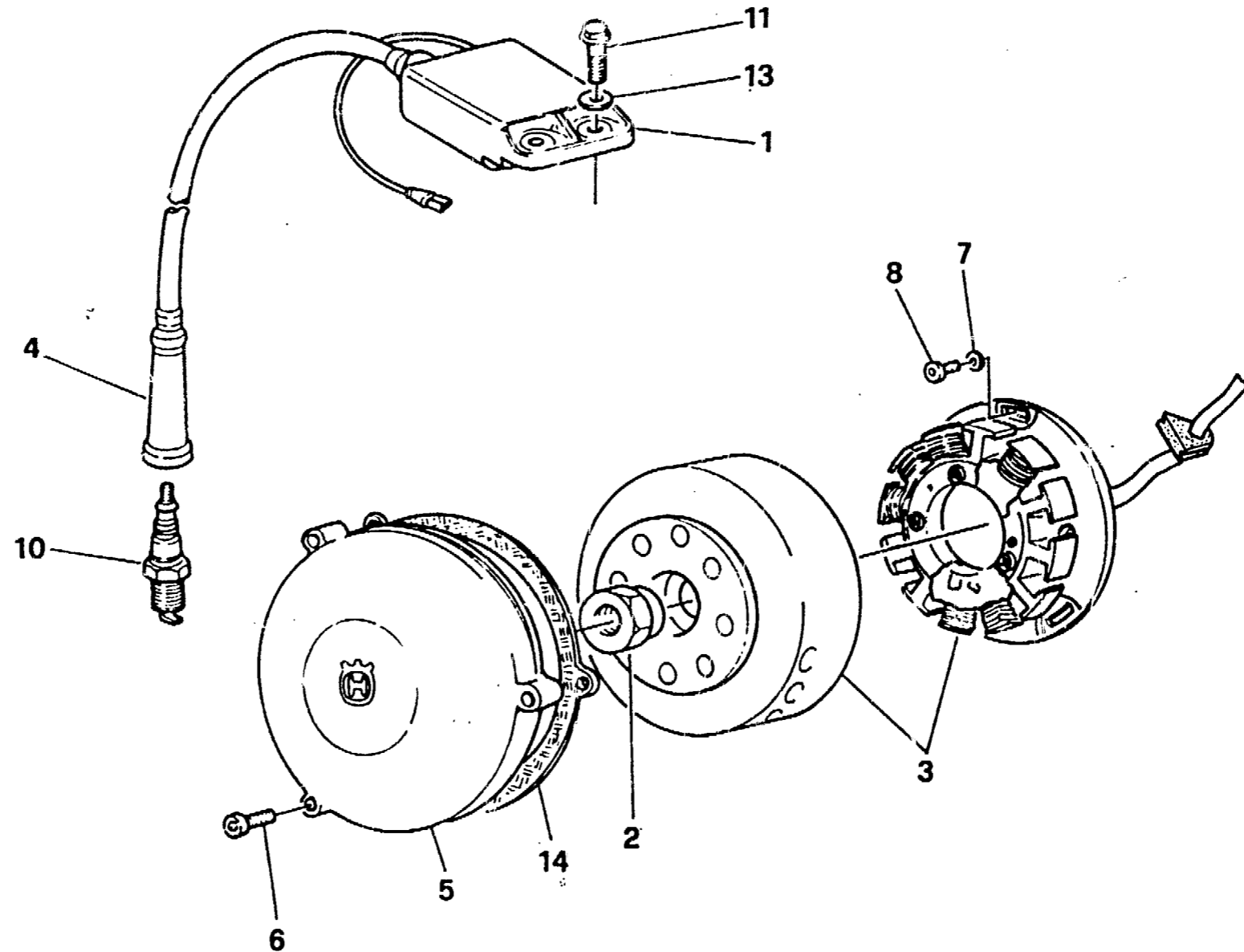



ACCENSIONE - IGNITION
ALLUMAGE - ZUNDUNG
ENCENDIDO

TAVOLA
DRAWING
TABLE
BILD
TABLA

9

TE - TC
610 / 95

Note Notes Notas	Pos. No. N. Index Pos.	N. Cod. Code No. Nr. Code Code Nr N. Cod.	DENOMINAZIONE	NAME	DESIGNATION	BESHREIBUNG	DENOMINACION	Q.tà Qty Q.té M.ge Cad	Valità Validity Validité Gültig Validez
	1	8000 75451	Bobina completa	Coil compl.	Bobine compl.	Zündspule kpl.	Bobina compl.	1	
	2	8A00 59964	Dado	Nut	Ecrou	Mutter	Tuerca	1	
	3	8000 77391	Alternatore compl.	Alternator compl.	Alternateur compl.	Lichtmaschine kpl.	Alternador compl.	1	
	4	1615382-01	Cappuccio candela	Cap	Capuchon	Kappe	Capuchón	1	
	5	80C0 60559	Coperchio accensione	Cover	Couvercle	Deckel	Tapa	1	
	6	60N10 2513	Vite	Screw	Vis	Schraube	Tornillo	3	
	7	8000 36137	Rosetta	Washer	Rondelle	Scheibe	Arandela	3	
	8	60N10 2487	Vite	Screw	Vis	Schraube	Tornillo	3	
◆	10	1615383-01	Candela NGK	Spark plug	Bougie	Zündkerze	Bujía	1	
◆	10	8000 77478	Candela CHAMPION	Spark plug	Bougie	Zündkerze	Bujía	1	
	11	8C00 67997	Vite	Screw	Vis	Schraube	Tornillo	2	
	13	62N4 15548	Rosetta	Washer	Rondelle	Scheibe	Arandela	2	
	14	1615275-01	Guarnizione	Gasket	Garniture	Dichtung	Junta	1	
			◆ = In alternativa	◆ = In alternative	◆ = En alternative	◆ = Die Auswahl	◆ = En alternativa		

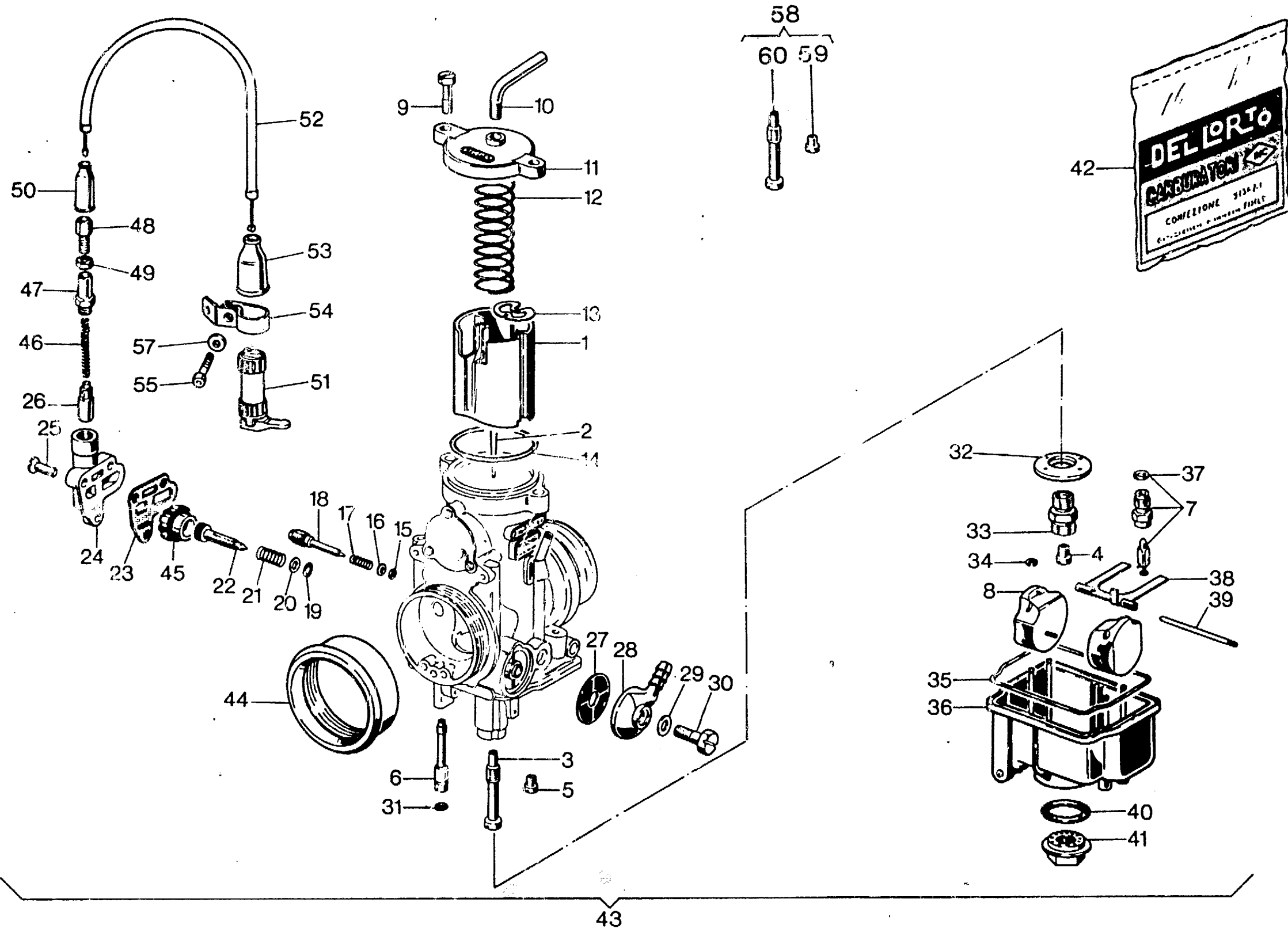



**CARBURATORE - CARBURETOR
CARBURATEUR - VERGASER
CARBURADOR**

(TE)

TAVOLA
DRAWING
TABLE
BILD
TABLA

10

**TE - TC
610 / 95**

Notes Notes Marka Notas	Pos. No. N. Index Pos.	N. Cod. Code No. Nr. Code Code Nr N. Cod.	DENOMINAZIONE	NAME	DESIGNATION	BESCHREIBUNG	DENOMINACION	Q.tà Qty Q.te M.ge C.ød	Valida Valokiv Valokiv Gultig Valokiv
	1	8000 60479	Valvola gas da 50	Throttle valve	Papillon de gaz	Drosselklappe	Válvula	1	
	2	8000 27910	Spillo conico K32	Needle	Pointeau conique	Kon. Nadel	Pasador cónico	1	
	3	8000 24058	Polverizzatore 264 AB	Fuel nozzle	Fulvérisateur	Einspritzdüse	Pulverizador	1	
	4	8000 12041	Getto massimo 175	Main jet	Gicleur principal	Hauptdüse	Chiclé máximo	1	
	5	8000 5761	Getto minimo da 62	Idle jet	Gicleur minimum	Leerlaufdüse	Chiclé mínimo	1	
	6	8000 12032	Getto avviamento da 60	Starting jet	Gicleur de starter	Starterdüse	Chicle arranque	1	
	7	8000 33109	Valvola a spillo 300	Needle valve	Soupape à pointeau	Nadelventil	Válvula de aguja	1	
	8	8000 29665	Galleggiante g.3,5	Float	Floteur	Schwimmer	Flotador	2	
	9	8000 23981	Vite	Screw	Vis	Schraube	Tomillo	2	
	10	8000 67457	Tubetto	Tube	Tuyau	Rohr	Tubo	1	
	11	8000 60480	Coperchio	Cover	Couvercle	Deckel	Tapa	1	
	12	8000 40578	Molla	Spring	Ressort	Feder	Resorte	1	
	13	8000 23979	Fermaglio	Retainer	Arret	Klammer	Abrazadera de sujeción	1	
	14	●	Guarnizione	Gasket	Garnitue	Dichtung	Junta	1	
	15	●	Guarnizione	Gasket	Garnitue	Dichtung	Junta	1	
	16	8000 23985	Rosetta piana	Washer	Rondelle	Scheibe	Arandela	1	
	17	8000 12034	Molla	Spring	Ressort	Feder	Resorte	1	
	18	8000 12033	Vite regolazione minimo	Idling mixture adj. screw	Vis réglage mélange de ralenti	Regulierschraube	Tomillo regul. mezcla relenti	1	
	19	●	Guarnizione	Gasket	Garnitue	Dichtung	Junta	1	
	20	8000 23983	Rosetta piana	Washer	Rondelle	Scheibe	Arandela	1	
	21	8000 12030	Molla	Spring	Ressort	Feder	Resorte	1	
	22	8000 12029	Vite registro valvola gas	Throttle adj. screw	Vis réglage papillon	Drosseleinstellschraube	Tomillo	1	
	23	●	Guarnizione	Gasket	Garnitue	Dichtung	Junta	1	
	24	8000 28799	Corpo dispositivo avviamento	Starter body	Corps démarrage	Körper Anlass	Cuerpo puesta en marcha	1	
	25	8000 28798	Vite	Screw	Vis	Schraube	Tomillo	3	
	26	8000 40580	Dispositivo avviamento	Starting device	Dispositif de Démarrage	Startvorrichtung	Dispositivo puesta en marcha	1	

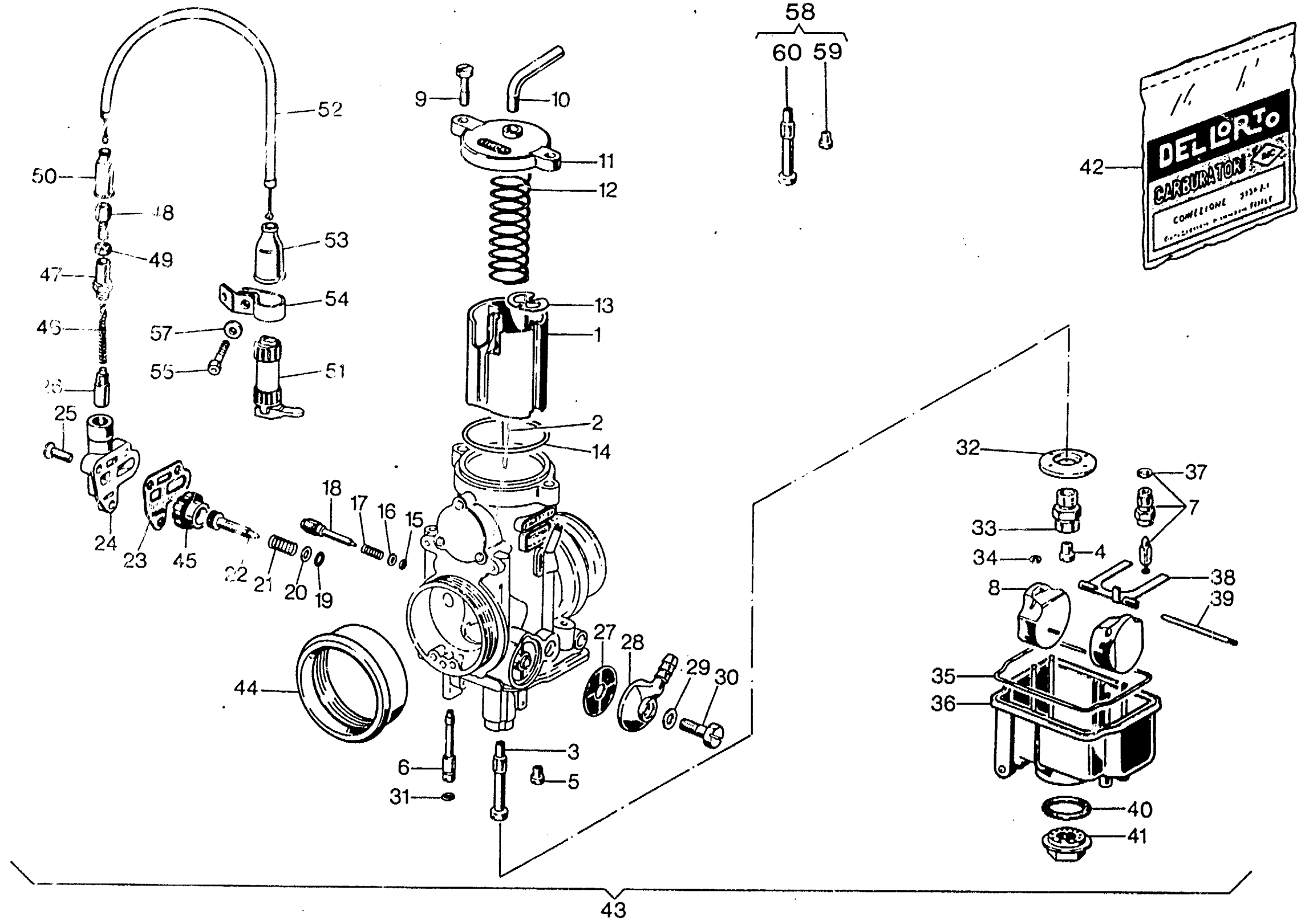



CARBURATORE - CARBURETOR
CARBURATEUR - VERGASER
CARBURADOR

(TE)

TAVOLA
DRAWING
TABLE
BILD
TABLA

10

TE - TC
610 / 95

Note Notes Notas	Pos. No. N. Index	N. Cod. Code No. Nr. Code Code Nr. N. Cod.	DENOMINAZIONE	NAME	DESIGNATION	BESCHREIBUNG	DENOMINACION	C. U. C. U. C. U. M. g. C. ad	Valida Validy Validé Validé Validé
	27	8000 12045	Filtro benzina	Fuel filter	Filtre essence	Benzinfilter	Filtro gasolina	1	
	28	8000 12046	Pipetta	Pipette	Pipette	Pipette	Pipa	1	
	29	●	Guarnizione	Gasket	Garnitue	Dichtung	Junta	1	
	30	8000 12048	Vite	Screw	Vis	Schraube	Tomillo	1	
	31	●	Guarnizione	Gasket	Garnitue	Dichtung	Junta	1	
	32	8000 32866	Fondello	Bottom	Fond	Bodenscheibe	Casquillo	1	
	33	8000 23990	Portagetto	Jet-holder	Porte-gicleur	Düsenträger	Porta-chiclé	1	
	34	8000 32865	Fermaglio	Retainer	Arret	Klammer	Abrazadera de sujeción	2	
	35	●	Guarnizione	Gasket	Garnitue	Dichtung	Junta	1	
	36	8000 60502	Vaschetta	Chamber	Cuvette	Becken	Cubeta	1	
	37	●	Guarnizione	Gasket	Garnitue	Dichtung	Junta	1	
	38	8000 60501	Bilanciere	Rocking lever	Balancier	Schwinge	Balancines	1	
	39	8000 32867	Perno	Pin	Pivot	Bolzen	Perno	1	
	40	●	Guarnizione	Gasket	Garnitue	Dichtung	Junta	1	
	41	8000 33211	Tappo	Plug	Bouchon	Verschluss	Tapón	1	
	42	8000 60504	Busta guarnizioni	Gasket set	Jeu joints	Dichtungssatz	Serie juntas	1	
	43	8A00 67932	Carburatore completo	Carburetor assy	Carbureteur complet	Vergaser, kpl.	Carburador compl.	1	
	44	1615390-01	Cometto presa aria	Pipe	Manchon	Mulle	Tubo toma aire	1	
	45	8000 57413	Pomello	Knob	Poignée	Knopf	Pomo	1	
	46	8000 44043	Molla	Spring	Ressort	Feder	Resorte	1	
	47	8000 67458	Tappo	Plug	Bouchon	Verschluss	Tapón	1	
	48	80000 4103	Vite	Screw	Vis	Schraube	Tomillo	1	
	49	80000 4104	Dado	Nut	Ecrou	Mutter	Tuerca	1	
	50	8000 12451	Cappuccio	Cap	Capuchon	Kappe	Capuchón	1	
	51	8A00 40877	Leva comando starter	Lever	Levier	Hebel	Palanca	1	
	52	8000 67444	Trasmissione comando starter	Starter wire	Trasm. comm. starter	Anlassen Kabel	Transm. mando starter	1	

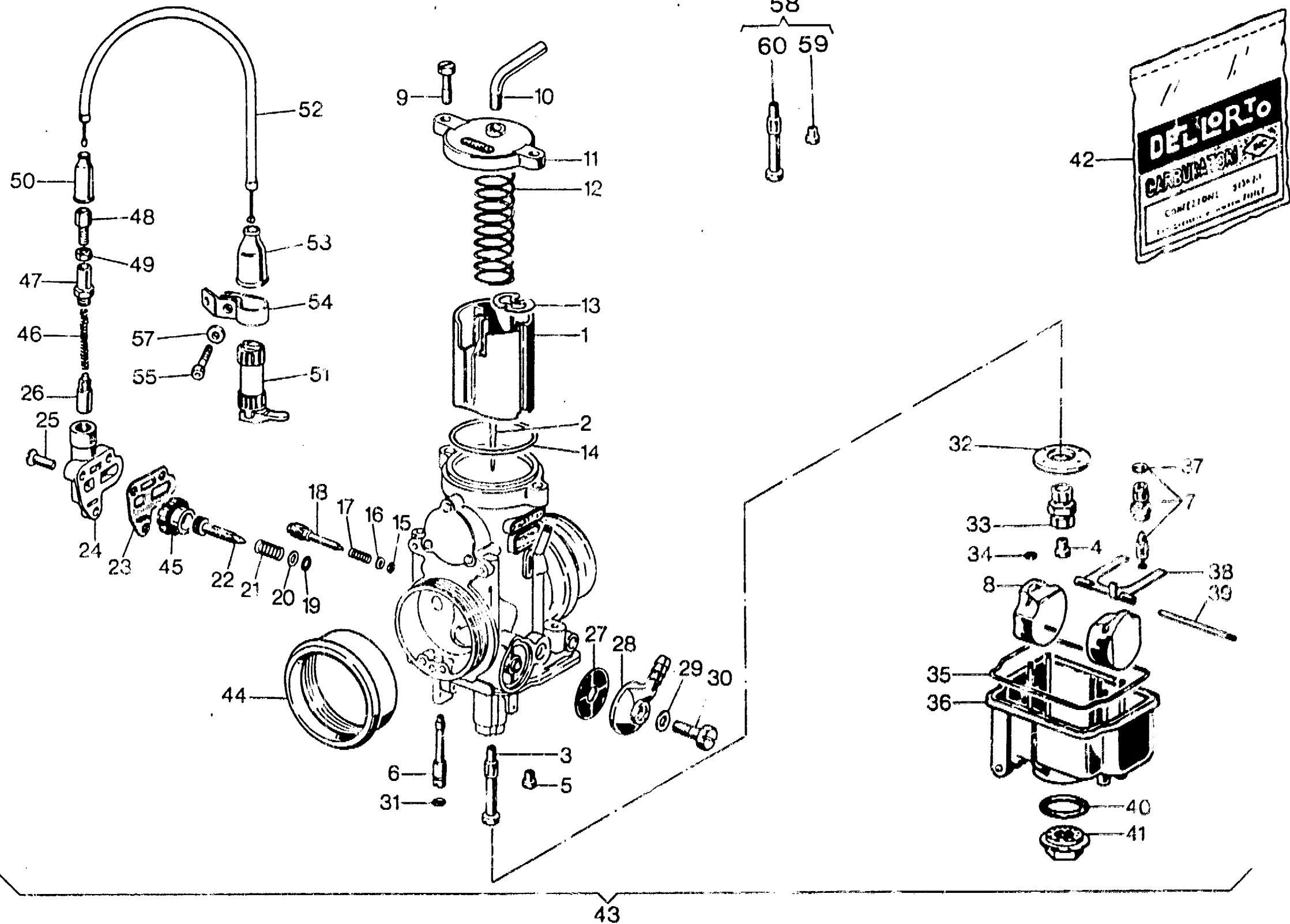



CARBURATORE - CARBURETOR
 CARBURATEUR - VERGASER
 CARBURADOR

(TE)

TAVOLA
 DRAWING
 TABLE
 BILD
 TABLA

10

TE - TC
 610 / 95

Note Notes Marka Notas	Pos. No. Index Pos.	N. Cod. Cod. No. Nr. Code Code Nr N. Cod.	DENOMINAZIONE	NAME	DESIGNATION	BESHREIBUNG	DENOMINACION	Q.tà Q.ty Q.té M.ge C.ad	Validà Validty Validé Gültig Validez
	53	8000 42980	Cappuccio	Cap	Capuchon	Kappe	Capuchón	1	
	54	8000 57434	Staffetta	Bracket	Etrier	Buegel	Brida	1	
	55	60N10 1048	Vite	Screw	Vis	Schraube	Tomillo	1	
	57	62N1 15503	Rosetta	Washer	Rondelle	Scheibe	Arandela	1	
■	58	8000 72092	Kit omologazione ECE	ECE homologation kit	Gr. homolog. ECE	Ratifikation ECE Gruppe	Kit homologacion ECE	1	
■	59	80C00 5761	Getto minimo da 55	Idle jet	Gicleur minimum	Leerlaufdüse	Chiclé mínimo	1	
■	60	80C0 24058	Polverizzatore 262 AB	Fuel nozzle	Pulvérisateur	Einspritzdüse	Pulverizador	1	
			● = Contenuto nella busta guarnizioni Pos.42 ■ = A richiesta	● = Gasket bag No.42 ■ = Upon request	● = Dans l'enveloppe à joints N 42 ■ = Sur demande	● = Imbeutel d. Dichtungen enthalt. Index 42 ■ = Auf Anfrage	● = En el saquito de guarniciones Pos.42 ■ = Bajo pedido		

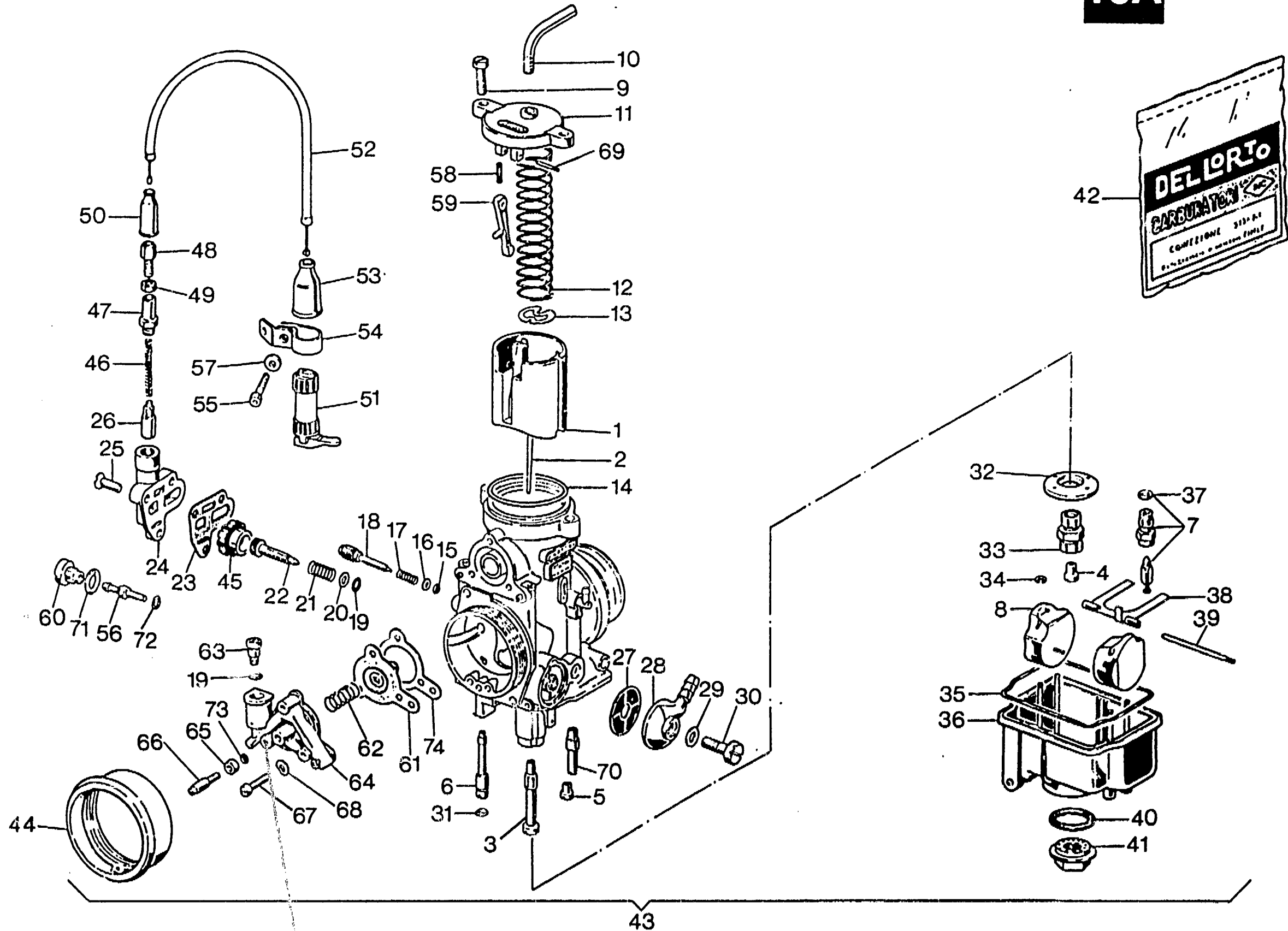



CARBURATORE - CARBURETOR
 CARBURATEUR - VERGASER
 CARBURADOR

(TC)

TAVOLA
 DRAWING
 TABLE
 BILD
 TABLA

10A

TE - TC
 610 / 95

Note Notes Notas	Pos. No. Index Pos.	N. Cod. Code No. Nr. Code Code Nr N. Cod.	DENOMINAZIONE	NAME	DESIGNATION	BESHREIBUNG	DENOMINACION	Q.tà Q.ty Q.te M.ge C.ad	Validità Validity Validité Gültig Validez
	1	8000 77878	Valvola gas da 50	Throttle valve	Papillon de gaz	Drosselklappe	Válvula	1	
	2	8Q00 27910	Spillo conico K32	Needle	Pointeau conique	Kon. Nadel	Pasador cónico	1	
	3	8C00 24058	Polverizzatore 264 AB	Fuel nozzle	Pulvérisateur	Einspritzdüse	Pulverizador	1	
	4	80U0 12041	Getto massimo 170	Main jet	Gicleur principal	Hauptdüse	Chiclé máximo	1	
	5	8GA00 5761	Getto minimo da 62	Idle jet	Gicleur minimum	Leerlaufdüse	Chiclé mínimo	1	
	6	80A0 12032	Getto avviamento da 60	Starting jet	Gicleur de starter	Starterdüse	Chiclé arranque	1	
	7	8000 33109	Valvola a spillo 300	Needle valve	Soupape à pointeau	Nadelventil	Válvula de aguja	1	
	8	8000 29665	Galleggiante g.3,5	Float	Flotteur	Schwimmer	Flotador	2	
	9	8000 23981	Vite	Screw	Vis	Schraube	Tomillo	2	
	10	8000 67457	Tubetto	Tube	Tuyau	Rohr	Tube	1	
	11	8000 60480	Coperchio	Cover	Couvercle	Deckel	Tapa	1	
	12	8000 22466	Molla	Spring	Ressort	Feder	Resorte	1	
	13	8000 23979	Fermaglio	Retainer	Arret	Klammer	Abrazadera de sujeción	1	
	14	●	Guarnizione	Gasket	Garnitue	Dichtung	Junta	1	
	15	●	Guarnizione	Gasket	Garnitue	Dichtung	Junta	1	
	16	8000 23985	Rosetta piana	Washer	Rondelle	Scheibe	Arandela	1	
	17	8000 12034	Molla	Spring	Ressort	Feder	Resorte	1	
	18	8000 12033	Vite regolazione minimo	Idling mixture adj. screw	Vis réglage mélange de ralenti	Regulierschraube	Tomillo regul. mezcla ralentí	1	
	19	●	Guarnizione	Gasket	Garnitue	Dichtung	Junta	1	
	20	8000 23983	Rosetta piana	Washer	Rondelle	Scheibe	Arandela	1	
	21	8000 12030	Molla	Spring	Ressort	Feder	Resorte	1	
	22	8000 12029	Vite registro valvola gas	Throttle adj. screw	Vis réglage papillons	Drosseleinstellschraube	Tomillo	1	
	23	●	Guarnizione	Gasket	Garnitue	Dichtung	Junta	1	
	24	8000 28799	Corpo dispositivo avviamento	Starter body	Corps démarrage	Körper Anlass	Cuerpo puesta en marcha	1	
	25	8000 28798	Vite	Screw	Vis	Schraube	Tomillo	3	
	26	8000 40580	Dispositivo avviamento	Starting device	Dispositif de démarrage	Startvorrichtung	Dispositivo puesta en marcha	1	

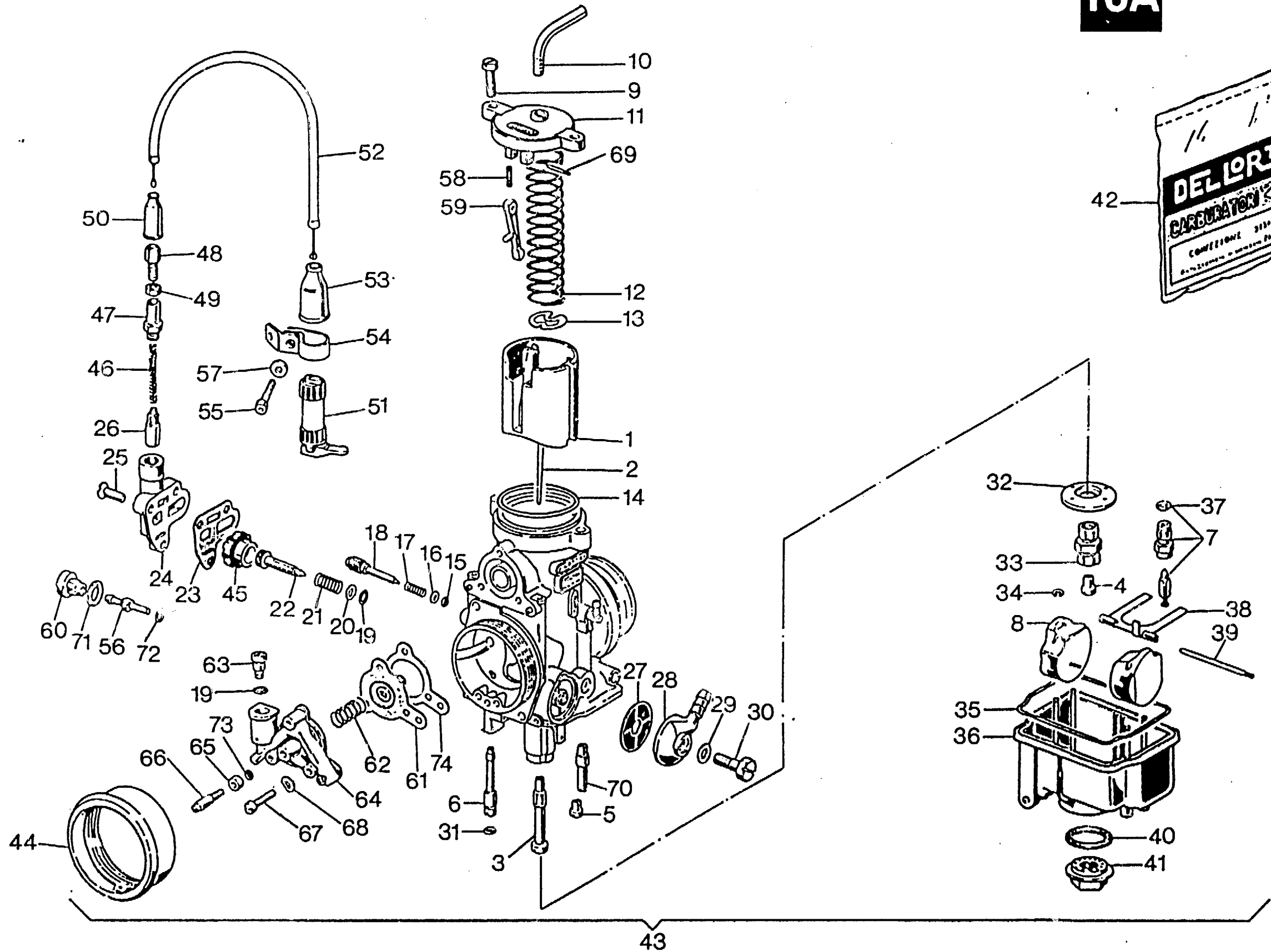



CARBURATORE - CARBURETOR
 CARBURATEUR - VERGASER
 CARBURADOR

(TC)

TAVOLA
 DRAWING
 TABLE
 BILD
 TABLA

10A

TE - TC
 610 / 95

Note Notes Notas	Pos. No. Index Pos.	N. Cod. Code No. Nr. Code Code Nr N. Cod.	DENOMINAZIONE	NAME	DESIGNATION	BESHREIBUNG	DENOMINACION	Q.tà Q.ty Q.te M.ge C.ad	Validità Validity Validez Gültig Vakdez
	27	8000 12045	Filtro benzina	Fuel filter	Filtre essence	Benzinfilter	Filtro gasolina	1	
	28	8000 12046	Pipetta	Pipette	Pipette	Pipette	Pipa	1	
	29	●	Guarnizione	Gasket	Garnitue	Dichtung	Junta	1	
	30	8000 12048	Vite	Screw	Vis	Schraube	Tomillo	1	
	31	●	Guarnizione	Gasket	Garnitue	Dichtung	Junta	1	
	32	8000 32866	Fondello	Bottom	Fond	Bodenscheibe	Casquillo	1	
	33	8000 23990	Portagetto	Jet-holder	Porte-gicleur	Düsenträger	Porta-chiclé	1	
	34	8000 32865	Fermaglio	Retainer	Arret	Klammer	Abrazadera de sujeción	2	
	35	●	Guarnizione	Gasket	Garnitue	Dichtung	Junta	1	
	36	8000 60502	Vaschetta	Chamber	Cuvette	Becken	Cubeta	1	
	37	●	Guarnizione	Gasket	Garnitue	Dichtung	Junta	1	
	38	8000 60501	Bilanciere	Rocking lever	Balancier	Schwinge	Balancines	1	
	39	8000 32867	Perno	Pin	Pivot	Bolzen	Perno	1	
	40	●	Guarnizione	Gasket	Garnitue	Dichtung	Junta	1	
	41	8000 33211	Tappo	Plug	Bouchon	Verschluss	Tapón	1	
	42	8000 77879	Busta guarnizioni	Gasket set	Jeu joints	Dichtungssatz	Serie juntas	1	
	43	8000 75847	Carburatore completo	Carburetor assy	Carbureteur complet	Vegaser, kpl.	Carburador compl.	1	
	44	1615390-01	Cornetto presa aria	Pipe	Manchon	Muffe	Tubo toma aire	1	
	45	8000 57413	Pomello	Knob	Poignée	Knopf	Pomo	1	
	46	8000 44043	Molla	Spring	Ressort	Feder	Resorte	1	
	47	8000 67458	Tappo	Plug	Bouchon	Verschluss	Tapón	1	
	48	80000 4103	Vite	Screw	Vis	Schraube	Tomillo	1	
	49	80000 4104	Dado	Nut	Ecrou	Mutter	Tuerca	1	
	50	8000 12451	Cappuccio	Cap	Capuchon	Kappe	Capuchón	1	
	51	8A00 40877	Leva comando starter	Lever	Levier	Hebel	Palanca	1	
	52	8000 67444	Trasmissione comando starter	Starter wire	Trasm. comm. starter	Anlassen Kabel	Transm. mando starter	1	

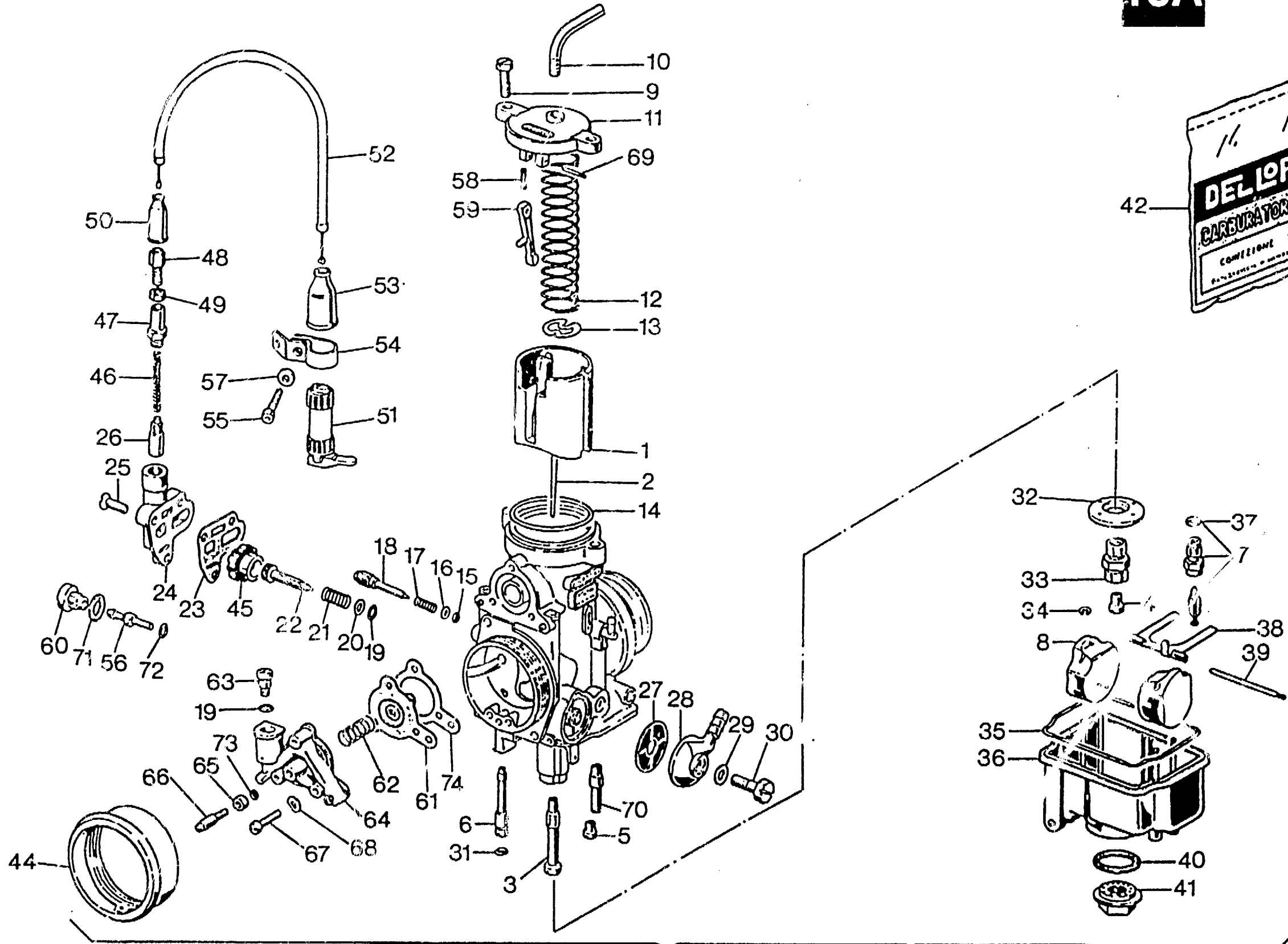



CARBURATORE - CARBURETOR
 CARBURATEUR - VERGASER
 CARBURADOR

(TC)

TAVOLA
 DRAWING
 TABLE
 BILD
 TABLA

10A

TE - TC
 610 / 95

Note Notes Notas	Pos. No. Index Pos.	N. Cod. Code No. Nr. Code Code Nr. N. Cod.	DENOMINAZIONE	NAME	DESIGNATION	BESHREIBUNG	DENOMINACION	Q.tà Q.ty Q.te M.ge C.ad	Validità Validity Valdité Gültig Validez
	53	8000 42980	Cappuccio	Cap	Capuchon	Kappe	Capuchón	1	
	54	8000 67434	Staffetta	Bracket	Etrier	Buegel	Brida	1	
	55	60N10 1048	Vite	Screw	Vis	Schraube	Tornillo	1	
	56	8080 40596	Getto pompa 48	Pump jet	Gicleur pompe	Pumpendüse	Chiclé bomba	1	
	57	62N1 15503	Rosetta	Washer	Rondelle	Scheibe	Arandela	1	
	58	8000 40586	Molla	Spring	Ressort	Feder	Resorte	1	
	59	8000 42955	Leva coman. pompa	Lever	Levier	Hebel	Palanca	1	
	60	8000 40597	Portagetto	Jet-holder	Porte-gicleur	Düsenträger	Porta-chiclé	1	
	61	8000 40593	Membrana pompa	Pump diaphragm	Diaphragme pompe	Pumpenmembrane	Membrana bomba	1	
	62	8000 40594	Molla	Spring	Ressort	Feder	Resorte	1	
	63	8000 40595	Valvola mandata pompa	Pump del. valve	Soupape réfoul. pompe	Pumpendruckventil	Válvula envío bomba	1	
	64	8000 40598	Coperchio	Cover	Couvercle	Deckel	Tapa	1	
	65	8000 40592	Dado	Nut	Ecrou	Mutter	Tuerca	1	
	66	8000 40591	Vite	Screw	Vis	Schraube	Tornillo	1	
	67	8000 40589	Vite	Screw	Vis	Schraube	Tornillo	3	
	68	8000 40590	Rosetta	Washer	Rondelle	Scheibe	Arandela	3	
	69	8000 40587	Perno leva coman. pompa	Pin	Pivot	Bolzen	Perno	1	
	70	8000 40584	Valvola aspirazione	Inlet valve	Soupape admission	Einlass-Ventil	Válvula aspiración	1	
	71	●	Guarnizione	Gasket	Garnitue	Dichtung	Junta	1	
	72	●	Guarnizione	Gasket	Garnitue	Dichtung	Junta	1	
	73	●	Guarnizione	Gasket	Garnitue	Dichtung	Junta	1	
	74	●	Guarnizione	Gasket	Garnitue	Dichtung	Junta	1	

● = Contenuto nella busta guarnizioni Pos.42

● = Gasket bag No.42

● = Dans l'enveloppe à joints N 42

● = Imbeutel d. Dichtungen enthalt. Index 42

● = En el saquito de guarniciones Pos.42

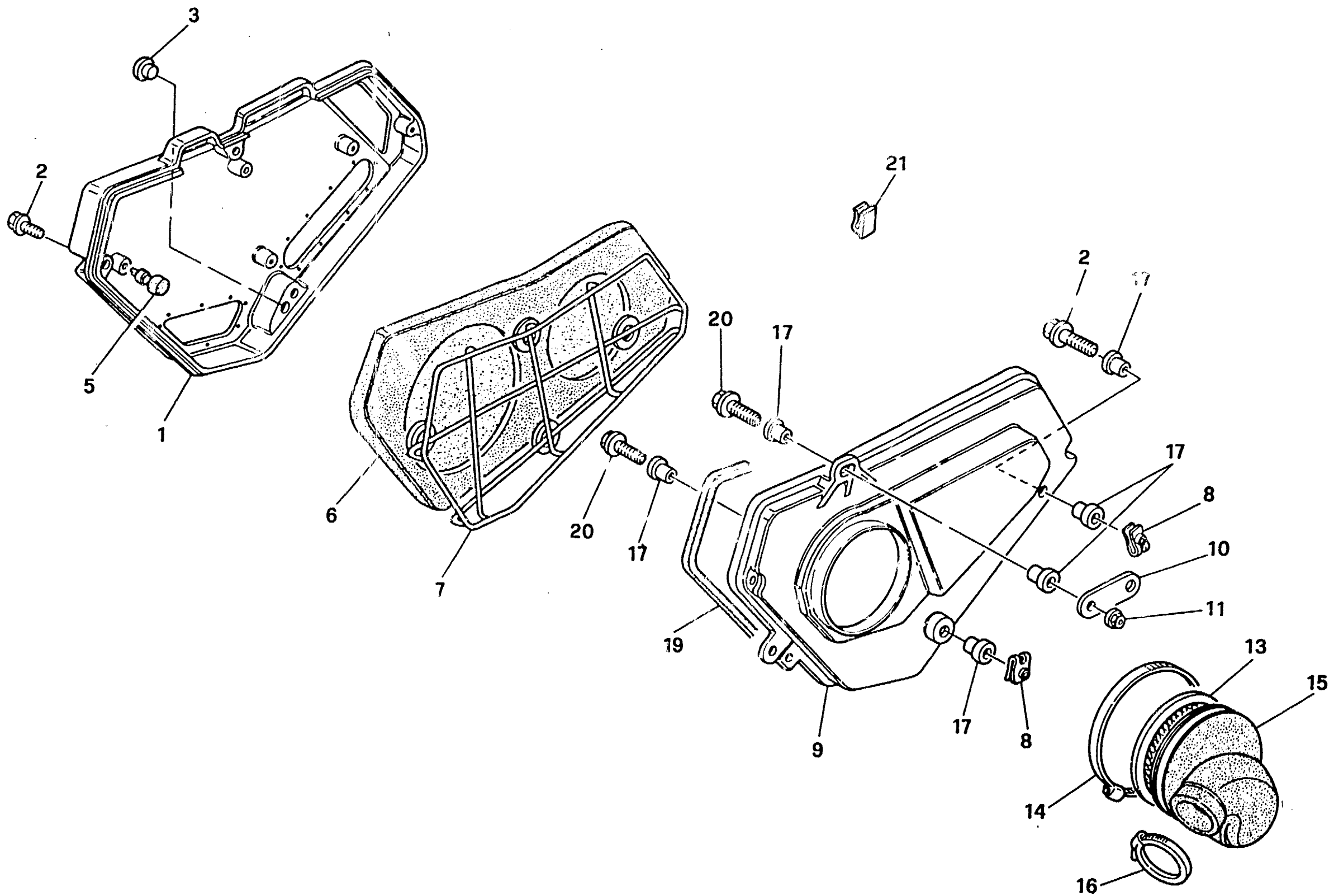



FILTRO ARIA - AIR FILTER
FILTRE AIRE - AIRFILTER
FILTRO DE AIRE

TAVOLA
DRAWING
TABLE
BILD
TABLA

11

TE - TC
610 / 95

Note Notes Mark Notas	Pos. No. Index Pos.	N. Cod. Code No. N. Code Code Nr N. Cod.	DENOMINAZIONE	NAME	DESIGNATION	BESHREIBUNG	DENOMINACION	Q.tà Q.ty Q.té M.ge C.ad	Validità Validity Validé Gültig Validez
	1	8A00 69782	Coperchio	Cover	Couvercle	Deckel	Tapa	1	
	2	8000 62727	Vite	Screw	Vis	Schraube	Tornillo	2	
	3	8000 55101	Tappo	Plug	Bouchon	Verschluss	Tapón	1	
	5	8000 67970	Tampone	Pad	Tampon	Stopfen	Tampón	1	
	6	9000 69783	Filtro aria	Air filter	Filtre à air	Luftfilter	Filtro aire	1	
	7	8000 69784	Gabbia filtro	Cleaner cage	Cage pour filtre	Filterkafig	Caja filtro	1	
	8	8000 46893	Dado	Nut	Ecrou	Mutter	Tuerca	2	
	9	80A0 75671	Scatola filtro	Air filter box	Boîte filtre	Filterkasten	Caja filtro aire	1	
	10	1515803-01	Piastrina	Plate	Plaquette	Plättchen	Placa	1	
	11	8000 44240	Dado	Nut	Ecrou	Mutter	Tuerca	1	
	13	8000 75673	Protezione	Guard	Protection	Schutz	Protección	1	
	14	8F00 56515	Fascetta	Clamp	Collier	Schelle	Banda	1	
	15	8000 75672	Raccordo	Union	Raccord	Anschluss	Empalme	1	
	16	8000 37906	Fascetta	Clamp	Collier	Schelle	Banda	1	
	17	8000 45495	Bussola	Bushing	Douille	Buchse	Manguito	3	
	19	8A00 60652	Guarnizione	Gasket	Garnitue	Dichtung	Junta	1	
	20	8000 62728	Vite	Screw	Vis	Schraube	Tornillo	4	
	21	8000 56806	Gancio adesivo	Hook	Crochet	Haken	Gancho	1	

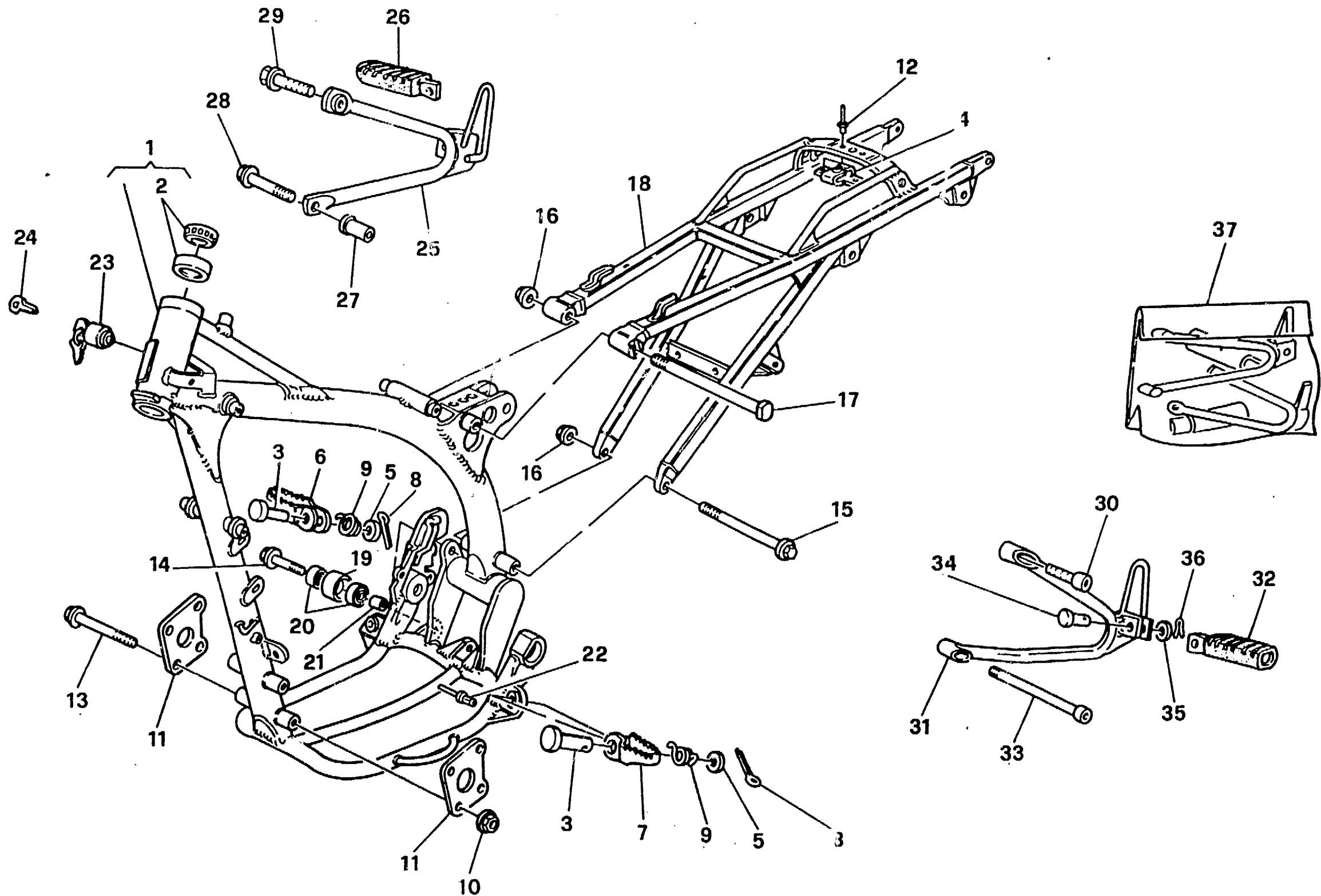



**TELAIO, PEDANE - FRAME, FOOT RESTS
CADRE, REPOSE PIEDS - RAHMEN, FUSSBRETT
BASTIDOR, REPOSAPIES**

TAVOLA
DRAWING
TABLE
BILD
TABLA

12

**TE - TC
610 / 95**

Note Notes Notas	Pos. No. N. Index Pos.	N. Cod. Code No. Nr. Code Code Nr N. Cod.	DENOMINAZIONE	NAME	DESIGNATION	BESCHREIBUNG	DENOMINACION	Q.tà Q.ty Q.té M.gs C.ñd	Validità Validky Validé Gültig Validez
★	1	8000 79348	Telaio	Frame	Chassis	Rahmen	Bastidor	1	
☆	1	8000 78658	Telaio	Frame	Chassis	Rahmen	Bastidor	1	
	2	1513070-01	Cuscinetto	Bearing	Roulement	Lager	Cojinete	2	
	3	8000 73140	Perno	Pin	Pivot	Bolzen	Perno	2	
	4	8000 69150	Piastrina	Plate	Plaquette	Plättchen	Placa	1	
	5	62N1 15507	Rosetta	Washer	Rondelle	Scheibe	Arandela	2	
	6	8AA0 72564	Poggiapiedi Dx.	R.H. foot rest support	Support repose pied D.	R., Fussraster	Prisioneros derecn. compl.	1	
	7	80A0 72564	Poggiapiedi Sx.	L.H. foot rest support	Support repose pied G.	L., Fussraster	Prisioneros compl.	1	
	8	64N1 20068	Copiglia	Split pin	Goupille	Splint	Clavija	2	
	9	8000 73341	Molla	Spring	Ressort	Feder	Resorte	2	
	10	8000 43928	Dado	Nut	Ecrou	Mutter	Tuerca	4	
	11	8000 66111	Piastra motore	Motor plate	Plaquette moteur	Motorplättchen	Placa motor	2	
	12	8000 33373	Rivetto	Rivet	Rivet	Niet	Remache	2	
	13	8000 80277	Vite	Screw	Vis	Schraube	Tornillo	4	
	14	8000 62796	Vite	Screw	Vis	Schraube	Tornillo	2	
	15	8C00 69112	Vite	Screw	Vis	Schraube	Tornillo	1	
	16	8000 43928	Dado	Nut	Ecrou	Mutter	Tuerca	2	
	17	8000 69111	Vite	Screw	Vis	Schraube	Tornillo	1	
★	18	8000 75800	Telaio posteriore	Rear frame side	Chassis arrière	Sattelbrücke	Cuadro posterior	1	
☆	18	8000 75801	Telaio posteriore	Rear frame side	Chassis arrière	Sattelbrücke	Cuadro posterior	1	
	19	8000 59433	Rullo	Roller	Aiguille	Rolle	Rodillo	2	
	20	8000 63312	Cuscinetto	Bearing	Roulement	Lager	Cojinete	4	
	21	8000 59434	Distanziale	Spacer	Entretoise	Distanzstück	Separador	2	
	22	8000 41922	Rivetto	Rivet	Rivet	Niet	Remache	2	
★	23	8000 43391	Serratura antifurto	Anti-left lock assy	Serrure anti-vol compl.	Sicherheitsschloss kpl.	Cerradura compl.	1	
★	24	8000 35531	Chiave grezza	Raw key	Clef primitive	Schlüssel	Llave	1	

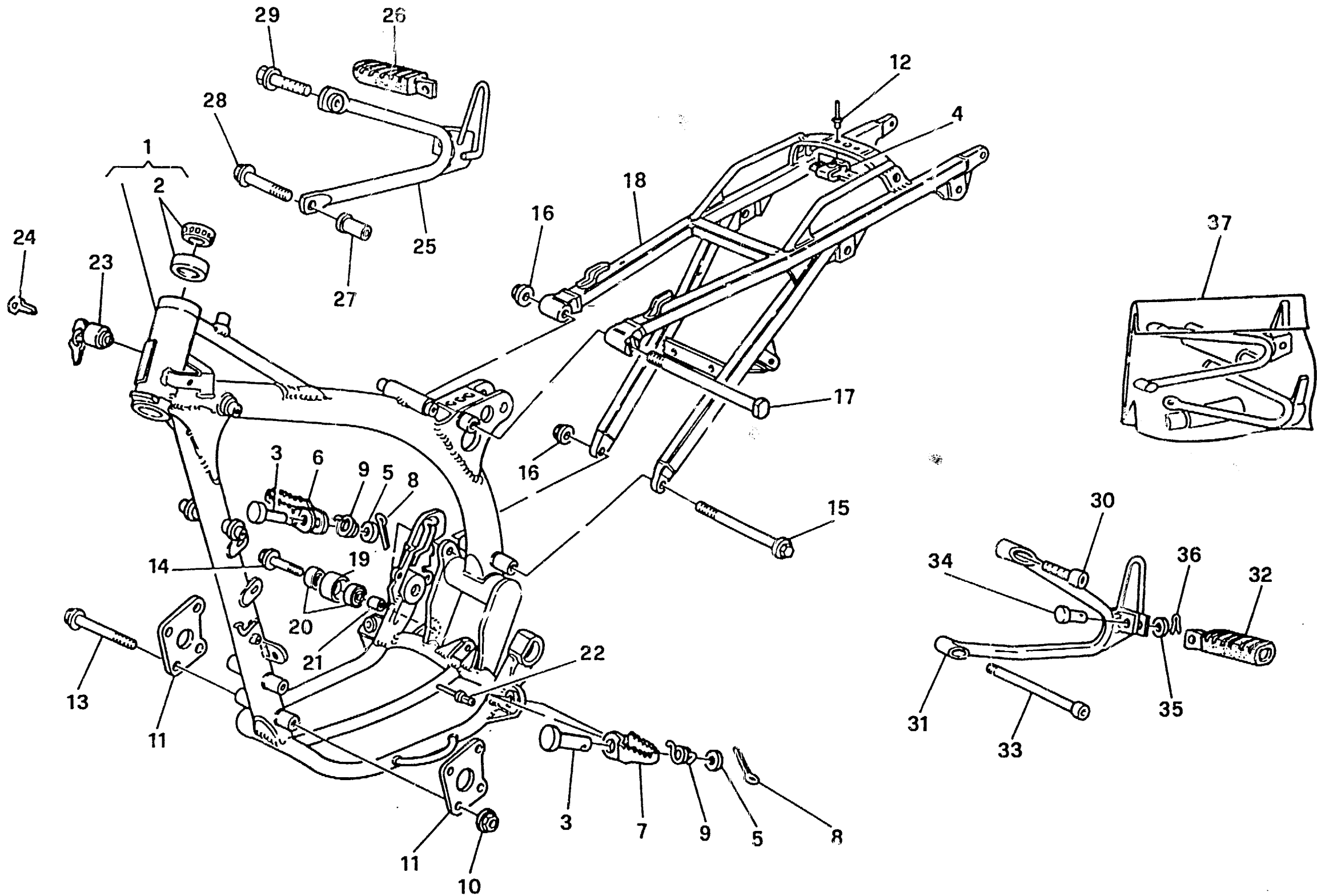



**TELAIO, PEDANE - FRAME, FOOT RESTS
CADRE, REPOSE PIEDS - RAHMEN, FUSSBRETT
BASTIDOR, REPOSAPIES**

TAVOLA
DRAWING
TABLE
BILD
TABLA

12

**TE - TC
610 / 95**

No. a No. es Notes /Aarke Notas	Pos. No. N. Index Pos.	N. Cod. Code No. Nr. Code Code Nr N. Cod.	DENOMINAZIONE	NAME	DESIGNATION	BESHREIBUNG	DENOMINACION	Q.tà Q.ty Q.te M.ge C.ad	Validità Validity Validité Gültig Validez
■	25	8000 67720	Supp. poggiapiedi Passegg. Dx.	Support	Support	Halterung	Soporte elástico	1	
■	26	8000 66652	Poggiapiedi passeggero Dx.	R.H. foot rest support	Support repose pied D.	R., Fussraster	Prisioneros derech. compl.	1	
■	27	8000 67724	Distanziale	Spacer	Entretoise	Distanzstück	Separador	1	
■	28	8A00 62797	Vite	Screw	Vis	Schraube	Tornillo	1	
■	29	8000 69056	Vite	Screw	Vis	Schraube	Tornillo	2	
■	30	60N10 2555	Vite	Screw	Vis	Schraube	Tornillo	1	
■	31	8000 78265	Supp. poggiapiedi passegg. Sx.	Support	Support	Halterung	Soporte elástico	1	
■	32	8000 66651	Poggiapiedi passeggero Sx.	L.H. foot rest support	Support repose pied G.	L., Fussraster	Prisioneros compl.	1	
■	33	8000 62727	Vite	Screw	Vis	Schraube	Tornillo	1	
■	34	8000 41459	Perno	Pin	Pivot	Bolzen	Perno	2	
■	35	62N1 15504	Rosetta piana	Washer	Rondelle	Scheibe	Arandela	2	
■	36	64N1 20048	Copiglia	Split pin	Goupille	Splint	Clavija	2	
■	37	8000 78447	Kit poggiapiedi passeggero	L.H. foot rest support kit	Gr. support repose pied G.	L., Fussraster Gruppe	Kit prisioneros compl.	1	

■ = A richiesta (TE) ■ = Upon request (TE) ■ = Sur demande (TE) ■ = Auf Anfrage (TE) ■ = Bajo pedido (TE)
 ★ = Modello TE ★ = TE model ★ = Modèle TE ★ = Modell TE ★ = Modelo TE
 ☆ = Modello TC ☆ = TC modell ☆ = Modèle TC ☆ = Modell TC ☆ = Modelo TC

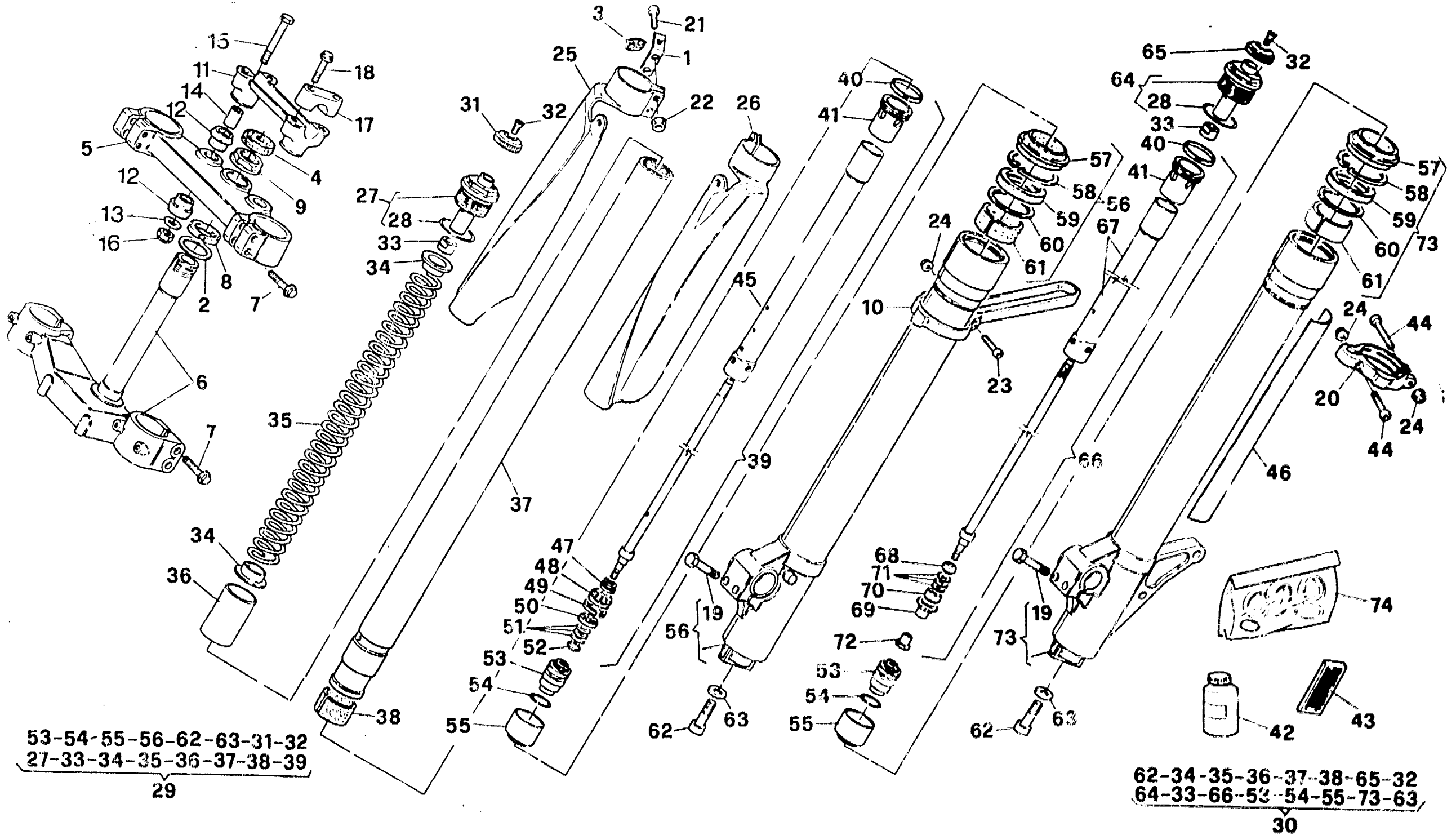

53-54-55-56-62-63-31-32
27-33-34-35-36-37-38-39
29

62-34-35-36-37-38-65-32
64-33-66-53-54-55-73-63
30



SOSPENSIONE ANTERIORE - FRONT FORK ASSEMBLY
SUSPENSION AVANT - VORDERTELESKOPGABEL
SUSPENSION DELANTERA

TAVOLA
DRAWING
TABLE
BILD
TABLA

13

TE - TC
610 / 95

Note Notes Notas	Pos. No. Indez Pos.	N. Cod. Code No. Nr. Code Code Nr N. Cod.	DENOMINAZIONE	NAME	DESIGNATION	BESCHREIBUNG	DENOMINACION	Q.tà Q.ty Q.ta M.ge C.ad	Validità Validky Validné Gültig Valdez
★	1	8000 80711	Piastrina	Plate	Plaquette	Plättchen	Placa	1	
	2	8A00 65503	Rosetta piana	Washer	Rondelle	Scheibe	Arandela	2	
★	3	8000 61068	Molletta di tenuta	Spring	Ressort	Feder	Resorte	1	
	4	8000 78756	Tappo	Plug	Bouchon	Verschluss	Tapón	1	
	5	3000 69040	Testa di sterzo	Steering head	Tête direction	Lenkkopf	Cabezal de dirección	1	
	6	8000 69041	Base di sterzo con perno	Steering crown with pin	Socle de direction avec pivot	Gabelbrücke mit Bolzen	Base de dirección con perno	1	
	7	8000 62796	Vite	Screw	Vis	Schraube	Tomillo	8	
	8	8000 69345	Ghiera registro cuscinetti	Ring nut	Embout	Nutmutter	Virola	1	
	9	8000 69315	Dado	Nut	Ecrou	Mutter	Tuerca	1	
	10	8000 79624	Anello	Ring	Bague	Ring	Anillo	1	
	11	8000 73141	Mozzetto inferiore	Hub	Moyeau	Radnabe	Cubo	1	
	12	8000 60233	Gommino	Rubber pad	Pièce caoutchouc	Gummistück	Junta de goma	4	
	13	8000 60234	Rosetta piana	Washer	Rondelle	Scheibe	Arandela	2	
	14	8000 53155	Distanziale	Spacer	Entretoise	Distanzstück	Separador	2	
	15	60N10 1219	Vite	Screw	Vis	Schraube	Tomillo	2	
	16	8000 61314	Dado	Nut	Ecrou	Mutter	Tuerca	2	
	17	8000 68516	Mozzetto superiore	Hub	Moyeau	Radnabe	Cubo	2	
	18	8000 62733	Vite	Screw	Vis	Schraube	Tomillo	4	
	19	8000 62729	Vite	Screw	Vis	Schraube	Tomillo	4	
★	20	8000 79623	Anello	Ring	Bague	Ring	Anillo	1	
☆	21	8000 79625	Anello	Ring	Bague	Ring	Anillo	1	
	21	8000 67937	Vite	Screw	Vis	Schraube	Tomillo	4	
	22	8000 56443	Dado	Nut	Ecrou	Mutter	Tuerca	4	
	23	60N40 2489	Vite	Screw	Vis	Schraube	Tomillo	1	
	24	61N4 15192	Dado	Nut	Ecrou	Mutter	Tuerca	3	
	25	8000 79532	Protezione steli Dx.	Guard R.H.	Protection G.	Schutz R.	Protección der.	1	
	26	8000 79531	Protezione steli Sx.	Guard L.H.	Protection D.	Schutz L.	Protección izq.	1	

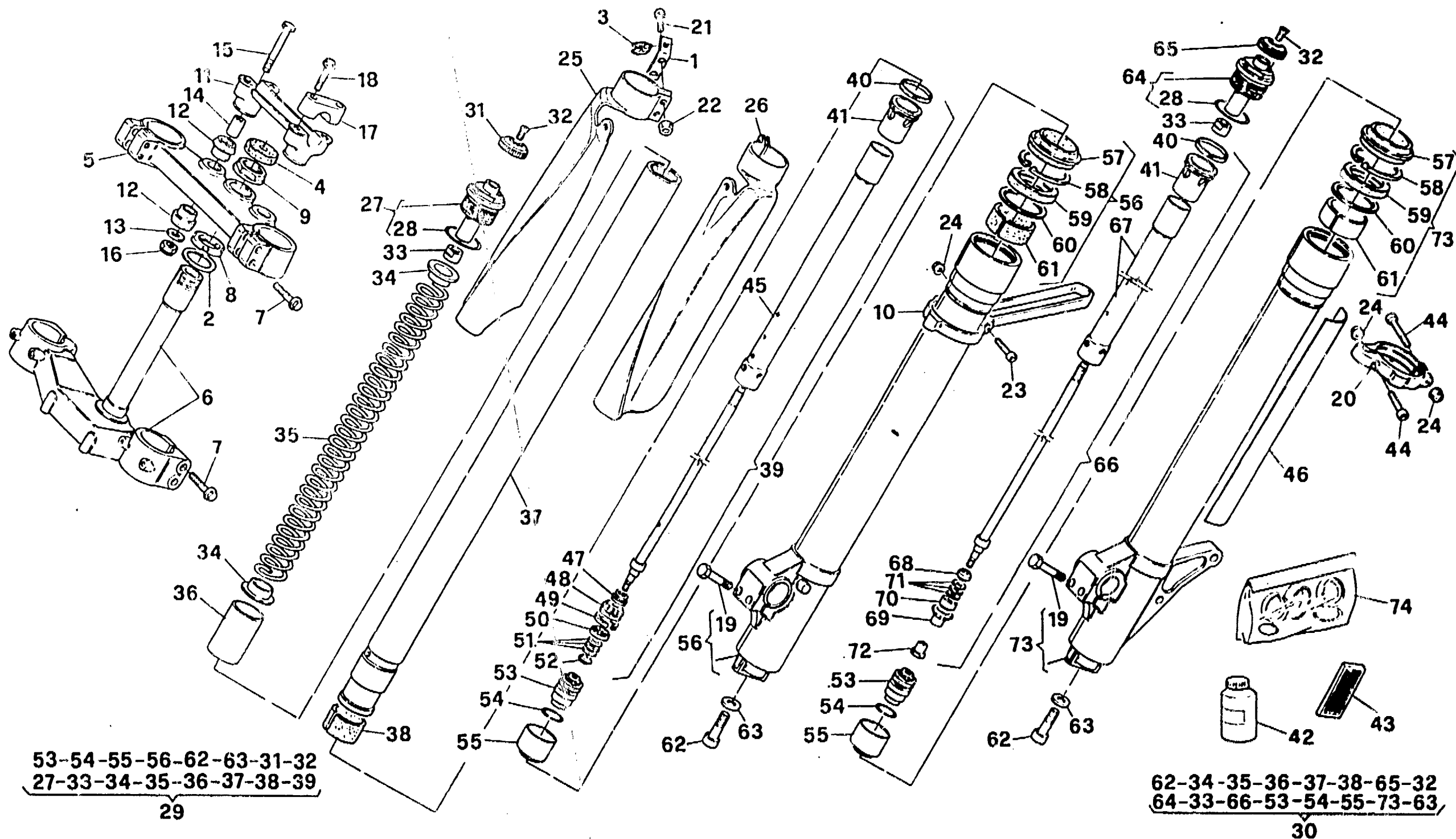

53-54-55-56-62-63-31-32
27-33-34-35-36-37-38-39
29

62-34-35-36-37-38-65-32
64-33-66-53-54-55-73-63
30



SOSPENSIONE ANTERIORE - FRONT FORK ASSEMBLY
SUSPENSION AVANT - VORDERTELESKOPGABEL
SUSPENSION DELANTERA

TAVOLA
DRAWING
TABLE
BILD
TABLA

13

TE - TC
610 / 95

Note Notes Notas	Pos. No. Index Pos.	N. Cod. Code No. Nr. Code Code Nr N. Cod.	DENOMINAZIONE	NAME	DESIGNATION	BESHREIBUNG	DENOMINACION	Q.tà Q.ty Q.té M.ge C.ad	Validità Validity Validité Gültig Validez
	27	8000 81190	Tappo Dx.	R.H. Plug	Bouchon D.	Verschluss R.	Tapón der.	1	
	28	8000 70324	Anello OR	O-Ring	Bague OR	O-Ring	Anillo OR	2	
	29	8000 79535	Gamba Dx. compl.	R.H. fork leg assy	Fourche complete D.	Telegabel Kpl. R.	Horquilla derech. compl.	1	
	30	8000 79534	Gamba Sx. compl.	L.H. fork leg assy	Fourche compl. G.	Telegabel, Kpl. L.	Horquill izrda. compl.	1	
	31	8000 81192	Pomello Dx.	R.H. Knob	PoignéeD.	Knopf R.	Pomo der.	1	
	32	8000 81194	Vite	Screw	Vis	Schraube	Tornillo	2	
	33	8000 81174	Dado	Nut	Ecrou	Mutter	Tuerca	2	
	34	8000 77373	Scodellino	Cup	Cuvette	Teller	Cubeta	4	
	35	8000 81173	Molla k=4,2	Spring	Ressort	Feder	Resorte	2	
▼	35	8000 80205	Molla k=4,4	Spring	Ressort	Feder	Resorte	2	
▼	35	8000 80206	Molla k=4,0	Spring	Ressort	Feder	Resorte	2	
	36	8000 81171	Tubetto	Pipe	Tuyau	Rohr	Tube	2	
	37	8000 81170	Tube	Pipe	Tuyau	Rohr	Tube	2	
	38	8000 70322	Bussola	Bushing	Douille	Buchse	Manguito	2	
	39	8000 81176	Gruppo estensione	Extension set	Groupe extension	Dehnungsatz	Grupo extensión	1	
	40	8000 81168	Segmento	Circlip	Segment	Colbenring	Segmento	2	
	41	8000 81167	Bussola	Bushing	Douille	Buchse	Manguito	2	
▼	42	8000 80260	Olio forcella	Front fork oil	Huile fourche avant	Öl für die Vordergabel	Aceite horquilladelantera	1	
	43	8000 45436	Catadiottro (D)	Reflector (D)	Catadioptrique (D)	Rückstrahler (D)	Catafaros (D)	2	
	44	8000 67997	Vite	Screw	Vis	Schraube	Tornillo	2	
	45	8000 81188	Tube Dx.	R.H. pipe	Tuyau D.	Rohr R.	Tube der.	1	
	46	8000 80315	Decal.	Trim	Décal.	Abziehbild	Calcomania	2	
	47	8000 81166	Molla	Spring	Ressort	Feder	Resorte	1	
	48	8000 81186	Pistone Dx.	R.H. piston	Piston D.	Kolbe R.	Pistón der.	1	
	49	8000 61136	Segmento	Circlip	Segment	Colbenring	Segmento	2	
	50	8000 81182	Spillo Dx.	R.H. needle	Pointeau D.	Nadel R.	Pasador der.	1	

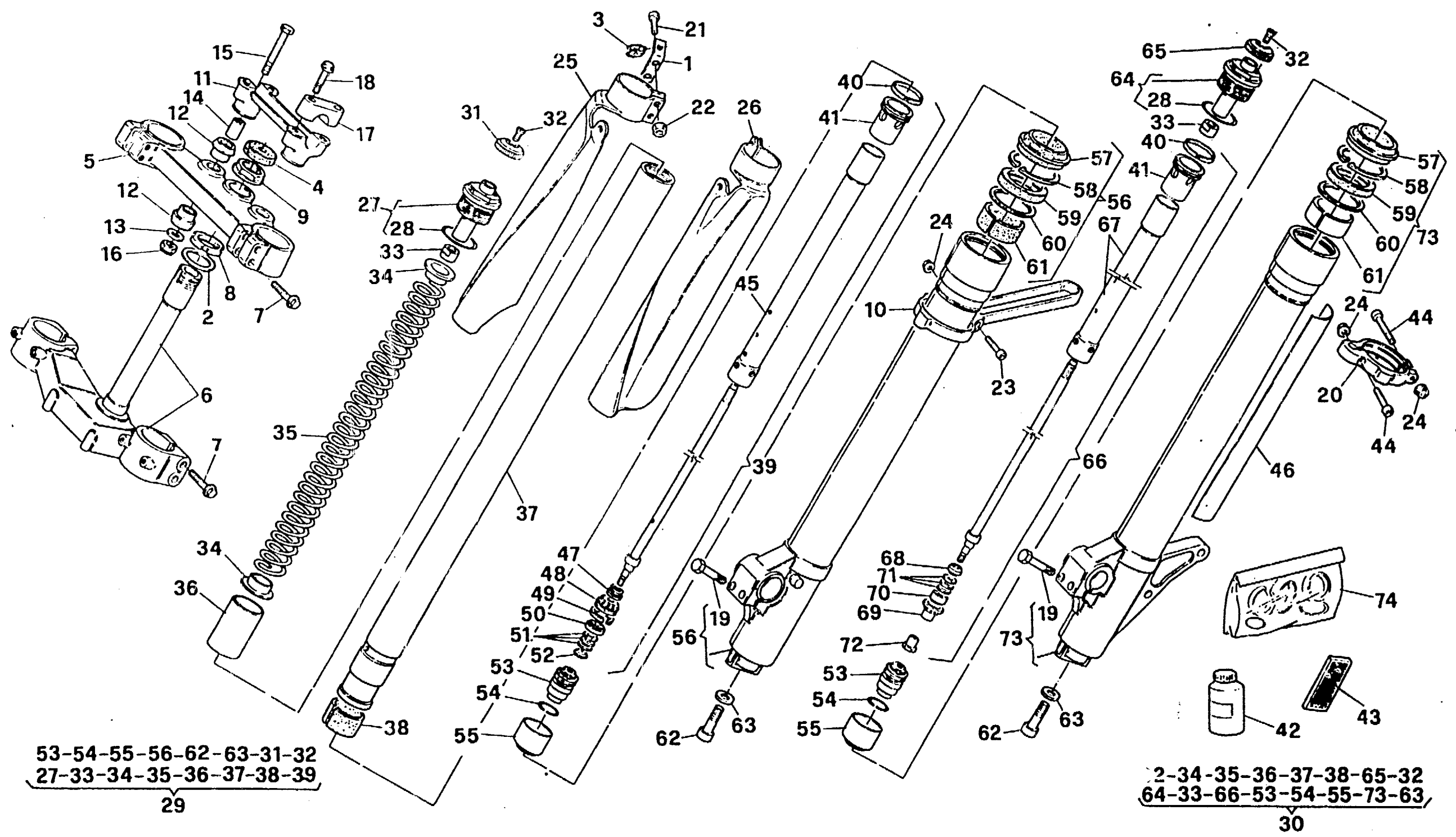

53-54-55-56-62-63-31-32
27-33-34-35-36-37-38-39
29

2-34-35-36-37-38-65-32
64-33-66-53-54-55-73-63
42 43 74
30



SOSPENSIONE ANTERIORE - FRONT FORK ASSEMBLY
 SUSPENSION AVANT - VORDERTELESKOPGABEL
 SUSPENSION DELANTERA

TAVOLA
 DRAWING
 TABLE
 BILD
 TABLA

13

TE - TC
 610 / 95

Note Notes Marka Notas	Pos. No. Index Pos.	N. Cod. Code No. Nr. Code Code Nr N. Cod.	DENOMINAZIONE	NAME	DESIGNATION	BESHREIBUNG	DENOMINACION	Q.tà Q.ty Q.té M.ge C.au	Validità Validty Valdké Gultig Valdez
	51	8000 81181	Lamella	Plate	Lamelle	Plättchen	Laminilla	1	
	52	8000 81178	Dado Dx.	R.H. nut	Ecrou D.	Mutter R.	Tuerca der.	1	
	53	8000 81165	Valvola	Valve	Soupape	Ventil	Válvula	2	
	54	8000 81164	Anello OR	O-Ring	Bague OR	O-Ring	Anillo OR	2	
	55	8000 81163	Adattatore	Adapter	Adapter	Adapter	Adapter	2	
	56	8000 81844	Scorrevole Dx. compl.	R.H. slider assy	Montant D. compl.	Bein, Kpl. R.	Deslizable der. compl.	1	
	57	8000 81162	Raschiapolvere	Dust scraper	Racloir poudre	Pulverabschaber	Rascador de polvo	2	
	58	8000 81161	Anello di fermo	Stop ring	Bague d'arrêt	Haltering	Anillo de retención	2	
	59	8000 70330	Anello di tenuta	Seal ring	Bague de retenue	Dichtring	Anillo de retención	2	
	60	8000 81159	Scodellino	Cup	Cuvette	Teller	Cubeta	2	
	61	8000 70328	Bussola	Bushing	Couille	Buchse	Manguito	2	
	62	8000 46510	Vite	Screw	Vis	Schraube	Tomillo	2	
	63	8000 46511	Rosetta	Washer	Rondelle	Scheibe	Arandola	2	
	64	8000 81191	Tappo Sx.	L.H. Plug	Bouchon G.	Verschluss L.	Tapón izrda.	1	
	65	8000 81193	Pomello Sx.	L.H. Knob	Poignée G.	Knopf L.	Pomo izrda.	1	
	66	8000 81177	Gruppo compressione	Compression set	Groupe compression	Kompressionsatz	Grupo compresión	1	
	67	8000 81189	Tubo Sx.	L.H. pipe	Tuyau G.	Rohr L.	Tubo izrda.	1	
	68	8000 74324	Scodellino	Cup	Cuvette	Teller	Cubeta	2	
	69	8000 81185	Pistone Sx.	L.H. piston	Piston G.	Kolbe L.	Pistón izrda.	1	
	70	8000 81183	Spillo Sx.	L.H. needle	Poinneau G.	Nadel L.	Pasador izrda.	1	
	71	8000 81180	Lamella	Plate	Lamelle	Plättchen	Laminilla	1	
	72	8000 74309	Dado Sx.	L.H. nut	Ecrou G.	Mutter L.	Tuerca izrda.	1	
	73	8000 81845	Scorrevole Sx. compl.	L.H. slider assy	Montant G. compl.	Bein, Kpl. L.	Deslizable izrda. compl.	1	
	74	8000 81156	Gruppo guarnizioni	Gasket set	Groupe garnitures	Dichtungssatz	Grupo juntas	1	
			▼ = A richiesta ★ = Modello TE ☆ = Modello TC	▼ = Upon request ★ = TE model ☆ = TC modell	▼ = Sur demande ★ = Modèle TE ☆ = Modèle TC	▼ = Auf Anfrage ★ = Modell TE ☆ = Modell TC	▼ = Bajo pedido ★ = Modelo TE ☆ = Modelo TC		

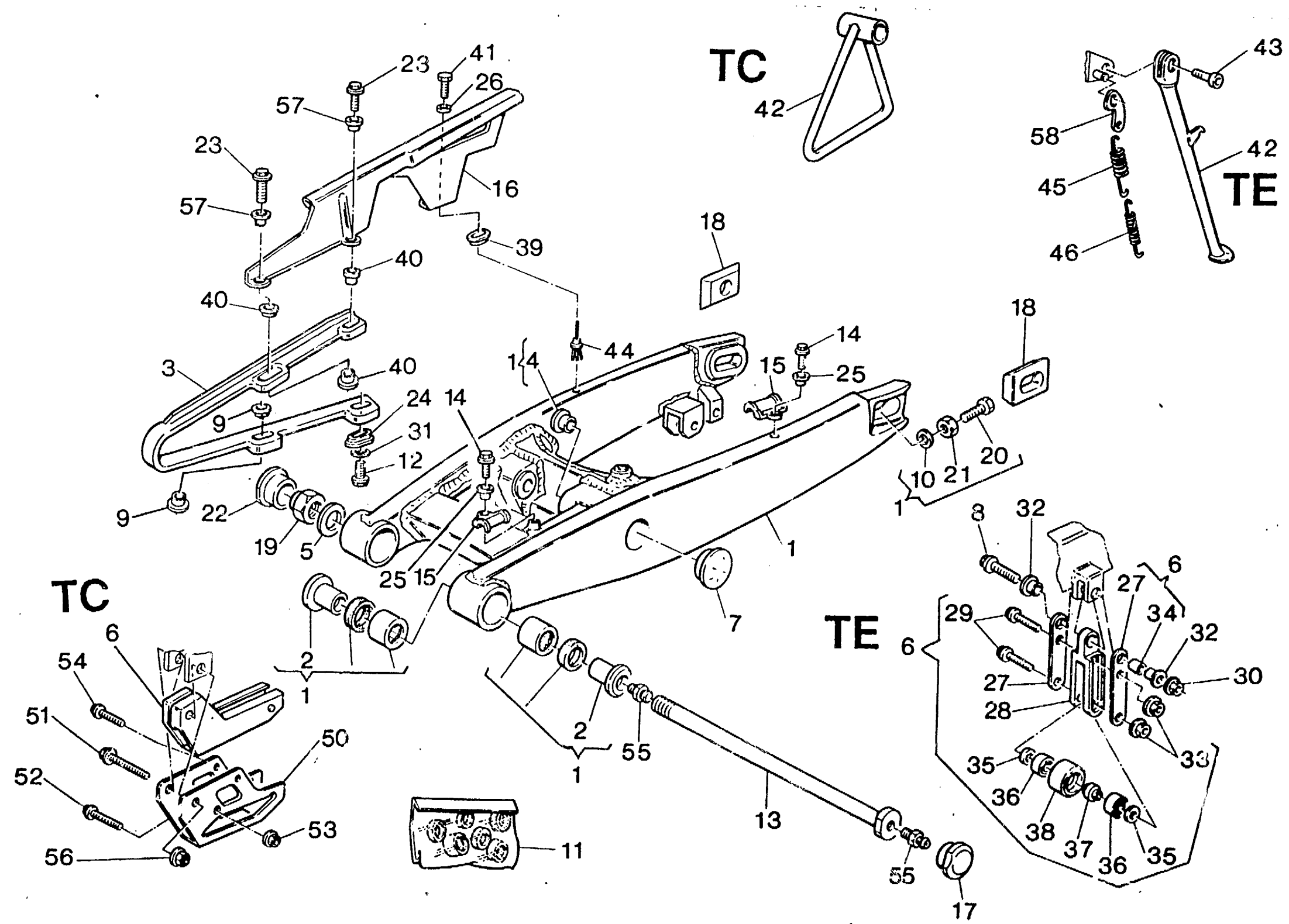



**FORCELLONE - SWING ARM
FOURCHE - GABEL
HORQUILLA**

TAVOLA
DRAWING
TABLE
BILD
TABLA

14

**TE - TC
610 / 95**

Note Notes Notas	Pos. No. Index Pos.	N. Cod. Code No. Nr. Code Code Nr N. Cod.	DENOMINAZIONE	NAME	DESIGNATION	BESCHREIBUNG	DENOMINACION	Q.tà Q.ty Q.ty M. qe C. ad	Validità Validity Validité Gültig Validez
	1	8000 76263	Forcellone completo	Compl. fork	Fourche complete	Gabel, Kpl.	Horquilla compl.	1	
	2	8000 66196	Bussola	Bushing	Douille	Buchse	Manguito	4	
	3	8000 72884	Pattino catena	Chain slider	Glissière	Gleitbahn	Plato cadena	1	
	4	8B00 42029	Bussola	Bushing	Douille	Buchse	Manguito	4	
	5	62N1 15524	Rosetta piana	Washer	Rondelle	Scheibe	Arandela	1	
★	6	8000 72873	Guidacatena	Chain guide	Guide-chaine	Kettenführung	Guía-cadena	1	
☆	6	8000 72868	Guidacatena	Chain guide	Guide-chaine	Kettenführung	Guía-cadena	1	
	7	80A0 74383	Tappo	Plug	Bouchon	Verschluss	Tapón	2	
★	8	8000 62795	Vite	Screw	Vis	Schraube	Tomillo	1	
	9	8000 75166	Scodellino	Cup	Cuvette	Teller	Cubeta	2	
	10	80000 8536	Rosetta	Washer	Rondelle	Scheibe	Arandela	2	
	11	8000 67373	Kit cuscinetti e anelli di tenuta	Bearing and seal ring kit	Gr. roulemen.et bague de reten.	Kugellager und Dichtring grupps	Kit cojinele y anillo de retención	1	
★	12	8000 67997	Vite	Screw	Vis	Schraube	Tomillo	2	
☆	12	8000 67997	Vite	Screw	Vis	Schraube	Tomillo	4	
	13	8000 64591	Perno forcellone	Fork pin	Pivot fourche	Gabelbolzen	Perno horquilla	1	
	14	8000 20536	Vite	Screw	Vis	Schraube	Tomillo	2	
	15	80A0 73456	Guidacavo	Cable guide	Guide câble	Kabelführung	Guía-cable	2	
★	16	80A0 73426	Copricatena	Chain guard	Carter de chaine	Kettenkasten	Cubre-cadena	1	
	17	80A0 66202	Tappo	Plug	Bouchon	Verschluss	Tapón	1	
	18	8000 71624	Tendicatena lato dado	Chain adjuster - nut side	Tendeur de chaine côtés ecrou	Kettenspanner Mutterseite	Tensor de cadena lato tuerca	1	
	18	8000 71625	Tendicatena lato perno	Chain adjuster - pin side	Tendeur de chaine côtés pivot	Kettenspanner bolzenseite	Tensor de cadena lato perno	1	
	19	1511249-01	Dado	Nut	Ecrou	Mutter	Tuerca	1	
	20	8C00 61121	Vite	Screw	Vis	Schraube	Tomillo	2	
	21	8000 17810	Dado	Nut	Ecrou	Mutter	Tuerca	2	
	22	80A0 67448	Tappo	Plug	Bouchon	Verschluss	Tapón	1	
★	23	8A00 67997	Vite	Screw	Vis	Schraube	Tomillo	2	

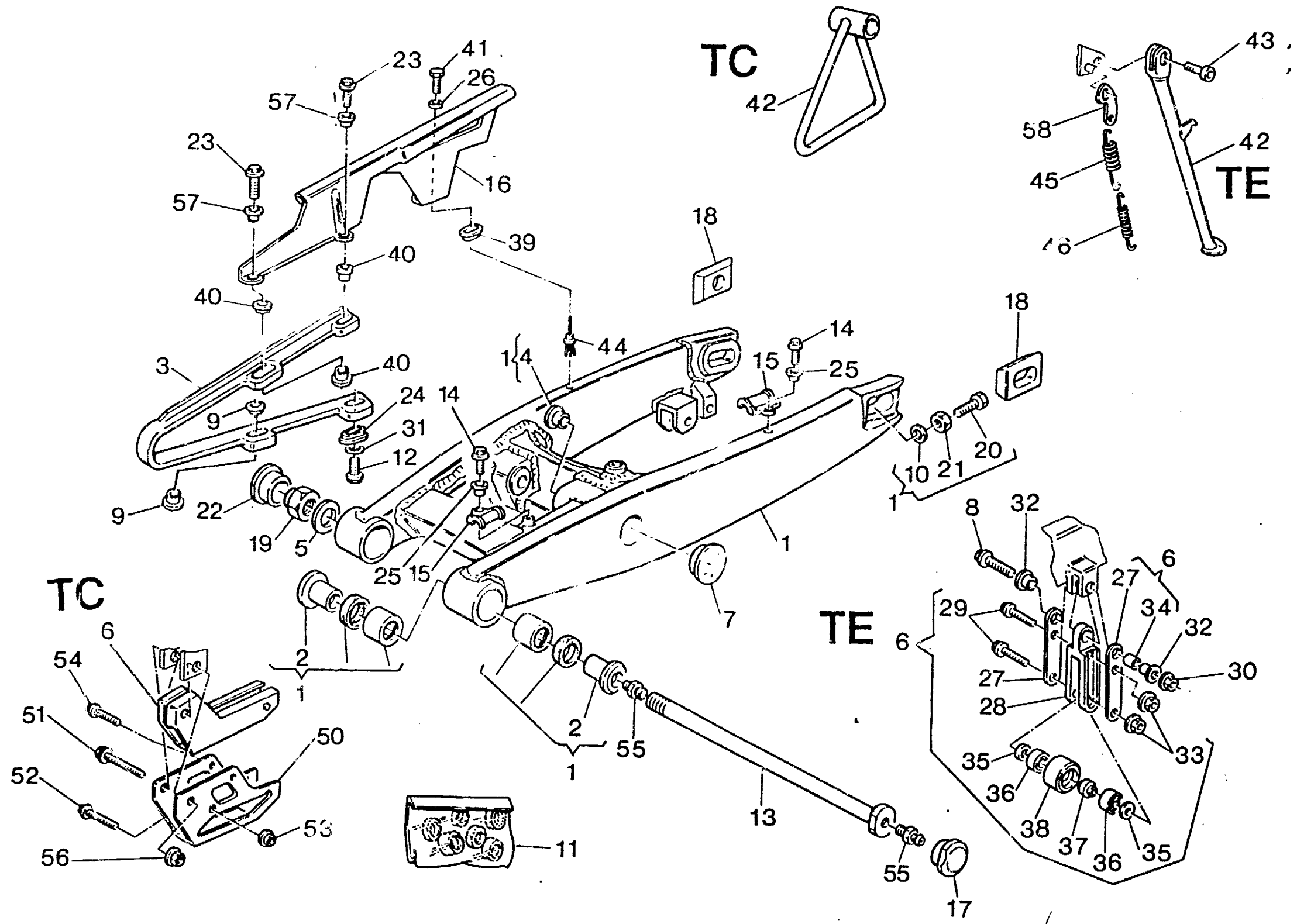



**FORCELLONE - SWING ARM
FOURCHE - GABEL
HORQUILLA**

**TAVOLA
DRAWING
TABLE
BILD
TABLA**

14

**TE - TC
610 / 95**

Note Notes Marka Notas	Pos. No. N. Index Pos.	N. Cod. Code No. Nr. Code Code Nr N. Cod.	DENOMINAZIONE	NAME	DESIGNATION	BESHREIBUNG	DENOMINACION	Q.ta Q.ty Q.ite M.ge C.ad	Valdka Valdity Valdite Gultig Valdez
	24	8000 59289	Scodellino	Cup	Cuvette	Teller	Cubeta	3	
	25	8000 69282	Bussola	Bushing	Douille	Buchse	Manguito	2	
★	26	8000 36137	Rosetta	Washer	Rondelle	Scheibe	Arandela	1	
★	27	8000 72875	Lamiera guidacatena	Chain guide	Guide-chaine	Kettenführung	Guía-cadena	2	
★	28	8000 72874	Piastra d'attacco	Plate	Plaque	Platte	Placa	1	
★	29	8000 62731	Vite	Screw	Vis	Schraube	Tornillo	2	
★	30	8000 43928	Dado	Nut	Ecrou	Mutter	Tuerca	1	
	31	8000 36137	Rosetta	Washer	Rondelle	Scheibe	Arandela	2	
★	32	8A00 66661	Bussola	Bushing	Douille	Buchse	Manguito	1	
★	33	8000 44240	Dado	Nut	Ecrou	Mutter	Tuerca	2	
★	34	1515506-01	Bussola elastica	Bushing	Douille	Buchse	Manguito	1	
★	35	8000 45495	Rosetta di spallamento	Washer	Rondelle	Scheibe	Arandela	2	
★	36	8000 63312	Cuscinetto	Bearing	Roulement	Kugellager	Cojinete	2	
★	37	8000 65412	Distanziale	Spacer	Entretoise	Distanzstück	Separador	1	
★	38	8000 65411	Rullo guidacatena	Roller	Aiguille	Rolle	Rodillo	1	
★	39	8000 59289	Scodellino	Cup	Cuvette	Teller	Cubeta	1	
★	40	8000 75166	Scodellino	Cup	Cuvette	Teller	Cubeta	3	
★	41	8000 20536	Vite	Screw	Vis	Schraube	Tornillo	1	
★	42	8000 73877	Gamba laterale	Side stand	Bequille lat.	Seitenständer	Horquilla lateral	1	
☆	42	8000 74016	Gamba laterale	Side stand	Bequille lat.	Seitenständer	Horquilla lateral	1	
★	43	8000 75957	Vite	Screw	Vis	Schraube	Tornillo	1	
☆	44	8000 75160	Rivetto	Rivet	Rivet	Niet	Remache	1	
★	45	8000 62675	Molla esterna	Spring	Ressort	Feder	Resorte	1	
★	46	8000 62676	Molla interna	Spring	Ressort	Feder	Resorte	1	
☆	50	8000 72869	Staffa	Bracket	Etrier	Buegel	Brida	1	
☆	51	8A00 69056	Vite	Screw	Vis	Schraube	Tornillo	1	

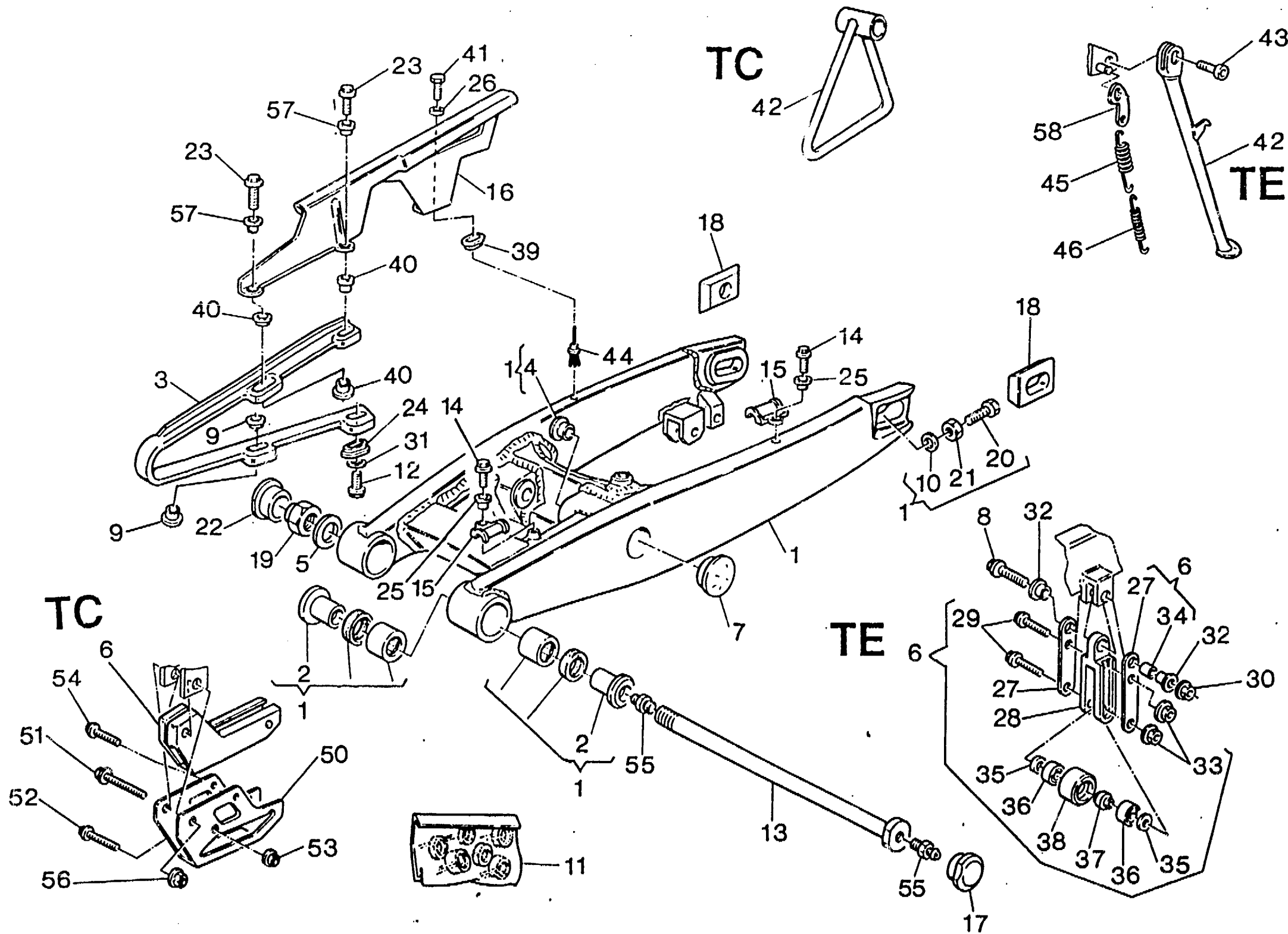



FORCELLONE - SWING ARM
FOURCHE - GABEL
HORQUILLA

TAVOLA
DRAWING
TABLE
BILD
TABLA

14

TE - TC
610 / 95

Note Notes Marka Notas	Pos. No. N. Index Pos.	N. Cod. Code No. Nr. Code Code Nr N. Cod.	DENOMINAZIONE	NAME	DESIGNATION	BESHREIBUNG	DENOMINACION	Q.tà Q.ty Q.té M.ge C.ad	Validità Validty Validté Gültig Validez
☆	52	8000 62731	Vite	Screw	Vis	Schraube	Tornillo	1	
☆	53	8000 44240	Dado	Nut	Ecrou	Mutter	Tuerca	1	
☆	54	8000 62725	Vite	Screw	Vis	Schraube	Tornillo	1	
	55	80000 1412	Ingrassatore	Lubricator	Graisseur	Schmierbüchse	Lubricador	2	
☆	56	8000 43928	Dado	Nut	Ecrou	Mutter	Tuerca	1	
★	57	8A00 69282	Distanziale	Spacer	Entretoise	Distanzstück	Separador	2	
★	58	8000 25647	Piastrina	Plate	Plaquette	Plättchen	Placa	1	
			★ = Modello TE ☆ = Modello TC	★ = TE model ☆ = TC modell	★ = Modèle TE ☆ = Modèle TC	★ = Modell TE ☆ = Modell TC	★ = Modelo TE ☆ = Modelo TC		

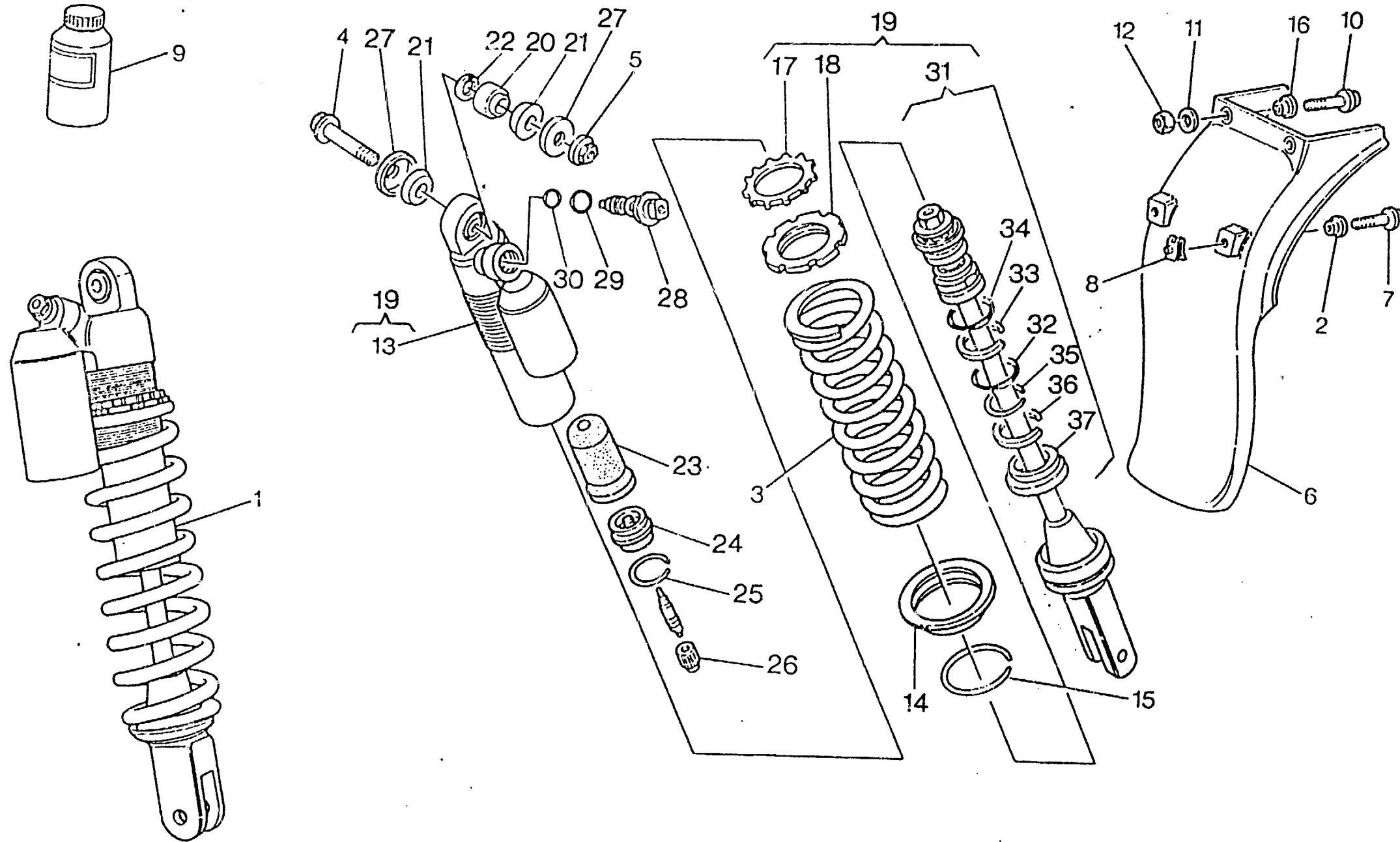



AMMORTIZZATORE POSTERIORE - REAR SUSPENSION
SUSPENSION ARRIÈRE - HINTERHAUFHANGUNG
SUSPENSION TRASERA

TAVOLA
DRAWING
TABLE
BILD
TABLA

15

TE - TC
610 / 95

Note Notes Notas	Pos. No. Index Pos.	N. Cod. Code No. Nr. Code Code Nr N. Cod.	DENOMINAZIONE	NAME	DESIGNATION	BESHREIBUNG	DENOMINACION	Q.tà Q.ty Q.tis M.ge C.ad	Validità Validity Validez Gültig Validez
	1	8000 79272	Ammortizzatore completo	Shock-absorber	Ammortisseur	Stossdämpfer	Amortigüador	1	
	2	8000 69429	Bussola	Bushing	Douille	Buchse	Manguito	2	
	3	8000 70404	Molla k=5,6	Spring	Ressort	Feder	Resorte	1	
▼	3	8000 71440	Molla k=5,4	Spring	Ressort	Feder	Resorte	1	
▼	3	8000 70398	Molla k=5,8	Spring	Ressort	Feder	Resorte	1	
	4	8A00 62797	Vite	Screw	Vis	Schraube	Tomillo	1	
	5	8000 42022	Dado	Nut	Ecrou	Mutter	Tuerca	1	
	6	80A0 70218	Protezione ammortizzatore	Guard	Protection	Schutz	Protección	1	
	7	8000 62727	Vite	Screw	Vis	Schraube	Tomillo	2	
	8	8000 46893	Dado a graffetta	Nut	Ecrou	Mutter	Tuerca	2	
▼	9	8000 80204	Olio ammortizzatore	Shock-absorber oil	Huile ammortisseur	Öl für Stossdämpfer	Aceite amortigüador	1	
	10	8A00 67545	Vite	Screw	Vis	Schraube	Tomillo	2	
	11	8000 56359	Rosetta piana	Washer	Rondelle	Scheibe	Arandela	2	
	12	8000 44240	Dado	Nut	Ecrou	Mutter	Tuerca	2	
	13	8000 80715	Corpo ammortizzatore	Damper case	Corps ammortisseur	Stossdämpferkörper	Corpo amortigüador	1	
	14	8000 70401	Fondello	Bottom	Fond	Bodenscheibe	Casquillo	1	
	15	8000 70402	Anello seeger	Seeger ring	Bague seeger	Seeger ring	Anillo seeger	1	
	16	8000 72268	Distanziale	Spacer	Entretoise	Distanzstück	Separador	2	
	17	8000 73509	Ghiera	Ring nut	Embout	Nutmutter	Virola	1	
	18	8000 73504	Ghiera	Ring nut	Embout	Nutmutter	Virola	1	
	19	8000 80714	Ass. corpo ammortizzatore	Damper case assy	Corps ammortisseur compl.	Stossdämpferkörper, Kpl.	Corpo amortigüador compl.	1	
	20	8000 73547	Snodo sferico	Ball joint	Joint a rotule	Kugelgelenk	Articulación esférica	1	
	21	8000 73548	Anello di tenuta	Seal ring	Bague de retenue	Dichtring	Anillo de retención	2	
	22	8000 73549	Anello elastico	Split ring	Anneau ressort	Sprengring	Anillo elástico	1	
	23	8000 73550	Cuffia di protezione	Boot	Poussière	Gummihaube	Gorro de protección en goma	1	
	24	8000 73552	Tappo	Plug	Bouchon	Verschluss	Tapón	1	

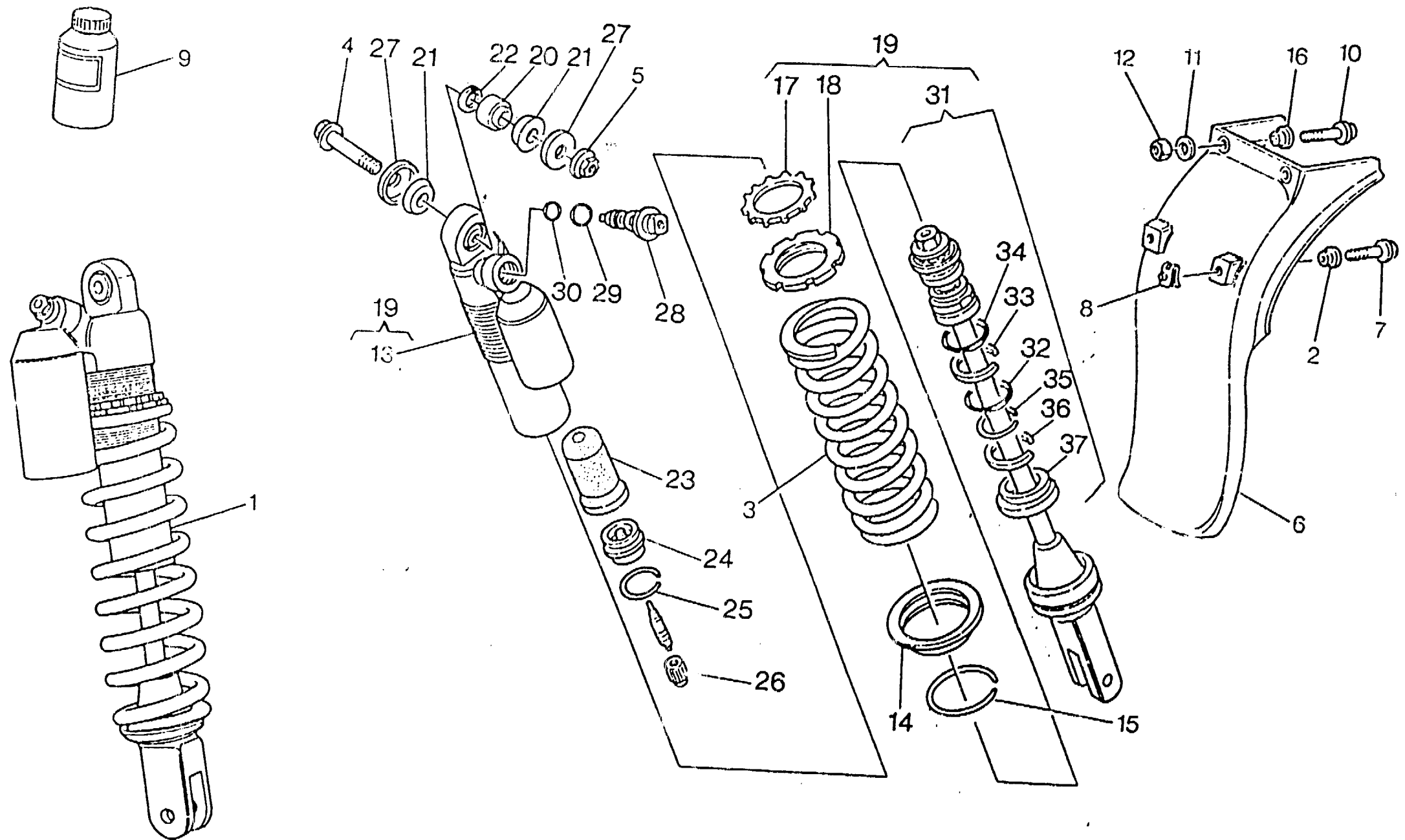



AMMORTIZZATORE POSTERIORE - REAR SUSPENSION
 SUSPENSION ARRIÈRE - HINTERHAUFHANGUNG
 SUSPENSION TRASERA

TAVOLA
 DRAWING
 TABLE
 BILD
 TABLA

15

TE - TC
 610 / 95

Nota Notes Marka Notas	Pos. No. N. Index Pos.	N. Cod. Code No. Nr. Code Code Nr N. Cod.	DENOMINAZIONE	NAME	DESIGNATION	BESCHREIBUNG	DENOMINACION	Q.tà Q.ty Q.té M.ge C.ad	Validità Validity Validité Gültig Validez
	25	8000 73553	Anello elastico	Split ring	Anneau ressort	Sprengring	Anillo elástico	1	
	26	8000 80705	Tappo	Plug	Bouchon	Verschluss	Tapón	1	
	27	8000 73555	Anello	Ring	Bague	Ring	Anillo	2	
	28	8000 80716	Tappo	Plug	Bouchon	Verschluss	Tapón	1	
	29	8000 73557	Anello OR	O-Ring	Bague OR	O-Ring	Anillo OR	1	
	30	8000 73558	Anello OR	O-Ring	Bague OR	O-Ring	Anillo OR	1	
	31	8000 80717	Ass. pistone	Complete piston	Piston complet	Kolbe, Kpl.	Pistón completo	1	
	32	8000 74972	Anello OR	O-Ring	Bague OR	O-Ring	Anillo OR	1	
	33	8000 74973	Anello	Ring	Bague	Ring	Anillo	1	
	34	8000 74974	Anello OR	O-Ring	Bague OR	O-Ring	Anillo OR	1	
	35	8000 74975	Anello elastico	Split ring	Anneau ressort	Sprengring	Anillo elástico	1	
	36	8000 74976	Anello elastico	Split ring	Anneau ressort	Sprengring	Anillo elástico	1	
	37	8000 74977	Anello elastico	Split ring	Anneau ressort	Sprengring	Anillo elástico	1	
			▼ = A richiesta	▼ = Upon request	▼ = Sur demande	▼ = Auf Anfrage	▼ = Bajo pedido		

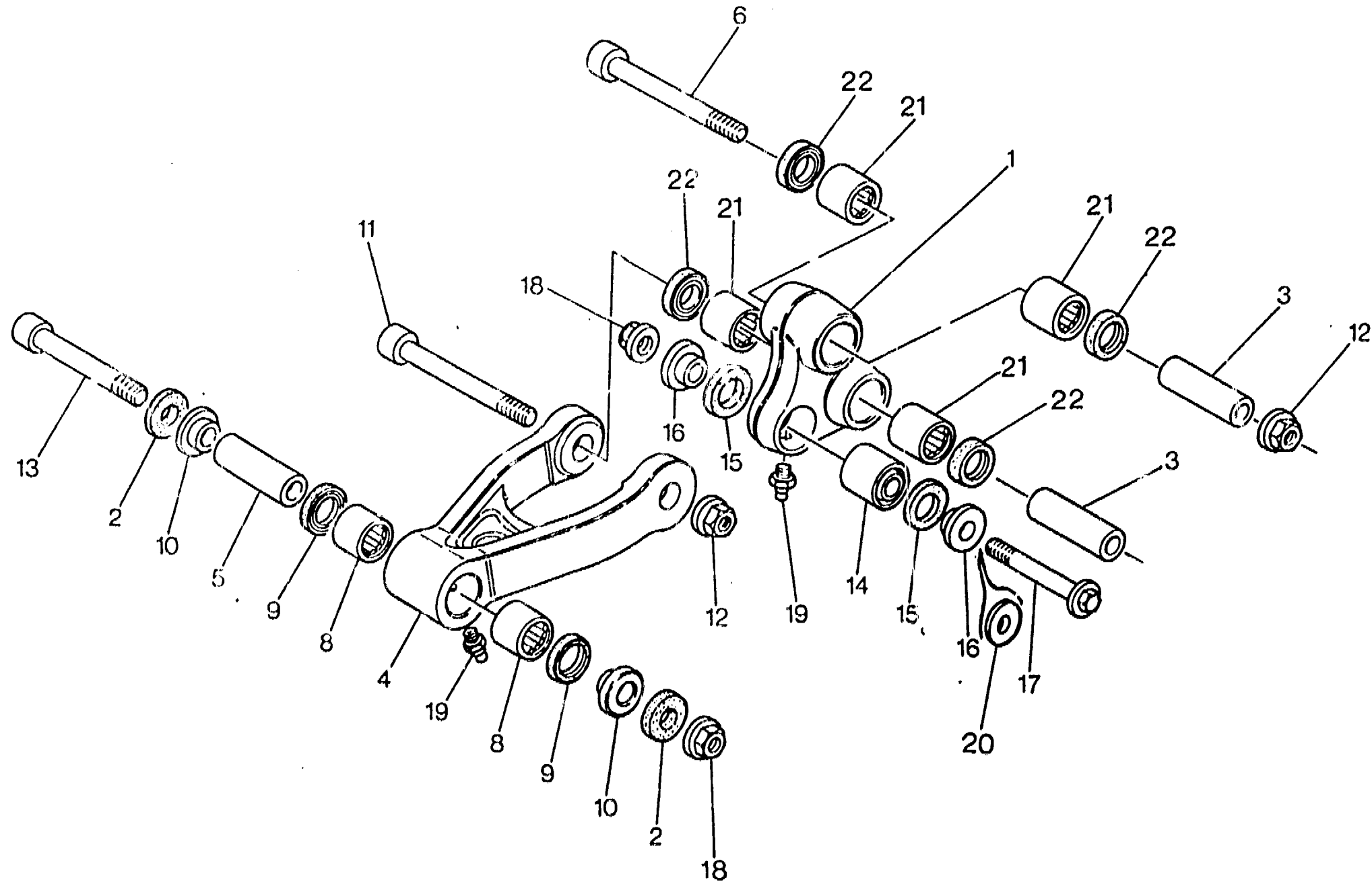



LEVERAGGI SOSPENSIONE POST. - REAR SUSPENSION LINKAGE
LEVIER SUSPENSION ARRIERE - HEBELWERK HINTERHAUFHANGUNG
PALANCA SUSPENSION TRASERA

TAVOLA
DRAWING
TABLE
BILD
TABLA

16

TE - TC
610 / 95

Note Notes Notas	Pos. No. N. Index Pos.	N. Cod. Code No. Nr. Code Code Nr N. Cod.	DENOMINAZIONE	NAME	DESIGNATION	BFSHREIBUNG	DENOMINACION	Q.tà Q.ty Q.ty M.ge C.ad	Valdka Valdky Valoké Gullig Valdez
	1	8000 75868	Tirante verticale	Tie rod	Tirant	Spannstange	Tirante	1	
	2	8000 73394	Anello di feltro	Feltseal	Bague en fetre	Filzring	Anillo de fieltro	4	
	3	8A00 75153	Spinotto	Gudgeon	Axe	Bolzen	Perno	1	
	4	8A00 69285	Tirante orizzontale	Tie rod	Tirant	Spannstange	Tirante	1	
	5	8000 59839	Spinotto	Gudgeon	Axe	Bolzen	Perno	1	
	6	8000 74372	Vite	Screw	Vis	Schraube	Tomillo	1	
	8	8000 38956	Cuscinetto	Bearing	Roulement	Lager	Cojinete	2	
	9	8000 38957	Guarnizione	Gasket	Garnitue	Dichtung	Junta	2	
	10	8B00 42029	Bussola	Bushing	Douille	Buchse	Manguito	4	
	11	8000 77413	Vite	Screw	Vis	Schraube	Tomillo	1	
	12	8000 42023	Dado	Nut	Ecrou	Mutter	Tuerca	2	
	13	8A00 69138	Vite	Screw	Vis	Schraube	Tomillo	1	
	14	8000 72168	Cuscinetto	Bearing	Roulement	Lager	Cojinete	1	
	15	8000 38767	Guarnizione	Gasket	Garnitue	Dichtung	Junta	2	
	16	1511333-02	Bussola	Bushing	Douille	Buchse	Manguito	2	
	17	8A00 62797	Vite	Screw	Vis	Schraube	Tomillo	1	
	18	8000 42022	Dado	Nut	Ecrou	Mutter	Tuerca	2	
	19	80000 1412	Ingrassatore	Lubricator	Graisneur	Schmierbüchse	Lubricador	2	
	21	8000 42781	Cuscinetto	Bearing	Roulement	Lager	Cojinete	4	
	22	8000 32065	Guarnizione	Gasket	Garnitue	Dichtung	Junta	4	

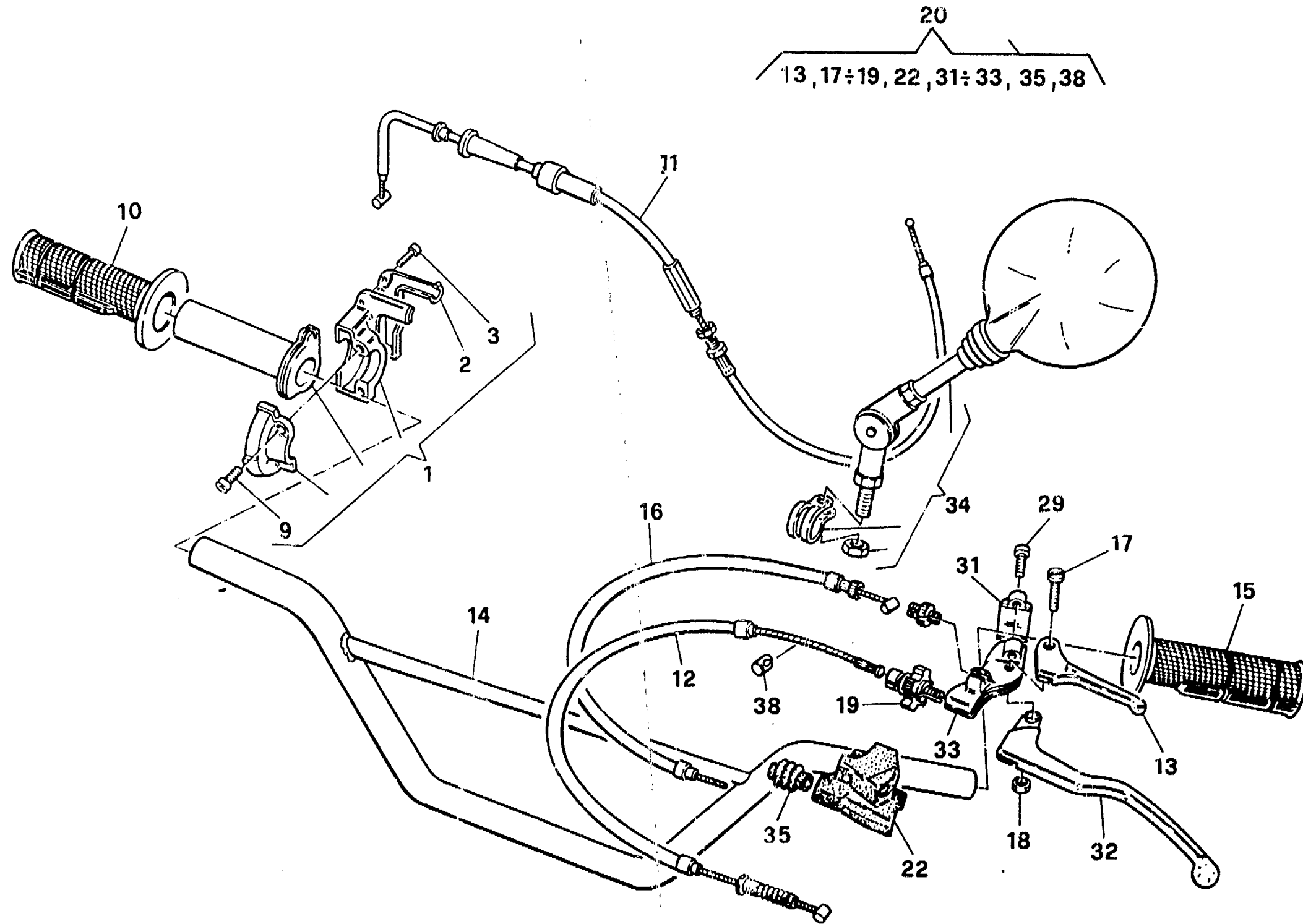



**MANUBRIO E COMANDI - HANDLEBAR AND CONTROLS
GUIDON ET COMMANDES - LENKER UND STEUERORGANE
MANILLAR Y MANDOS**

TAVOLA
DRAWING
TABLE
BILD
TABLA

17

**TE - TC
610 / 95**

Note Notes Marka Notas	Pos. No. Index Pos.	N. Cod. Code No. Nr. Code Code Nr N. Cod.	DENOMINAZIONE	NAME	DESIGNATION	BESHREIBUNG	DENOMINACION	O.ia O.ry O.ia M.ge C.ad	Validità Validity Validez Gültig Validez
	1	8000 75155	Comando gas completo	Throttle control compl.	Commande gaz compl.	Gasgriff kpl.	Accionam. acelerador compl.	1	
	2	8000 75310	Coperchio	Cover	Couvercle	Deckel	Tapa	1	
	3	8000 66774	Vite	Screw	Vis	Schraube	Tornillo	2	
	9	60N10 7330	Vite	Screw	Vis	Schraube	Tornillo	2	
	10	80A0 76688	Manopola Dx.	R.H. grip	Poignée G.	Griff R.	Manopla der.	1	
	11	8000 75842	Trasmissione comando gas	Throttle wire	Fil comm. gaz	Gaszugkabel	Trans. accionam. acelerador	1	
	12	8000 70997	Trasmissione comando frizione	Clutch transm.	Transm. com. embrayage	Führungssteuer. der Kupplung	Tran. mando embrague compl.	1	
	13	8000 66551	Leva decompressore compl.	Decompression lever	Levier décompression	Dekompressions-hebel	Palanca decompressore	1	
	14	80A0 53018	Manubrio	Hanblebar	Guidon	Lenker	Manillar	1	
★	14	8000 54274	Manubrio	Hanblebar	Guidon	Lenker	Manillar	1	
	15	80A0 76687	Manopola Sx.	L.H. grip	Poignée G.	L. Griff	Manopla izrda.	1	
	16	8000 79754	Trasmissione decompressore	Decompression transm.	Trasm. décompression	Dekompressions Kabel	Transm. decompressore	1	
	17	8000 47824	Vite	Screw	Vis	Schraube	Tornillo	1	
	18	8000 38799	Dado	Nut	Ecrou	Mutter	Tuerca	1	
	19	8000 48916	Gruppo registro	Adjuster set	Groupe reglage	Kupplungsreglergruppe	Grupo regul.	1	
	20	8000 71232	Comando frizione compl.	Clutch control lever, assy	Levier com. embrayage compl.	Kupplungshebel, Kpl.	Palanca embrague comp.	1	
	22	8000 66489	Coprileva	Lever cover	Couvre levier	Hebeldeckel	Cubre-palanca mando embr.	1	
	29	8000 62728	Vite	Screw	Vis	Schraube	Tornillo	2	
	31	8000 70698	Cavalotto	U-bolt	Cavalier	Bügelbolzen	Caballete	1	
	32	8000 66487	Leva frizione	Clutch lever	Levier embrayage	Kupplungshebel	Palanca mando embrague	1	
	33	8000 66552	Supporto	Support	Support	Halterung	Soporte elástico	1	
●	34	8000 65437	Specchietto retrov. Dx. e Sx.	Driving mirror	Rétroviseur	Rückspiegel	Espejo retrovisor	2	
	35	8000 48918	Protezione	Guard	Protection	Schutz	Protección	1	
	38	8000 38802	Bariotto	Retainer	Cliquet	Sicherungsring	Barrilejo	1	

● = In dotazione modello TE
★ = A richiesta

● = To issue TE model
★ = Upon request

● = En nécessaire modèle TE
★ = Sur demande

● = Ausrüstungsteile modell TE
★ = Auf Anfrage

● = En dotacion modelo TE
★ = Bajo pedido

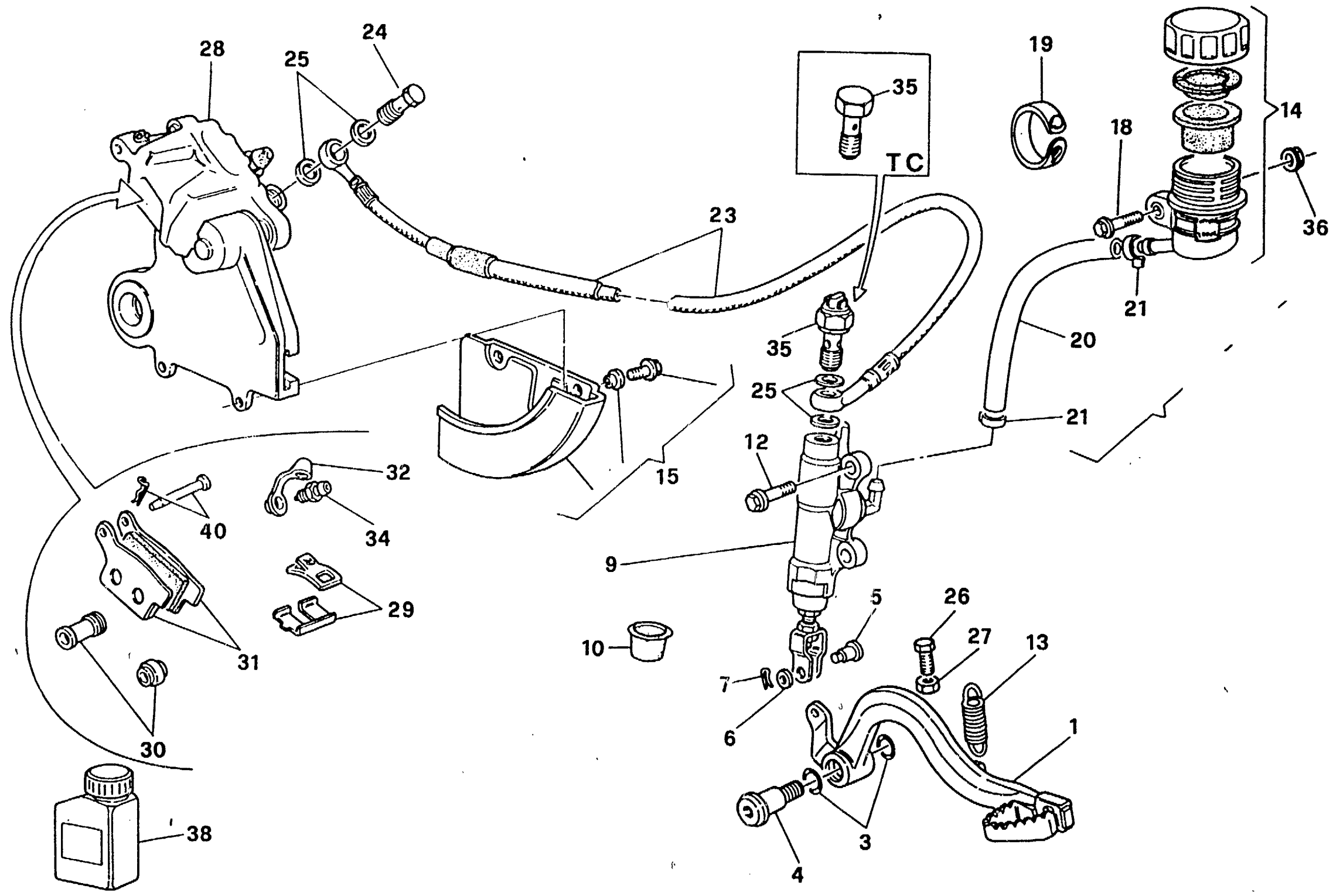



FRENO IDRAULICO POSTERIORE - REAR HYDRAULIC BRAKE
FREIN HYDRAULIQUE ARRIERE - HINTERBREMSE
FRENO HIDRAULICO TRASERO

TAVOLA
DRAWING
TABLE
BILD
TABLA

18

TE - TC
610 / 95

Note Notes Marka Notas	Pos. No. N. Index Pos.	N. Cod. Code No. Nr. Code Code Nr N. Cod.	DENOMINAZIONE	NAME	DESIGNATION	BESHREIBUNG	DENOMINACION	Q.ta Q.ty Q.té M.ge C.ad	Valida Validity Validé Gültig Validez
	1	8A00 64708	Leva comando freno	Brake control lever	Levier comm. frein	Bremshebel	Palanca accionamiento freno	1	
	2	62N1 15780	Rosetta ondulata	Washer	Rondelle	Scheibe	Arandela	1	
	3	8000 22551	Ariello OR	O-Ring	Bague OR	O-Ring	Anillo OR	2	
	4	8000 55902	Vite	Screw	Vis	Schraube	Tornillo	1	
	5	8000 70696	Astina	Control rod	Coulisseau	Steuerstange	Varilla	1	
	6	8000 56377	Rosetta	Washer	Rondelle	Scheibe	Arandela	1	
	7	64N1 20068	Copiglia	Split pin	Goupille	Splint	Clavija	1	
	9	8000 76338	Pompa comando freno compl.	Brake pump	Pompe frein	Bremspumpe	Bomba freno	1	
	10	8000 79075	Cuffia	Cap	Capuchons	Kappa	Gorro	1	
	12	8000 62726	Vite	Screw	Vis	Schraube	Tornillo	2	
	13	8000 55903	Molla	Spring	Ressort	Feder	Resorte	1	
	14	8000 61078	Serbatoio olio completo	Oil tank assy	Reservoir huile compl.	Öltank Kpl.	Depósito aceite completo	1	
	15	8000 76289	Kit protezione disco	Kit guard	Kit protection	Kit Schutz	Kit protección	1	
	18	8000 62727	Vite	Screw	Vis	Schraube	Tornillo	1	
	19	8000 53724	Fascetta	Clamp	Collier	Schelle	Banda	1	
	20	8A00 70266	Tubazione	Pipe	Tuyau	Rohr	Tube	1	
	21	8000 42349	Molletta	Spring	Ressort	Feder	Resorte	1	
	23	8000 78326	Tubo mandata olio	Pipe	Tuyau	Rohr	Tube	1	
	24	8000 57155	Vite	Screw	Vis	Schraube	Tornillo	1	
	25	8000 21480	Rosetta di tenuta	Washer	Rondelle	Scheibe	Arandela	4	
	26	60N10 2511	Vite	Screw	Vis	Schraube	Tornillo	1	
	27	61N1 15062	Dado	Nut	Ecrou	Mutter	Tuerca	1	
	28	8000 77745	Pinza freno completa	Brake caliper assy	Pince de frein, compl.	Bremszange, Kpl.	Pinza freno compl.	1	
	29	8000 79065	Gruppo revisione mollette	Spring set	Kit revision ressort	Federsatz	Grupo revis. resorte	1	
	30	8000 79066	Gruppo revisione cuffie	Caps revision set	Groupe revision capuchons	Kappa reparatursatz	Grupo revis. gorro	1	
	31	8000 79072	Coppia pastiglie	Pads pair	Paire plaquettes	Bremsbelagpaar	Pareja pastillas	1	

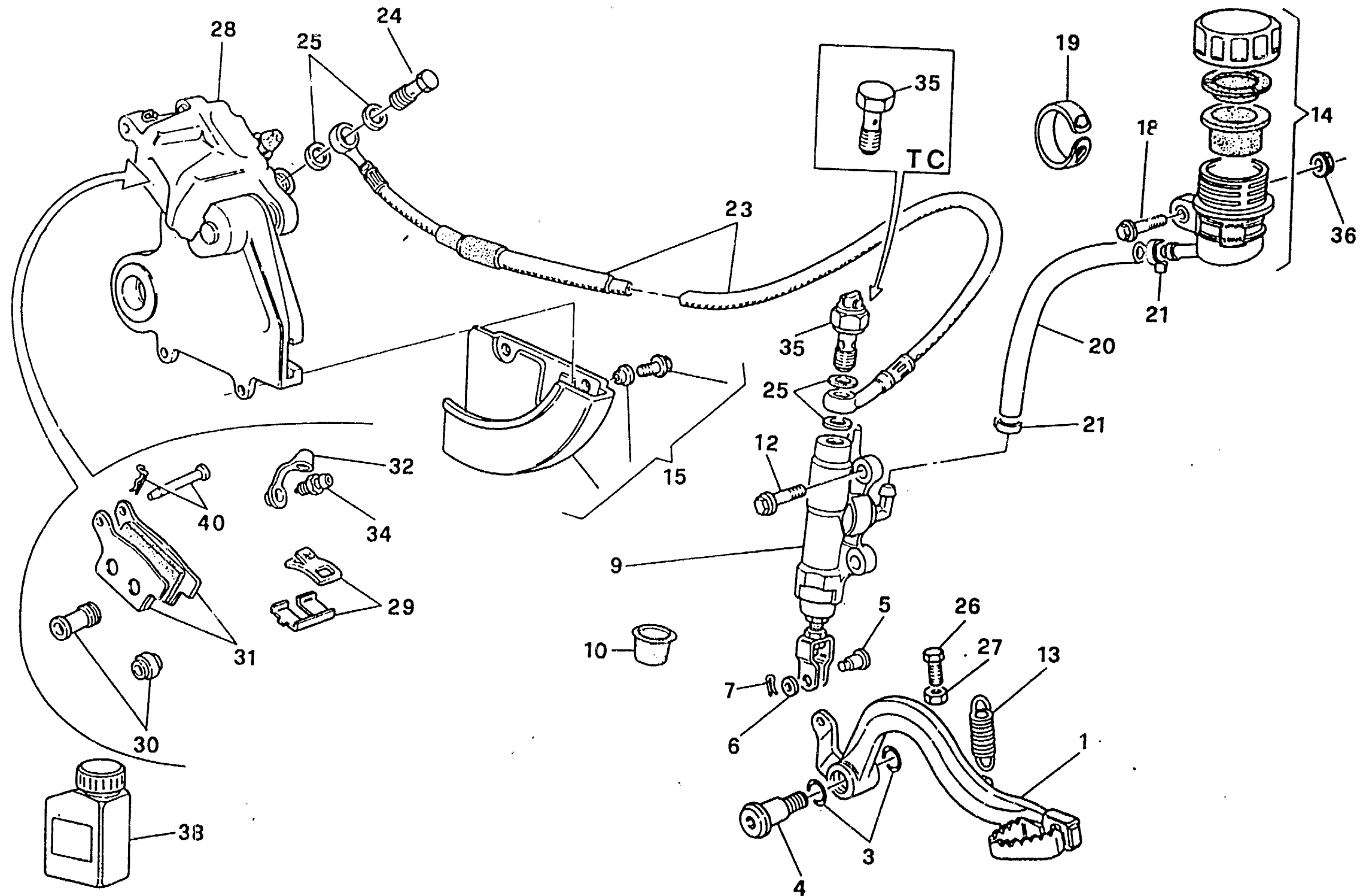



FRENO IDRAULICO POSTERIORE - REAR HYDRAULIC BRAKE
FREIN HYDRAULIQUE ARRIERE - HINTERBREMSE
FRENO HIDRAULICO TRASERO

TAVOLA
DRAWING
TABLE
BILD
TABLA

18

TE - TC
610 / 95

Note Notes Notas	Pos. No. N. Index Pos.	N. Cod. Code No. Nr. Code Code Nr N. Cod.	DENOMINAZIONE	NAME	DESIGNATION	BESCHREIBUNG	DENOMINACION	Q.tà Qty Q.tà M. pe C. ad	Validità Validity Validité Gültig Validez
▼	31	8A00 79072	Coppia pastiglie	Pads pair	Paire plaquettes	Bremsbelagpaar	Pareja pastillas	1	
	32	8000 53259	Parapolvere	Dust cover	Para poussière	Staubdeckel	Tapa retención polvo	1	
	34	8000 60404	Gruppo revisione spurgo	Bleeding set	Kit de revision curage	Reinigungsatz	Grupo revis. purga	1	
★	35	8000 37891	Interruttore stop posteriore	Stop switch	Interrupteur stop	Stopschalter	Interruptor stop	1	
☆	35	8000 57155	Vite	Screw	Vis	Schraube	Tomillo	1	
	36	8000 44240	Dado	Nut	Ecrou	Mutter	Tuerca	1	
▼	38	8000 71445	Olio freni	Brake oil	Huile de frein	Bremsöl	Aceite freno	1	
	40	8000 79073	Gruppo revisione perni pastiglie	Pad pin set	Kit revision pivots pastilles	Bremsbelagbolzensatz	Grupo revis. pernos pastillas	1	
			▼ = A richiesta	▼ = Upon request	▼ = Sur demande	▼ = Auf Anfrage	▼ = Bajo pedido		
			★ = Modello TE	★ = TE model	★ = Modèle TE	★ = Modell TE	★ = Modelo TE		
			☆ = Modello TC	☆ = TC modell	☆ = Modèle TC	☆ = Modell TC	☆ = Modelo TC		

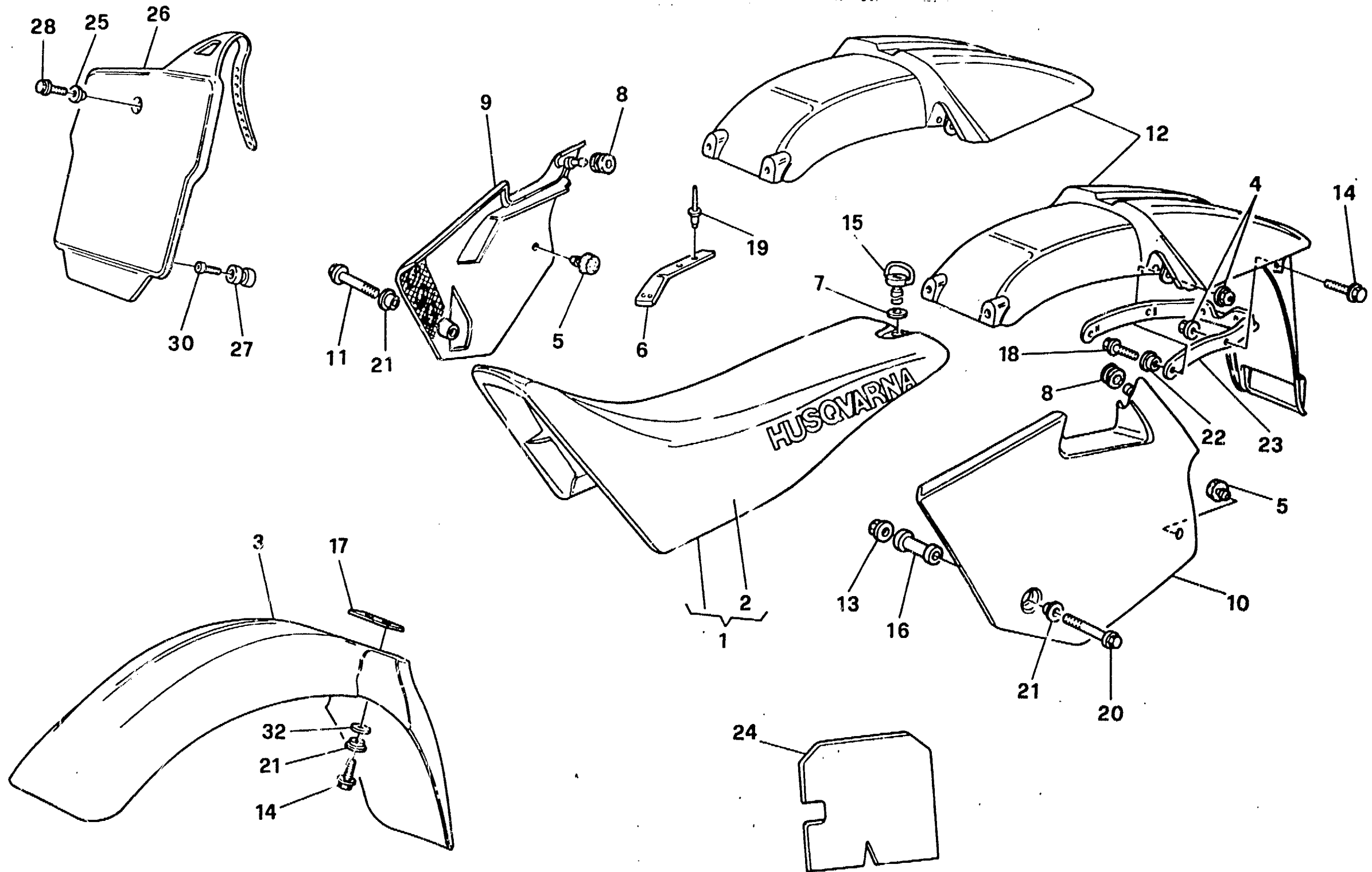



PANNELLI, PARAFANGHI, SELLA - PANEL, FENDERS, SEAT
 PANNEAU, GARDE-BOUES, SIEGE - STREIFEN, KOTFLUGEL, SATTEL
 PANELO, GUARDABARROS, SILLIN

TAVOLA
 DRAWING
 TABLE
 BILD
 TABLA

19

TE - TC
 610 / 95

Note Notes Notas	Pos. No. N. Index Pos.	N. Cod. Code No. Nr. Code Code Nr N. Cod.	DENOMINAZIONE	NAME	DESIGNATION	BESCHREIBUNG	DENOMINACION	Q.tà Q.ty Q.ty M.ge C. ad	Validità Validity Valido Gültig Validez
★	1	8A00 79760	Sella	Seat	Siège	Sattel	Sillin	1	
☆	1	8000 79760	Sella	Seat	Siège	Sattel	Sillin	1	
	2	8000 79761	Rivestimento sella	Saddle covering	Revetement selle	Sattelverkleidung	Revestimiento sillin	1	
▲	2	8000 71641	Rivestimento sella "Rain"	Saddle covering "Rain"	Revetement selle "Rain"	Sattelverkleidung "Rain"	Revestimiento sillin "Rain"	1	
	3	80B0 73395	Parafango anteriore	Front mudguard	Garde-boue avant	Vord. Kotfluegel	Guarda-barros delantero	1	
	4	8000 44240	Dado	Nut	Ecrou	Mutter	Tuerca	2	
	5	8000 45490	Gommino	Rubber pad	Pièce caoutchouc	Gummistück	Junta de goma	2	
☆	6	8000 75941	Protezione	Guard	Protection	Schutz	Protección	1	
	7	8000 69149	Rosetta elastica	Spring washer	Rondelle élastique	Federscheibe	Arandela elástica	4	
	8	8000 18048	Gommino	Rubber pad	Pièce caoutchouc	Gummistück	Junta de goma	2	
	9	8000 70208	Pannello destro	R.H. panel	Panneau, D.	Streifen, R.	Panel der.	1	
	10	80B0 70209	Pannello sinistro	L.H. panel	Panneau, G.	Streifen, L.	Panel izq.	1	
	11	8E00 67545	Vite	Screw	Vis	Schraube	Tornillo	1	
★	12	80B0 69430	Parafango posteriore	Rear mudguard	Garde-boue arriere	Hint.Kotfluegel	Guarda-barros trasero	1	
☆	12	80B0 70009	Parafango posteriore	Rear mudguard	Garde-boue arriere	Hint.Kotfluegel	Guarda-barros trasero	1	
	13	8000 44240	Dado	Nut	Ecrou	Mutter	Tuerca	1	
	14	8000 62728	Vite	Screw	Vis	Schraube	Tornillo	2	
	14	8000 62727	Vite	Screw	Vis	Schraube	Tornillo	4	
	15	8000 69148	Perno	Pin	Pivot	Bolzen	Perno	4	
	16	1519767-03	Distanziale	Spacer	Entretoise	Distanzstück	Separador	1	
	17	8000 69997	Piastrina	Plate	Plaquette	Plättchen	Placa	1	
	18	8000 62730	Vite	Screw	Vis	Schraube	Tornillo	2	
☆	19	8000 72510	Rivetto	Rivet	Rivet	Niet	Remache	1	
	20	8C00 67545	Vite	Screw	Vis	Schraube	Tornillo	1	
	21	8000 69429	Bussola	Bushing	Douille	Buchse	Manguito	6	
	22	8000 45495	Bussola	Bushing	Douille	Buchse	Manguito	4	

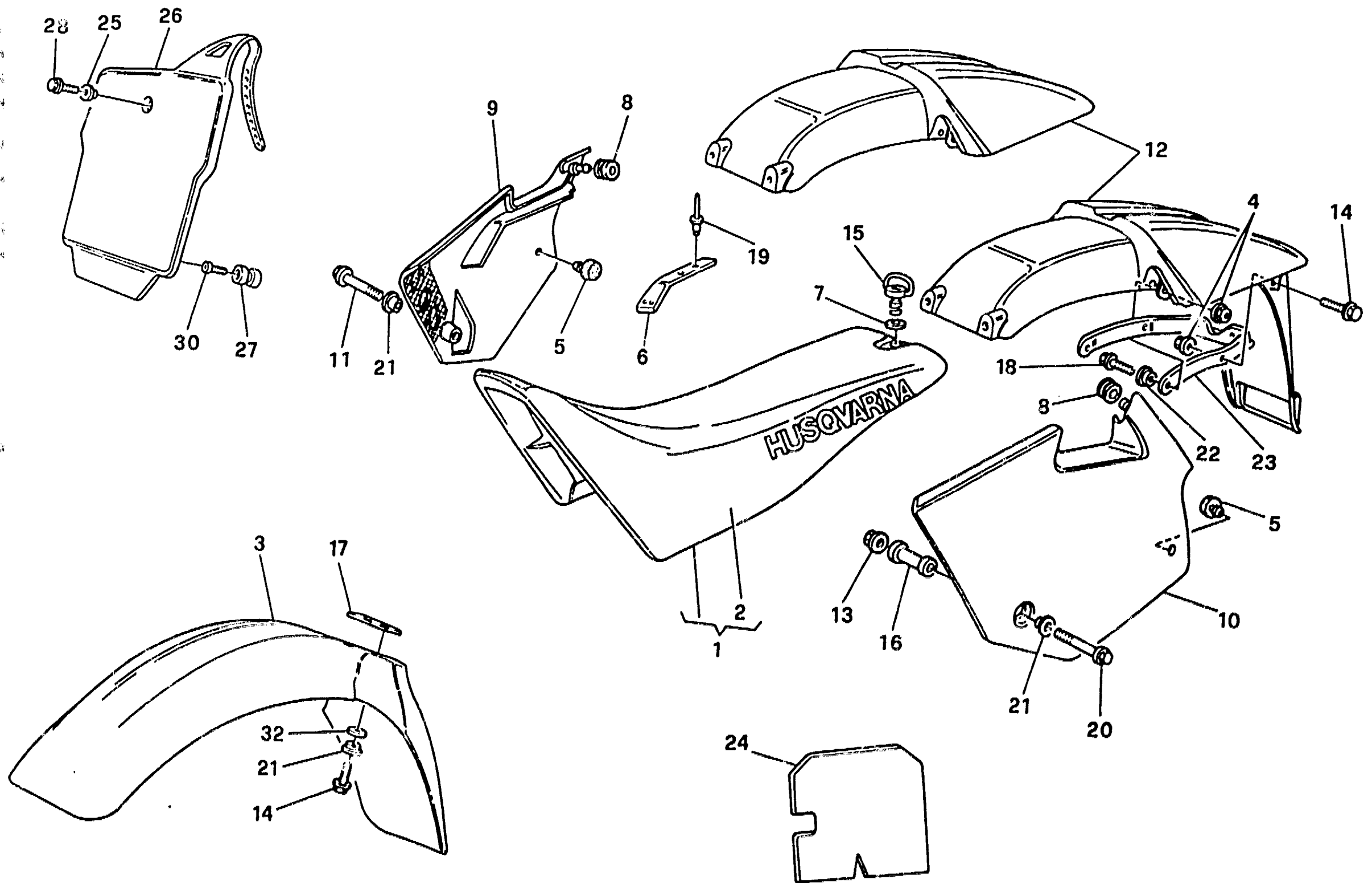



PANNELLI, PARAFANGHI, SELLA - PANEL, FENDERS, SEAT
 PANNEAU, GARDE-BOUES, SIEGE - STREIFEN, KOTFLUGEL, SATTEL
 PANELO, GUARDABARROS, SILLIN

TAVOLA
DRAWING
TABLE
BILD
TABLA

19

TE - TC
610 / 95

Note Notes Marka Notas	Pos. No. N. Index Pos.	N. Cod. Code No. Nr. Code Code Nr N. Cod.	DENOMINAZIONE	NAME	DESIGNATION	BESHREIBUNG	DENOMINACION	Q.ta Q.ty Q.té M.ge C.ad.	Validità Validity Validité Gültig Validez
★	23	8000 72396	Piastra rinforzo	Plate	Plaque	Platte	Placa	1	
	24	8000 72348	Protezione	Guard	Protection	Schutz	Protección	1	
☆	25	8B00 69282	Bussola	Bushing	Douille	Buchse	Manguito	1	
☆	26	80B0 73396	Portanumero	Number holder	Porte numero	Nummerträger	Porta numero	1	
☆	27	8000 79860	Distanziale	Spacer	Entretoise	Distanzstück	Separador	2	
☆	28	8C00 67997	Vite	Screw	Vis	Schraube	Tomillo	1	
☆	30	8000 55241	Vite	Screw	Vis	Schraube	Tomillo	2	
	32	8000 56359	Rosetta	Washer	Rondelle	Scheibe	Arandela	4	
			▲ = A richiesta	▲ = Upon request	▲ = Sur demande	▲ = Auf Anfrage	▲ = Bajo pedido		
			★ = Modello TE	★ = TE model	★ = Modèle TE	★ = Modell TE	★ = Modelo TE		
			☆ = Modello TC	☆ = TC modell	☆ = Modèle TC	☆ = Modell TC	☆ = Modelo TC		

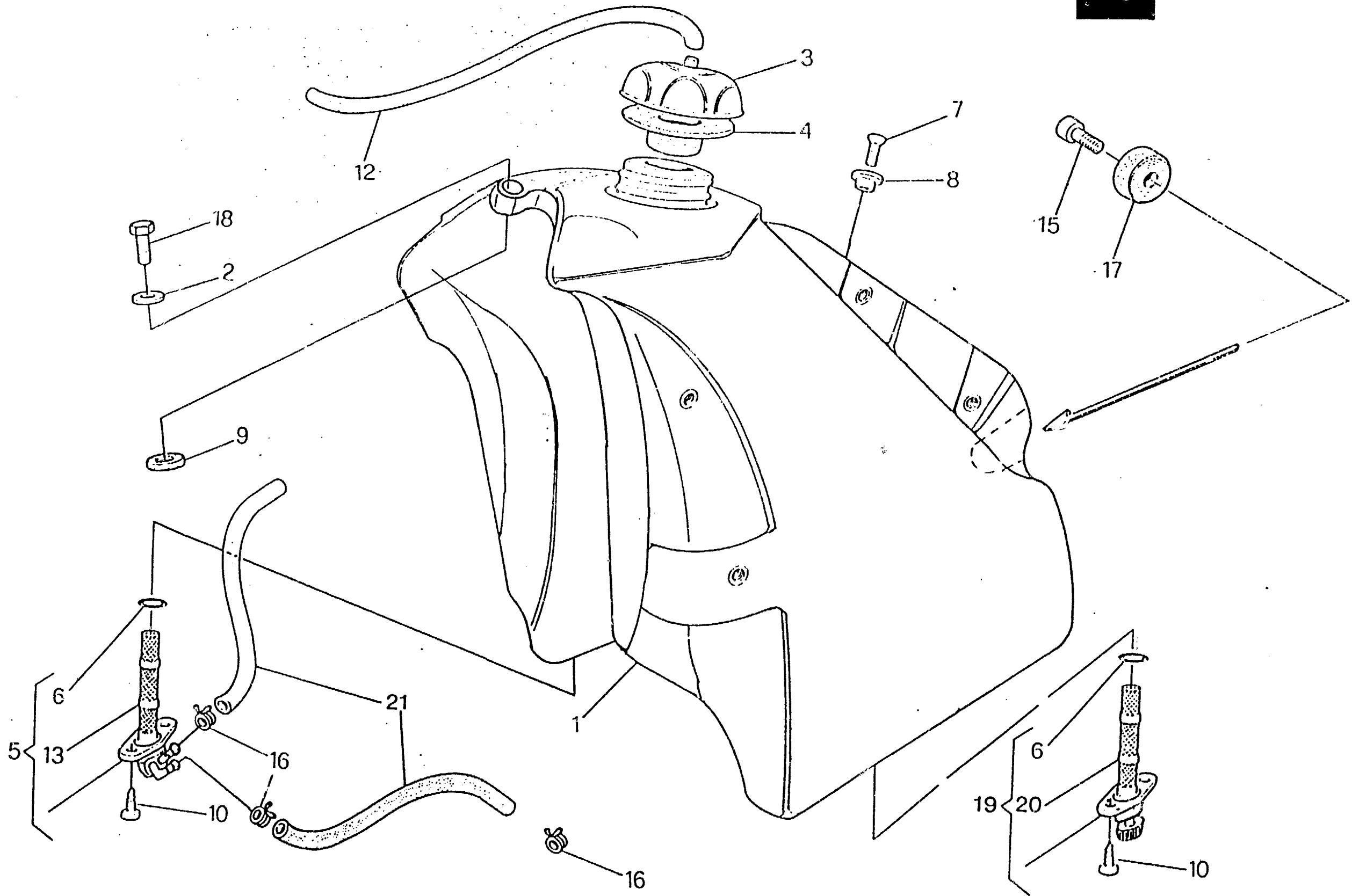



SERBATOIO - GAS TANK
RESERVOIR - KRAFTSTOFFBEHALTER
DEPOSITO

TAVOLA
 DRAWING
 TABLE
 BILD
 TABLA

20

TE - TC
610 / 95

Note Notes Notas	Pos. No. Index Pos.	N. Cod. Code No. Nr. Code Code Nr N. Cod.	DENOMINAZIONE	NAME	DESIGNATION	BESHREIBUNG	DENOMINACION	Q.tà Q.ty Q.te M.ge C.ad	Valdka Valdky Valdko Cullig Valdez
	1	80B0 66630	Serbatoio carburante	Fuel tank	Réservoir à carburant	Tank	Depósito gasolina	1	
	2	8000 30319	Rosetta piana	Washer	Rondelle	Scheibe	Arandela	1	
	3	8000 65604	Tappo	Plug	Bouchon	Verschluss	Tapón	1	
	4	8000 56381	Guarnizione	Gasket	Garniture	Dichtung	Junta	1	
	5	8000 66648	Rubinetto Dx.	R.H. cock	Robinet D.	R.Kraftstoffahn	Llave de paso der.	1	
	6	80000 1199	Anello OR	O-Ring	Bague OR	O-Ring	Anillo OR	2	
	7	60N10 4134	Vite	Screw	Vis	Schraube	Tornillo	1	
	8	8000 66238	Distanziale	Spacer	Entretoise	Distanzstück	Separador	1	
	9	8000 61362	Tampone	Pad	Tampon	Stopfen	Tampón	1	
	10	8000 37745	Vite	Screw	Vis	Schraube	Tornillo	4	
	12	8B00 38752	Tubetto sfiato	Battery breather pipe	Event batterie	Batterieentlüfter	Tubo de purga batería	1	
	13	3000 38748	Filtro benzina	Fuel filter	Filtre essence	Benzinfilter	Filtro gasolina	1	
	15	60N10 7350	Vite	Screw	Vis	Schraube	Tornillo	2	
	16	8000 18922	Anello elastico	Split ring	Anneau ressort	Sprengring	Anillo elástico	3	
	17	8000 40813	Tampone	Pad	Tampon	Stopfen	Tampón	2	
	18	8000 62725	Vite	Screw	Vis	Schraube	Tornillo	1	
	19	8000 67440	Rubinetto Sx.	L.H. cock	Robinet G.	L.Kraftstoffahn	Llave de paso izq.	1	
	20	8000 67700	Filtro benzina	Fuel filter	Filtre essence	Benzinfilter	Filtro gasolina	1	
	21	1514057-11	Condotto benzina	Pipe	Tuyau	Rohr	Tubo	2	

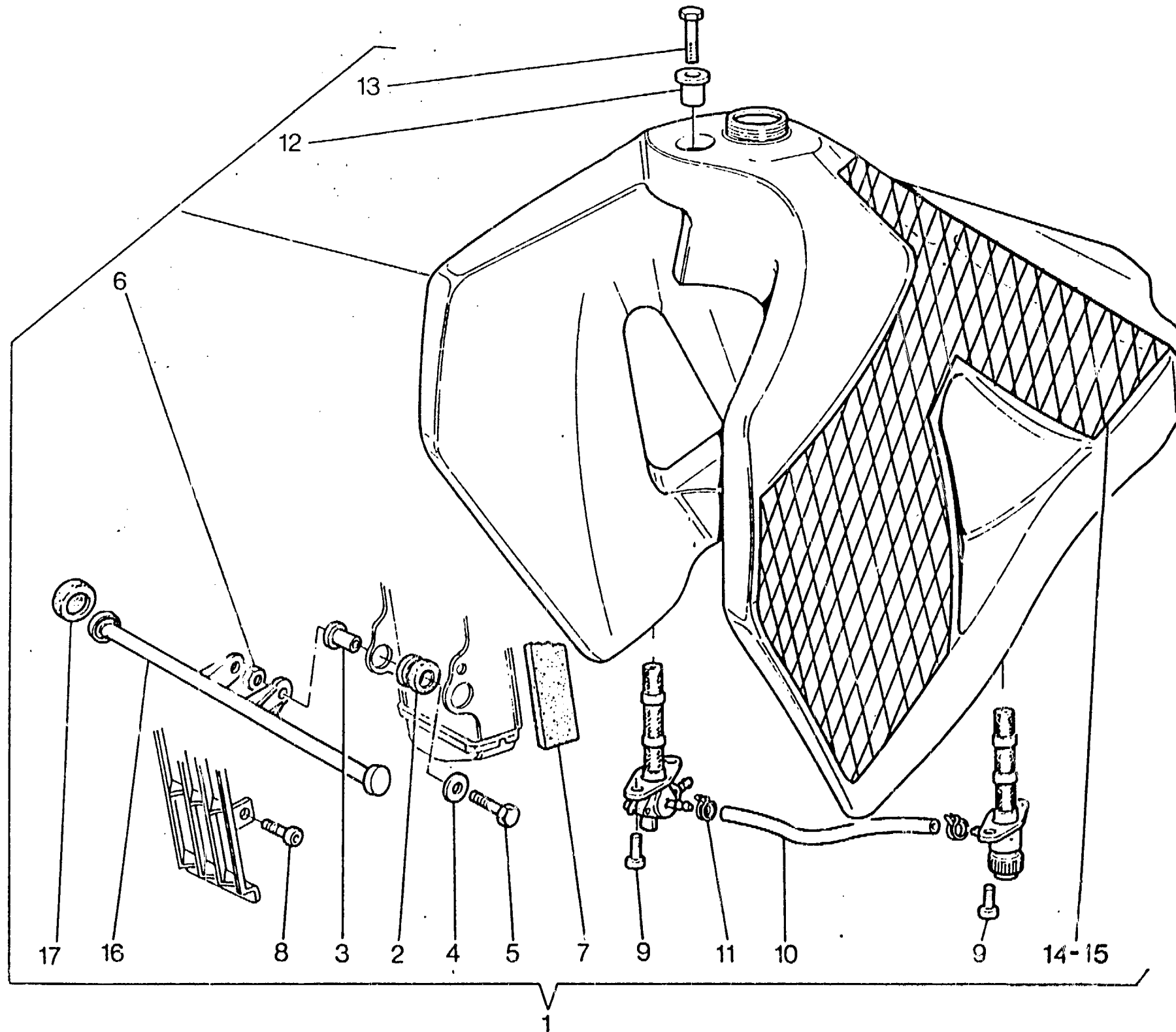



SERBATOIO MAGGIORATO - LARGE GAS TANK
RESERVOIR DE PLUS GRANDE CAPACITE - UEBERDIMENSIONIERTER BEHALTER
DEPOSITO AMBLIADO

TAVOLA
DRAWING
TABLE
BILD
TABLA

20A

TE - TC
610 / 95

Note Notes Marka Notas	Pos. No. Index Pos.	N. Cod. Code No. Nr. Code Code Nr N. Cod.	DENOMINAZIONE	NAME	DESIGNATION	BESHREIBUNG	DENOMINACION	Q.tà Q.ty Q.te M.gs C.ad	Validità Validty Validné Gültig Validez
	1	8000 80257	Kit serbatoio carburante magg.	Kit fuel tank oversize	Gr. réservoir à carburant major.	MaßTank Gruppe	Kit depósito gasolina aument.	1	
	2	8000 59803	Gommino	Rubber pad	Pièce caoutchouc	Gummistück	Junta de goma	2	
	3	8000 59802	Bussola	Bushing	Douille	Buchse	Manguito	6	
	4	8000 59801	Rosetta *	Washer	Rondelle	Scheibe	Arandela	2	
	5	8000 62728	Vite	Screw	Vis	Schraube	Tomillo	2	
	6	8000 44240	Dado	Nut	Ecrou	Mutter	Tuerca	1	
	7	8000 60925	Spessore	Spacer	Entretoise	Distanzstück	Separador	1	
	8	8000 62725	Vite	Screw	Vis	Schraube	Tomillo	2	
	9	8000 62725	Vite	Screw	Vis	Schraube	Tomillo	2	
	10	1514057-04	Condotto benzina	Pipe	Tuyau	Rohr	Tubo	2	
	11	8000 18922	Anello elastico	Split ring	Anneau ressort	Sprengring	Anillo elástico	3	
	12	8A00 59802	Bussola	Bushing	Douille	Buchse	Manguito	6	
	13	8A00 67545	Vite	Screw	Vis	Schraube	Tomillo	2	
	14	8000 80156	Decal. destra	R.H. trim	Décal. D.	Abzi. R.	Cal. der.	1	
	15	8000 80157	Decal. sinistra	L.H. trim	Décal. G.	Abzi. L.	Cal. izq.	1	
	16	8000 72950	Piastra	Plate	Plaque	Platte	Placa	1	
	17	8000 41986	Gommino	Rubber pad	Pièce caoutchouc	Gummistück	Junta de goma	2	

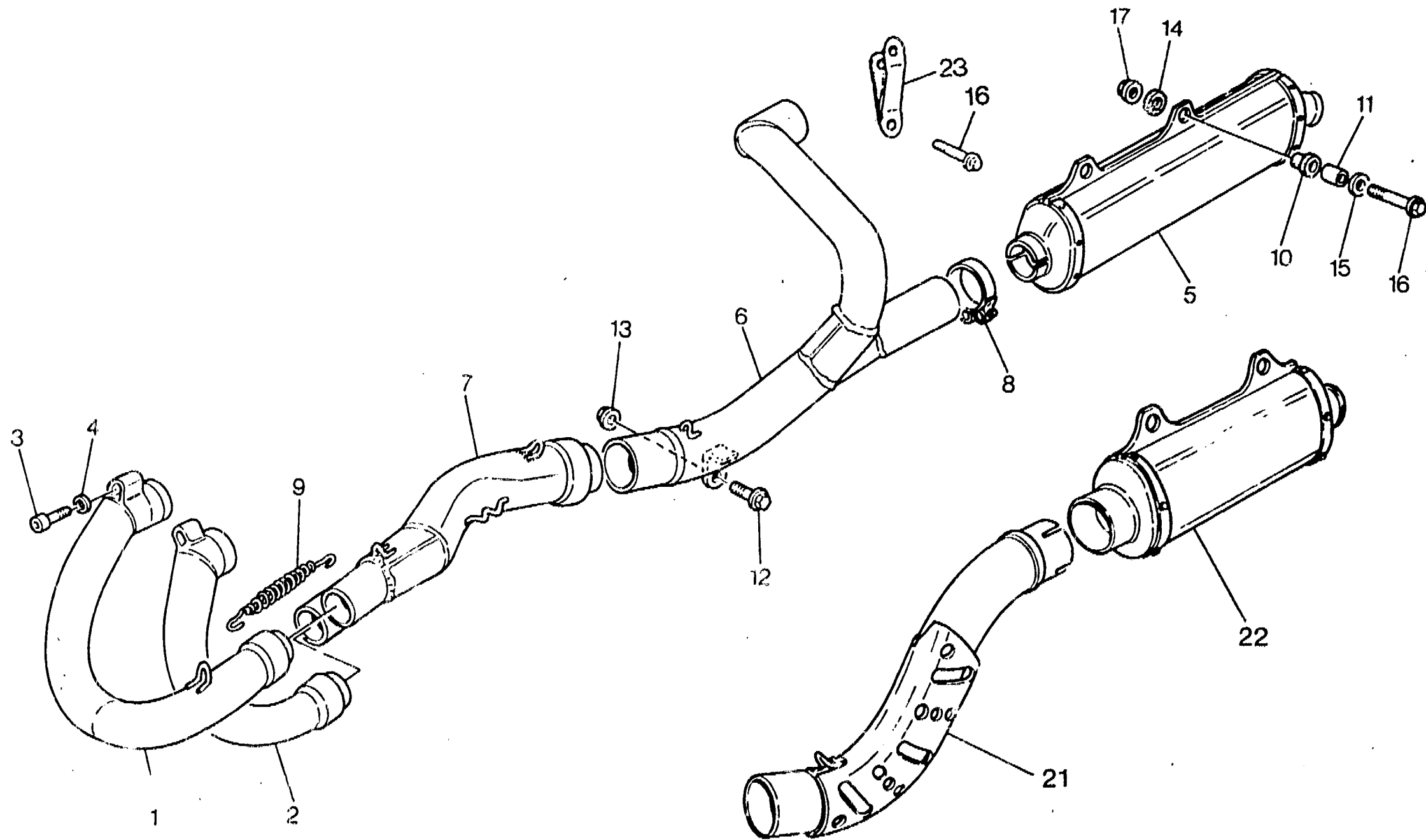



SCARICO - EXHAUST SYSTEM
TUYAU D'ÉCHAPPEMENT - AUSPUFFROHR
TUBO DE ESCAPE

TAVOLA
DRAWING
TABLE
BILD
TABLA

21

TE - TC
610 / 95

Note Notes Notas	Pos. No. N. Index Pos.	N. Cod. Code No. Nr. Code Code Nr N. Cod.	DENOMINAZIONE	NAME	DENOMINATION	BESCHREIBUNG	DENOMINACION	Q.tà Q.ty Q.te M.ge C.ad	Validità Validity Validité Gültig Validez
	1	8B00 71233	Tubo di scarico Dx.	R.H. exhaust pipe	Tuyau d'échapp. D.	Auspuffrohr R.	Tubo de escape der.	1	
	2	8B00 71234	Tubo di scarico Sx.	L.H. exhaust pipe	Tuyau d'échapp. G;	Auspuffrohr L.	Tubo de escape izq.	1	
	3	60N10 2511	Vite	Screw	Vis	Schraube	Tornillo	2	
	4	8000 45499	Rosetta	Washer	Rondelle	Scheibe	Arandela	2	
★	5	8000 80384	Silenziatore	Exhaust silencer	Silencieux d'échappement	Schalldämpfer	Silenciador de escape	2	
★	6	8000 70378	Raccordo tubi scarico	Union exhaust pipe	Raccord tuyau d'échapp.	Anschluss Auspuffrohr	Empalme tubo de escape	1	
	7	8000 71557	Raccordo tubi scarico anter.	Front union exhaust pipe	Raccord tuyau d'échapp. avant	Vorderanschluss Auspuffrohr	Empalme tubo de escape dela.	1	
★	8	8000 72411	Fascetta	Clamp	Collier	Schelle	Banda	2	
☆	8	8A00 72411	Fascetta	Clamp	Collier	Schelle	Banda	2	
	9	8000 67496	Molla	Spring	Ressort	Feder	Resorte	2	
	10	1514107-02	Distanziale in gomma	Rubber spacer	Entretoise en caoutchouc	Gummi Distanzstück	Separador de goma	4	
	11	8000 70379	Distanziale	Spacer	Entretoise	Distanzstück	Separador	4	
	12	8000 69056	Vite	Screw	Vis	Schraube	Tornillo	1	
	13	8000 43928	Dado	Nut	Ecrou	Mutter	Tuerca	1	
	14	1513414-01	Rosetta in gomma	Rubber washer	Rondelle en caoutchouc	Gummischeibe	Arandela de goma	4	
	15	1513743-01	Rosetta piana	Washer	Rondelle	Scheibe	Arandela	4	
★	16	8A00 67545	Vite	Screw	Vis	Schraube	Tornillo	4	
☆	16	8A00 67545	Vite	Screw	Vis	Schraube	Tornillo	2	
	17	8000 44240	Dado	Nut	Ecrou	Mutter	Tuerca	4	
☆	21	8000 72282	Raccordo tubi scarico	Union exhaust pipe	Raccord tuyau d'échapp.	Anschluss Auspuffrohr	Empalme tubo de escape	1	
☆	22	8000 72283	Silenziatore	Exhaust silencer	Silencieux d'échappement	Schalldämpfer	Silenciador de escape	1	
☆	23	8000 71186	Piastrina	Plate	Plaquette	Plättchen	Placa	1	
			★ = Modello TE ☆ = Modello TC	★ = TE model ☆ = TC modell	★ = Modèle TE ☆ = Modèle TC	★ = Modell TE ☆ = Modell TC	★ = Modelo TE ☆ = Modelo TC		

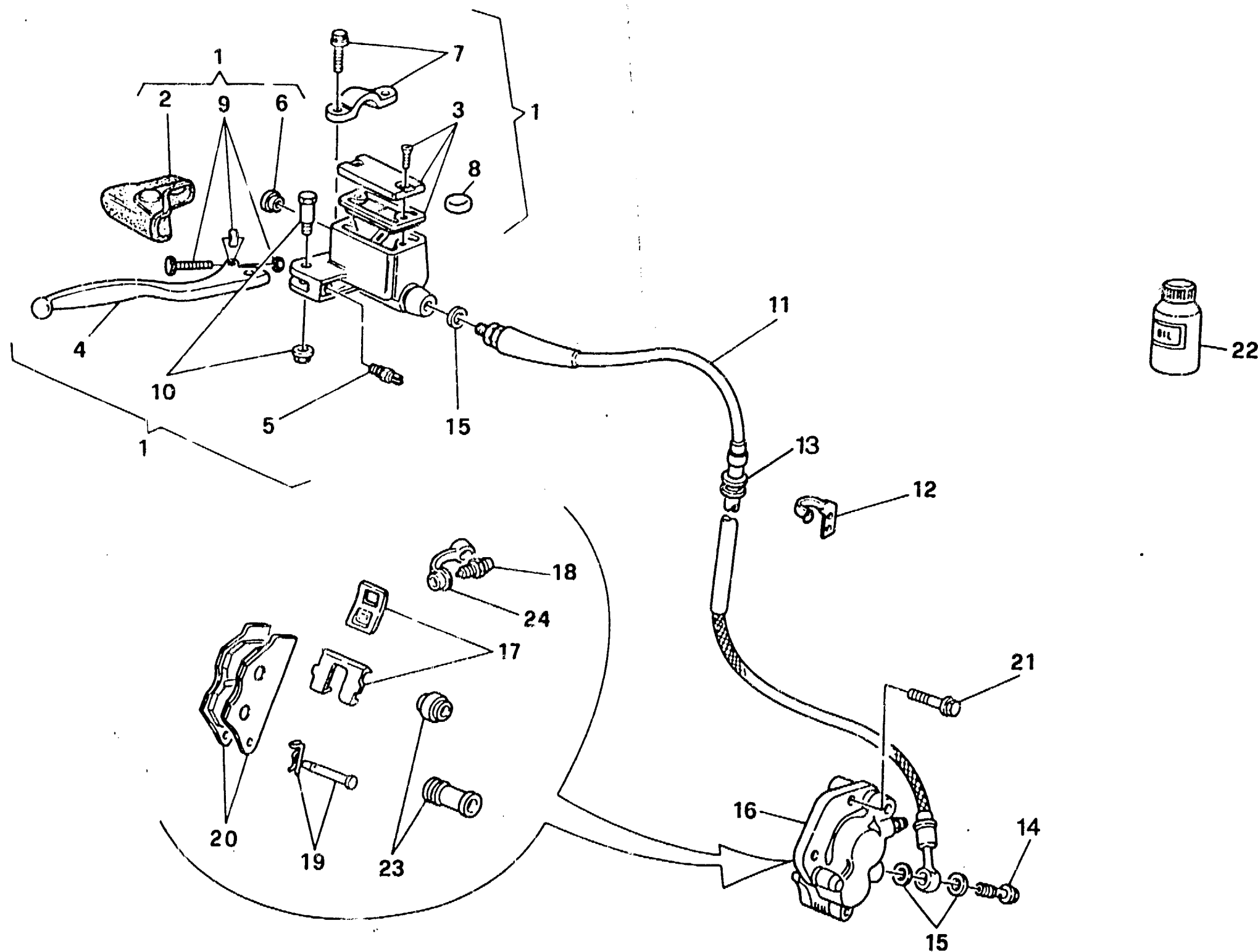



FRENO IDRAULICO ANTERIORE - FRONTHYDRAULIC BRAKE
FREIN HYDRAULIQUE AVANT- VORTERBREMSE
FRENO HIDRAULICO DELANTERA

TAVOLA
DRAWING
TABLE
BILD
TABLA

22

TE - TC
610 / 95

Note Notes Mark Notas	Pos. No. N. Index Pos.	N. Cod. Code No. Nr. Code Code Nr N. Cod.	DENOMINAZIONE	NAME	DESIGNATION	BESHREIBUNG	DENOMINACION	O.là O.ly O.1e M.ge C.ad	Validità Validity Validez Gültig Validez
	1	8000 77740	Pompa comando freno ant.	Brake pump	Pompe frein	Bremspumpe	Bomba freno	1	
	2	8000 79098	Kit cappuccio	Cap kit	Kit capuchon	Kappe Gruppe	Kit capuchón	1	
	3	8000 79069	Kit tappo	Plug kit	Bouchon kit	Verschluss Gruppe	Kit tapón	1	
	4	8000 79096	Kit leva	Lever set	Kit revision levier	Hebelbolzensatz	Grupo revis. pemo	1	
★	5	8000 79071	Interruttore stop	Stop switch	Interrupteur stop	Stopschalter	Interruptor stop	1	
	6	8000 49654	Oblò	Inspection plug	Capuchon de inspection	Stopfen	Portilla	1	
	7	8000 79097	Cavallotto	U-bolt	Cavalier	Bügelbolzen	Caballote	1	
	8	8000 79099	Antiemulsione	Antiemulsion	Antiemulsion	Emulsionswidriger	Antiemulsion	1	
	9	8000 79100	Kit regolazione leva	Lever set	Kit levier	Hebel gruppe.	Grupo palanca	1	
	10	8000 79070	Perno leva	Pin lever	Goujon levier	Bolzen Hebel	Perno palanca	1	
★	11	8B00 77741	Tubo mandata olio	Pipe	Tuyau	Rohr	Tubo	1	
☆	11	8C00 77741	Tubo mandata olio	Pipe	Tuyau	Rohr	Tubo	1	
★	12	8000 71807	Piastrina	Plate	Plaquette	Plättchen	Placa	1	
★	13	8000 71806	Guida cavo	Cable guide	Guide câble	Kabelführung	Guía-cable	1	
	14	8000 57155	Bocchettone	Pipe union	Goulotte	Stutzen	Boca	1	
	15	8000 21480	Rosetta di tenuta	Washer	Rondelle	Scheibe	Arandela	4	
	16	8A00 76031	Pinza freno	Brake caliper	Etrier frein	Bremssattel	Pinza	1	
	17	8000 79065	Kit mollette	Spring kit	Kit ressort	Federgruppe	Grupo resorte	1	
	18	8000 39727	Gruppo revisione spurgo	Bleeding set	Kit de revision curage	Reinigungsatz	Grupo revis. purga	1	
	19	8000 72266	Kit perni pastiglie	Pin kit	Kit pivot	Bolzensgruppe	Grupo pemo	1	
	20	8A00 74181	Coppia pastiglie	Pads pair	Paire plaquettes	Bremsbelagpaar	Pareja pastillas	1	
	21	8000 62733	Vite	Screw	Vis	Schraube	Tornillo	2	
▲	22	8000 71445	Olio freni	Brake oil	Huile frein	BremsÖl	Aceite freni	1	
	23	8000 79066	Gruppo revisione cuffie	Caps revision set	Groupe revision capuchons	Kappa reparatursatz	Grupo revis. gorro	1	
	24	8000 53259	Parapolvere	Dust cover	Para poussière	Staubdeckel	Tapa retención polvo	1	

▲ = A richiesta
★ = Modello TE
☆ = Modello TC

▲ = Upon request
★ = TE model
☆ = TC modell

▲ = Sur demande
★ = Modèle TE
☆ = Modèle TC

▲ = Auf Anfrage
★ = Modell TE
☆ = Modell TC

▲ = Bajo pedido
★ = Modelo TE
☆ = Modelo TC

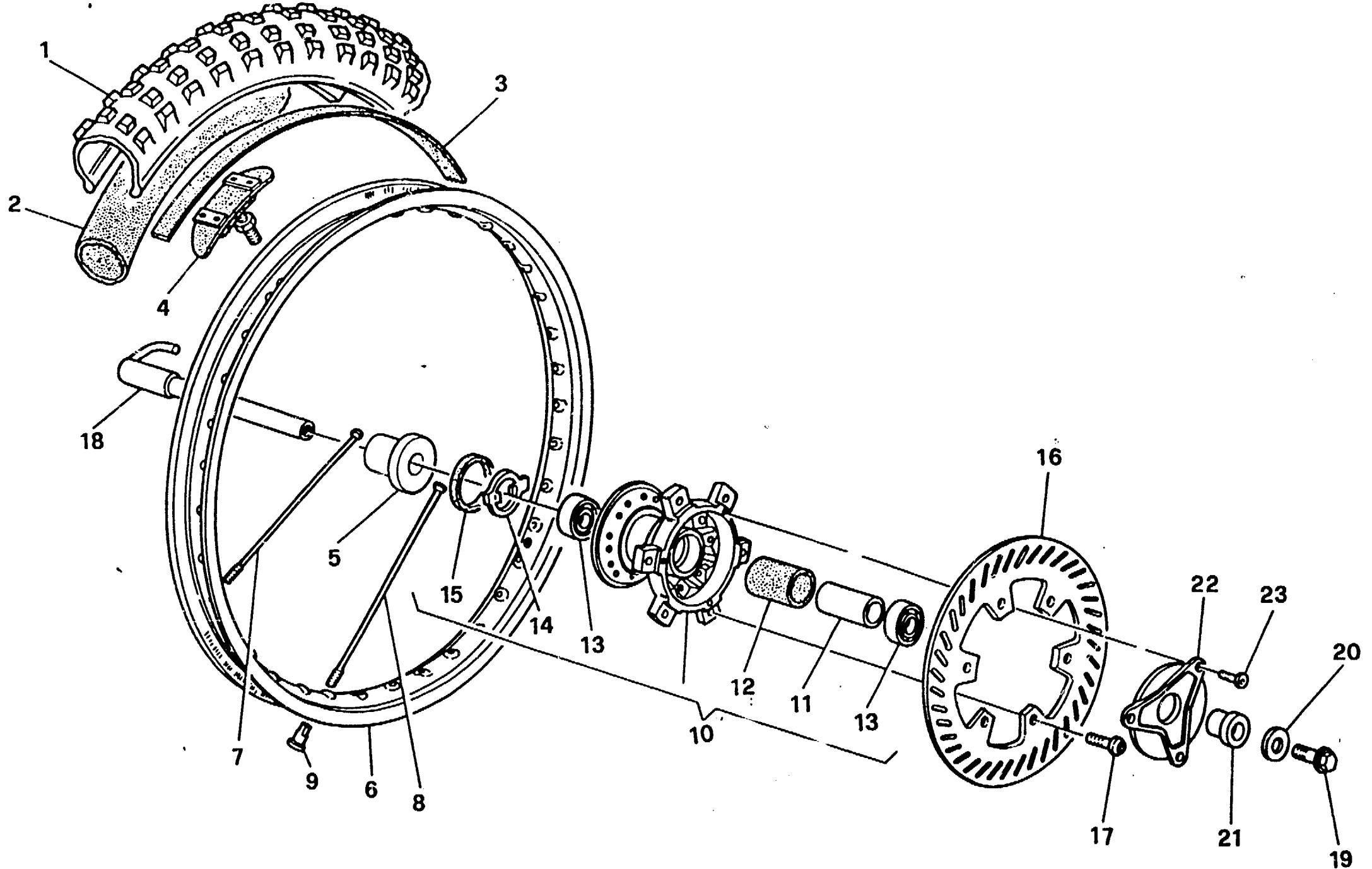



RUOTA ANTERIORE - FRONT WHEEL
ROUE AV. - VORTERRAD
RUEDA DELANTERA

TAVOLA
DRAWING
TABLE
BILD
TABLA

22A

TE - TC
610 / 95

Note Notes Notas	Pos. No. Index Pos.	N. Cod. Code No. Nr. Code Code Nr N. Cod.	DENOMINAZIONE	NAME	DESIGNATION	BESHREIBUNG	DENOMINACION	Q.tà Q.ty Q.te M.ge C.ad	Validità Validity Validés Gültig Validez
◆★	1	8A00 57422	Pneumatico 90/90-21" Michelin	Tyre	Pneu	Reifen	Neumático	1	
◆★	1	8C00 67422	Pneumatico 90/90-21" Pirelli	Tyre	Pneu	Reifen	Neumático	1	
◆☆	1	8000 67422	Pneumatico 90/90-21" Pirelli	Tyre	Pneu	Reifen	Neumático	1	
◆	2	8000 18648	Camera d'aria Pirelli	Air tube	Chambre à air	Luftschlauch	Camara de aire con válvula	1	
◆★	2	8A00 18648	Camera d'aria Michelin	Air tube	Chambre à air	Luftschlauch	Cámara de aire con válvula	1	
	3	8000 13346	Fascia copriraggi	Rim strip	Bande	Band	Banda	1	
	4	8000 49036	Staffa fermacopertone	Bracket	Etrier	Buegel	Brida	1	
☆	5	8000 77749	Distanziale	Spacer	Entretoise	Distanzstück	Separador	1	
	6	8000 53504	Cerchio WM 1/1,6x21"	Rim	Jante	Felge	Llanta	1	
★	7	8000 76298	Raggio destro	Spoke R.	Bras D.	Speiche R.	Radio der.	18	
☆	7	8000 76294	Raggio destro	Spoke R.	Bras D.	Speiche R.	Radio der.	18	
★	8	8000 76297	Raggio sinistro	Spoke L.	Bras G.	Speiche L.	Radio izq.	18	
☆	8	8000 76295	Raggio sinistro	Spoke L.	Bras G.	Speiche L.	Radio izq.	18	
★	9	69N4 29004	Nipplo	Nipple	Nipple	Nippel	Nipple	36	
☆	9	69N4 29005	Nipplo	Nipple	Nipple	Nippel	Nipple	36	
★	10	8000 77744	Mozzo completo	Hub assy	Moyeau compl.	Radnabe, Kpl.	Cubo compl.	1	
☆	10	8000 77748	Mozzo completo	Hub assy	Moyeau compl.	Radnabe, Kpl.	Cubo compl.	1	
	11	8A00 74718	Distanziale	Spacer	Entretoise	Distanzstück	Separador	1	
	12	1516215-01	Portadistanziale	Spacer holder	Porte-entretoise	Abstandstuckhalter	Porta-distancial	1	
	13	8000 39651	Cuscinetto a sfere	Ball bearing	Roulement à billes	Kugellager	Cojinete de bolas	2	
★	14	8000 77884	Anello trascinatore	Ring	Bague	Ring	Anillo	1	
	15	8000 51957	Anello di tenuta	Seal ring	Bague d'étanchéité	Dichtungsring	Anillo de retención	1	
	16	8000 73226	Disco freno	Brake disc	Disque frein	Bremsscheibe	Disco freno	1	
	17	8A00 55241	Vite	Screw	Vis	Schraube	Tomillo	6	
★	18	8000 77699	Perno ruota	Pin	Pivot	Bolzen	Perno rueda	1	
☆	18	8A00 75042	Perno ruota	Pin	Pivot	Bolzen	Perno rueda	1	

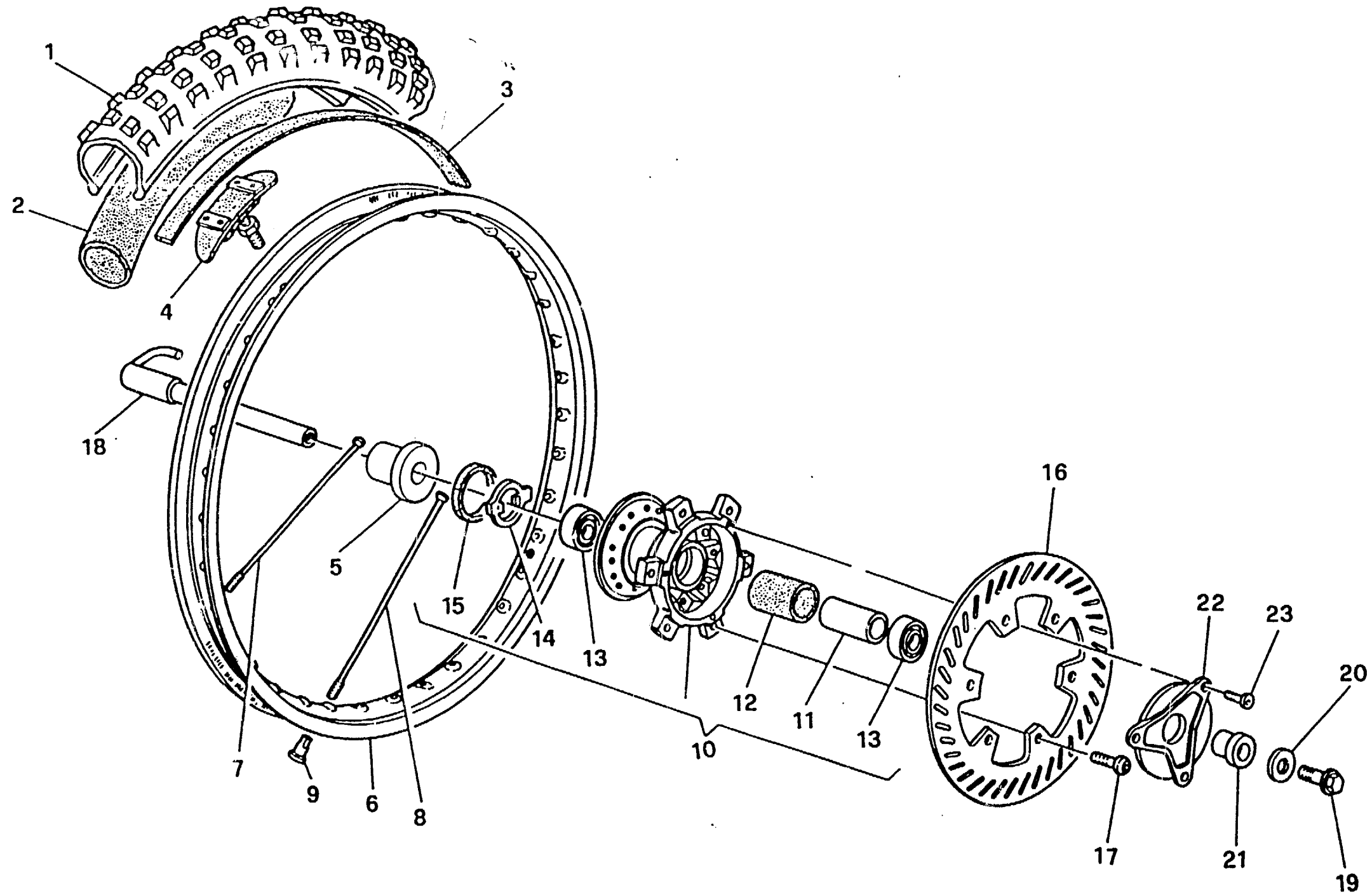



RUOTA ANTERIORE - FRONT WHEEL
ROUE AV. - VORTERRAD
RUEDA DELANTERA

TAVOLA
DRAWING
TABLE
BILD
TABLA

22A

TE - TC
610 / 95

Note Notes Marka Notas	Pos. No. N. Index Pos.	N. Cod. Code No. Nr. Code Code Nr N. Cod.	DENOMINAZIONE	NAME	DESIGNATION	BESCHREIBUNG	DENOMINACION	Q.tà Q.ty Q.té M.ge C.ad	Validità Validity Validez Gültig Validez
	19	8000 48773	Vite	Screw	Vis	Schraube	Tomillo	1	
	20	8000 48772	Rosetta piana	Washer	Rondelle	Scheibe	Arandela	1	
	21	8000 75043	Distanziale	Spacer	Entretoise	Distanzstück	Separador	1	
	22	8800 65572	Coperchio parapolvere	Dust cover	Pare poussière	Staubdeckel	Tapa retención polvo	1	
	23	8A00 62129	Vite	Screw	Vis	Schraube	Tomillo	3	
			◆ = Non fornito ★ = Modello TE ☆ = Modello TC	◆ = Not supplied ★ = TE model ☆ = TC model	◆ = Ne pas fournir ★ = Modèle TE ☆ = Modèle TC	◆ = Nicht versorgt ★ = Modell TE ☆ = Modell TC	◆ = Sin fornitura ★ = Modelo TE ☆ = Modelo TC		

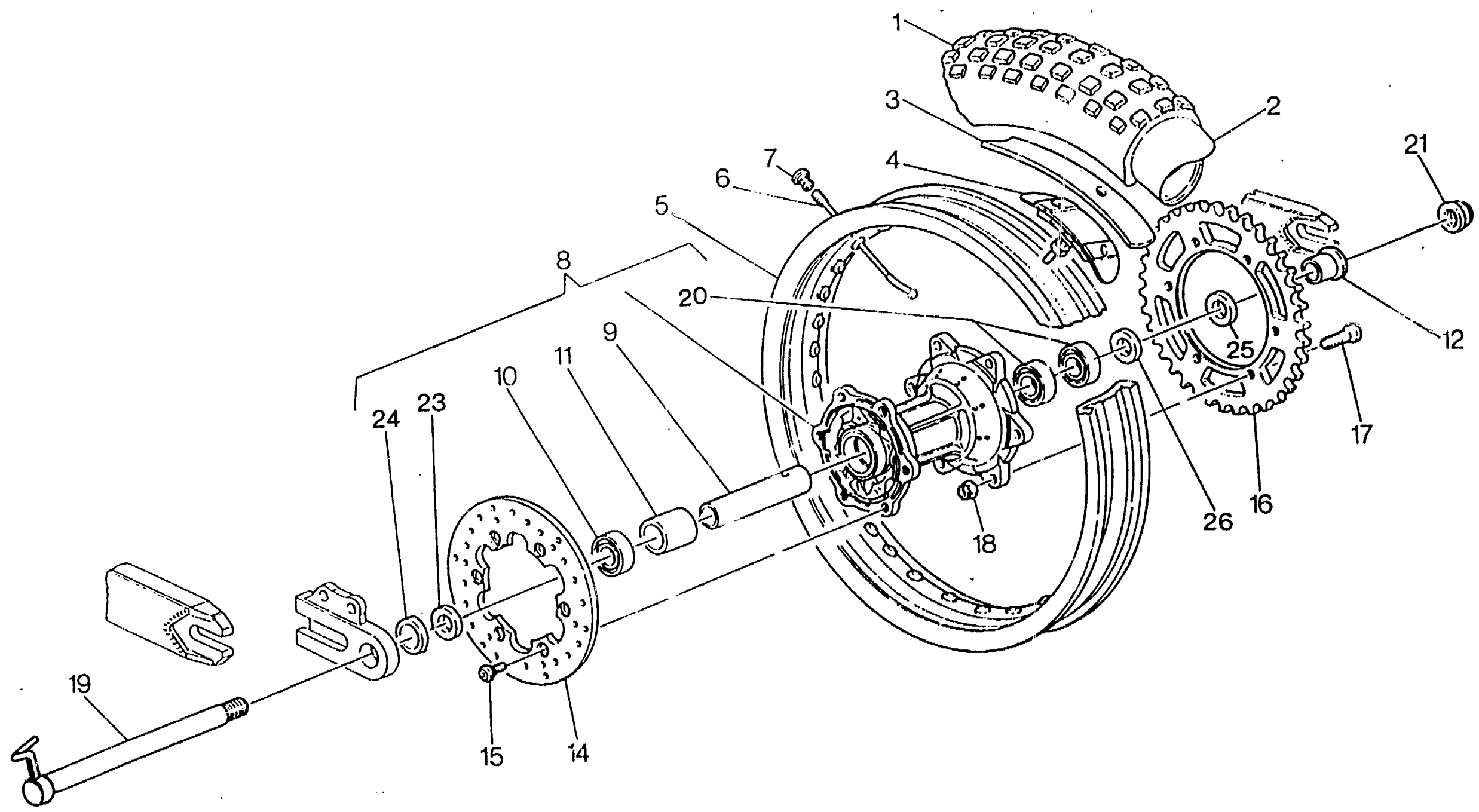



RUOTA POSTERIORE - REAR WHEEL
ROUE ARRIERE - HINTERRAD
RUEDA TRASERA

TAVOLA
DRAWING
TABLE
BILD
TABLA

23

TE - TC
610 / 95

Note Notes Mark Notas	Pos. No. N. Pos.	N. Cod. Code No. Nr. Code Code Nr N. Cod.	DENOMINAZIONE	NAME	DESIGNATION	BESCHREIBUNG	DENOMINACION	Q.tà Q.ty Q.té M.ge C.ad	Validità Validity Validité Gültig Validez
◆★	1	8C00 61348	Pneumatico 140/80-18" Pirelli	Tyre	Pneu	Reifen	Neumático	1	
◆★	1	8A00 61348	Pneumatico 140/80-18" Michelin	Tyre	Pneu	Reifen	Neumático	1	
☆	1	8000 61752	Pneumatico 130/80-19" Pirelli	Tyre	Pneu	Reifen	Neumático	1	
◆★	2	8000 33607	Camera d'aria Pirelli	Air tube	Chambre à air	Luftschlauch	Cámara de aire con válvula	1	
◆★	2	8A00 33607	Camera d'aria Michelin	Air tube	Chambre à air	Luftschlauch	Cámara de aire con válvula	1	
☆	2	8000 60196	Camera d'aria Pirelli	Air tube	Chambre à air	Luftschlauch	Cámara de aire con válvula	1	
★	3	80000 1688	Fascia copriraggi	Rim strip	Bande	Band	Banda	1	
☆	3	8000 10777	Fascia copriraggi	Rim strip	Bande	Band	Banda	1	
★	4	8000 50217	Staffa pneumatico	Bracket	Etrier	Buegel	Brida	1	
☆	4	8000 54073	Staffa pneumatico	Bracket	Etrier	Buegel	Brida	1	
★	5	8000 64886	Cerchio	Rim	Jante	Felge	Llanta	1	
☆	5	8000 58929	Cerchio	Rim	Jante	Felge	Llanta	1	
★	6	8000 76299	Raggio	Spoke	Bras	Speiche	Radio	36	
☆	6	8000 76296	Raggio	Spoke	Bras	Speiche	Radio	36	
	7	69N4 29005	Nipplo	Nipple	Nipple	Nippel	Nipple	36	
	8	8000 69165	Mozzo completo	Hub assy	Moyeau compl.	Radnabe, Kpl.	Cubo compl.	1	
	9	8A00 64983	Distanziale	Spacer	Entretoise	Distanzstück	Separador	1	
	10	8000 55876	Cuscinetto	Bearing	Roulement	Kugellager	Cojinetes	1	
	11	8000 61064	Porta distanziale	Spacer	Entretoise	Distanzstück	Separador	1	
	12	8000 64985	Distanziale	Spacer	Entretoise	Distanzstück	Separador	1	
	14	8A00 55858	Disco freno (Acc. Inox)	Brake disc (Acc. Inox)	Disque frein (Acc. Inox)	Bremsscheibe (Acc. Inox)	Disco freno (Acc. Inox)	1	
	15	8000 55878	Vite	Screw	Vis	Schraube	Tomillo	6	
★	16	8000 60062	Corona Z = 48 (di serie)	Ring gear (supplied)	Couronne (de série)	Kranz (standard)	Corona (de serie)	1	
☆	16	8000 60066	Corona Z = 52 (di serie)	Ring gear (supplied)	Couronne (de série)	Kranz (standard)	Corona (de serie)	1	
■	16	8000 60063	Corona Z = 49	Ring gear	Couronne	Kranz	Corona	1	
■	16	8000 60064	Corona Z = 50	Ring gear	Couronne	Kranz	Corona	1	

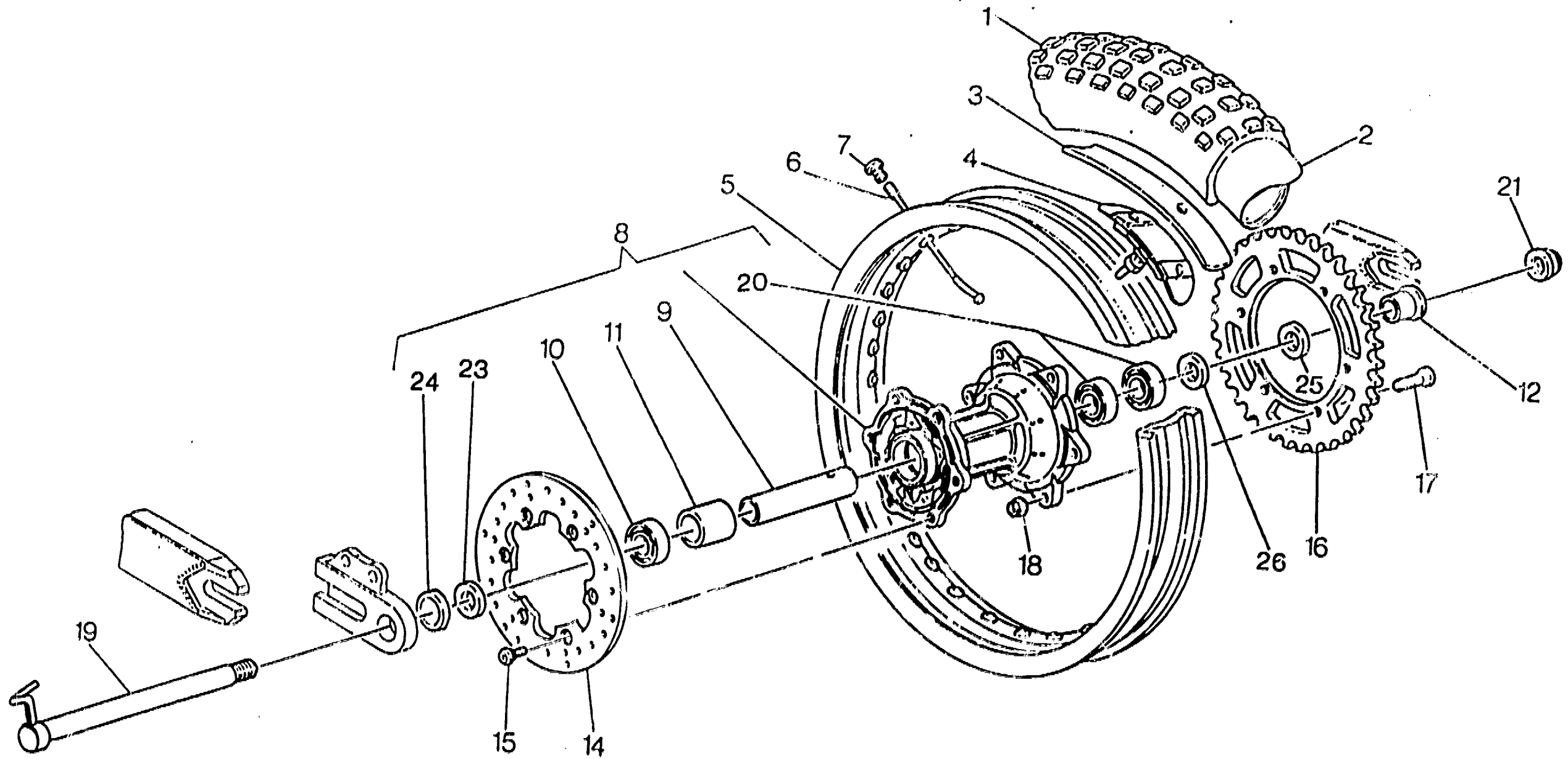



RUOTA POSTERIORE - REAR WHEEL
ROUE ARRIERE - HINTERRAD
RUEDA TRASERA

TAVOLA
DRAWING
TABLE
BILD
TABLA

23

TE - TC
610 / 95

Note Notes Marka Notas	Pos. No. Index Pos.	N. Cod. Code No. Nr. Code Code Nr N. Cod.	DENOMINAZIONE	NAME	DESIGNATION	BESHREIBUNG	DENOMINACION	Q.tà Q.ty Q.to M.ge C.ad	Validità Vaidlty Vaidné Gultig Valdez
■	16	8000 60065	Corona Z = 51	Ring gear	Couronne	Kranz	Corona	1	
■	16	8000 60066	Corona Z = 52	Ring gear	Couronne	Kranz	Corona	1	
□	16	8000 60062	Corona Z = 48	Ring gear	Couronne	Kranz	Corona	1	
□	16	8000 60063	Corona Z = 49	Ring gear	Couronne	Kranz	Corona	1	
□	16	8000 60064	Corona Z = 50	Ring gear	Couronne	Kranz	Corona	1	
□	16	8000 60065	Corona Z = 51	Ring gear	Couronne	Kranz	Corona	1	
	17	8000 40796	Vite	Screw	Vis	Schraube	Tomillo	6	
	18	8000 43928	Dado	Nut	Ecrou	Mutter	Tuerca	6	
◇	19	8A00 72621	Perno	Pin	Pivot	Bolzen	Perno	1	
◇	19	8C00 72621	Perno	Pin	Pivot	Bolzen	Perno	1	
	20	8000 39651	Cuscinetto	Bearing	Roulement	Kugellager	Cojinete	2	
	21	8000 64301	Dado	Nut	Ecrou	Mutter	Tuerca	1	
	23	8000 69163	Anello di tenuta	Seal ring	Bague d'étanchéité	Dichtungsring	Anillo de retención	1	
	24	8000 69164	Distanziale	Spacer	Entretoise	Distanzstück	Separador	1	
	25	8000 64863	Ghiera	Ring nut	Embout	Nutmutter	Virola	1	
	26	8000 36357	Anello di tenuta	Seal ring	Bague d'étanchéité	Dichtungsring	Anillo de retención	1	
			◆ = Non fornito	◆ = Not supplied	◆ = Ne pas fournir	◆ = Nicht versorgt	◆ = Sin fornitura		
			■ = A richiesta Modello TE	■ = Upon request TE model	■ = Sur demande Modèle TE	■ = Auf Anfrage Modell TE	■ = Bajo pedido Modelo TE		
			□ = A richiesta Modello TC	□ = Upon request TC model	□ = Sur demande Modèle TC	□ = Auf Anfrage Modell TC	□ = Bajo pedido Modelo TC		
			★ = Modello TE	★ = TE model	★ = Modèle TE	★ = Modell TE	★ = Modelo TE		
			☆ = Modello TC	☆ = TC modell	☆ = Modèle TC	☆ = Modell TC	☆ = Modelo TC		
			◇ = In alternativa	◇ = In alternative	◇ = En alternative	◇ = Die Auswahl	◇ = En alternativa		

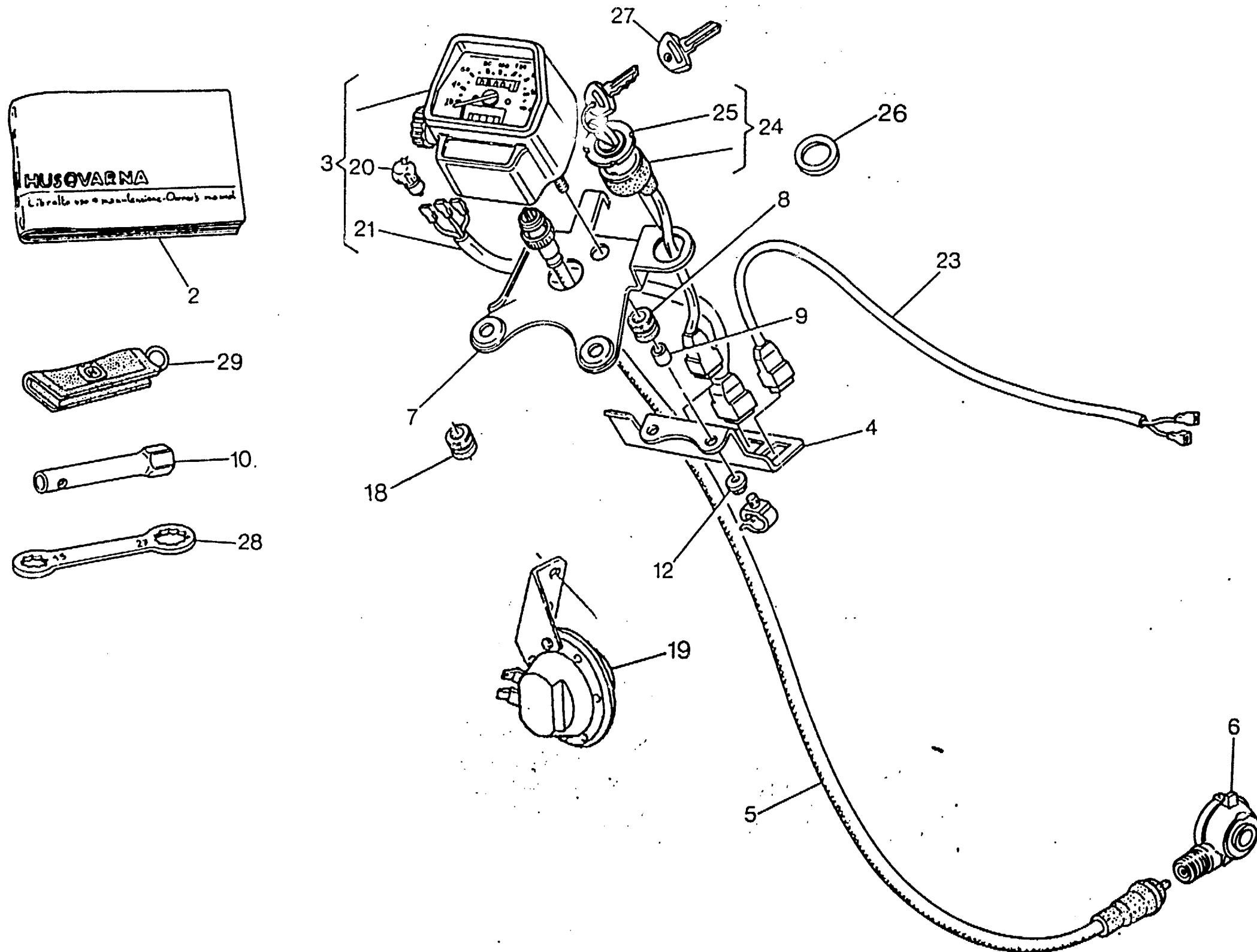



CONTACHILOMETRI, LIBRETTO USO MANUTENZIONE, AVV. ACUSTICO - SPEEDOMETER, OWNER'S MANUAL, HORN
 COMPTE-KILOMETRES, EMPLOI D'ENTRETIEN, SIGNAL ACOUSTIQUE - TACHOMETER, BETRIEBSANLEITUNG,
 BREMSSCHEIBESCHUTZ, HUPE - CUENTA-KILOMETROS, FOLLETO DE INSTRUCCIONES, AVISADOR ACUSTICO

TAVOLA
DRAWING
TABLE
BILD
TABLA

24

TE - TC
610 / 95

Note Notes Notas	Pos. No. Index Pos.	N. Cod. Code No. Nr. Code Code Nr N. Cod.	DENOMINAZIONE	NAME	DESIGNATION	BESHREIBUNG	DENOMINACION	Q.tà Q.ty Q.tie M.ge C.ad	Validà Validty Validé Gültig Valdez
	2	8000 79880	Libretto uso e manutenzione	Owner's manual	Emploi d'entretien	Betriebsanleitung	Manual de uso y mantenimiento	1	
★	3	8000 67209	Ass. contachilometri	Speedometer assy	Compteur-km. compl.	Tachometer kpl.	Cuenta-kilómetros compl.	1	
★	4	8000 69428	Piastra	Plate	Plaque	Platte	Placa	1	
★	5	8800 71759	Trasmissione contachilometri	Speedometer cable	Câble compteur - km	Tachokabel	Cable cuenta-kilómetros	1	
★	6	8000 77827	Rinvio contachilometri	Odometer transm.	Renvoi compte-km.	Vorgelege Kilometerzähler	Reenvío cuenta-kilómetros	1	
★	7	8000 69978	Piastra	Plate	Plaque	Platte	Placa	1	
★	8	8000 62651	Antivibrante	Silent-block	Antivibration	Schwingungsdämpfer	Anti-vibrador	2	
★	9	8000 25053	Distanziale	Spacer	Entretoise	Distanzstück	Separador	2	
	10	1619698-01	Chiave candela	Spark plug wrench	Clé bougie	Zündkerzeschlüssel	Llave bujía	1	
★	12	8000 61313	Dado	Nut	Ecrou	Mutter	Tuerca	2	
★	18	8000 72648	Gommino	Rubber pad	Pièce caoutchouc	Gummistück	Junta de goma	1	
★	19	8000 79759	Avvisatore acustico	Horn	Signal acoustique	Hupe	Avisador acústico	1	
★	20	8000 20602	Lampadina	Lamp	Lampe	Lampe	Lamparilla	5	
★	21	8000 67204	Cavi	Cable	Cable	Kabel	Cable	1	
★	23	8000 75477	Cavi	Cable	Cable	Kabel	Cable	1	
★	24	8000 74259	Interr. accensione completo	Ignition switch assy	Interrupteur pour allum. comp.	Schalter, Kpl.	Interruptor encendido compl.	1	
★	25	8000 74258	Ghiera	Ring nut	Embout	Nutmutter	Virola	1	
★	26	8000 50569	Distanziale	Spacer	Entretoise	Distanzstück	Separador	1	
★	27	8000 38210	Chiave grezza	Raw kei	Cléf primitive	Schlüssel	Llave greggia	1	
★	28	8000 66802	Chiave poligonale	Box wrench	Clé polygonale	Sechskantschlüssel	Llave poligonal	1	
★	29	8000 72037	Porta chiavi (in dotazione)	Key-ring (to issue)	Porte-clefs (en necessaire)	Schlüsselring (ausrüstungsteile)	Llavero (en dotacion)	1	
			★ = Modello TE	★ = TE model	★ = Modèle TE	★ = Modell TE	★ = Modelo TE		

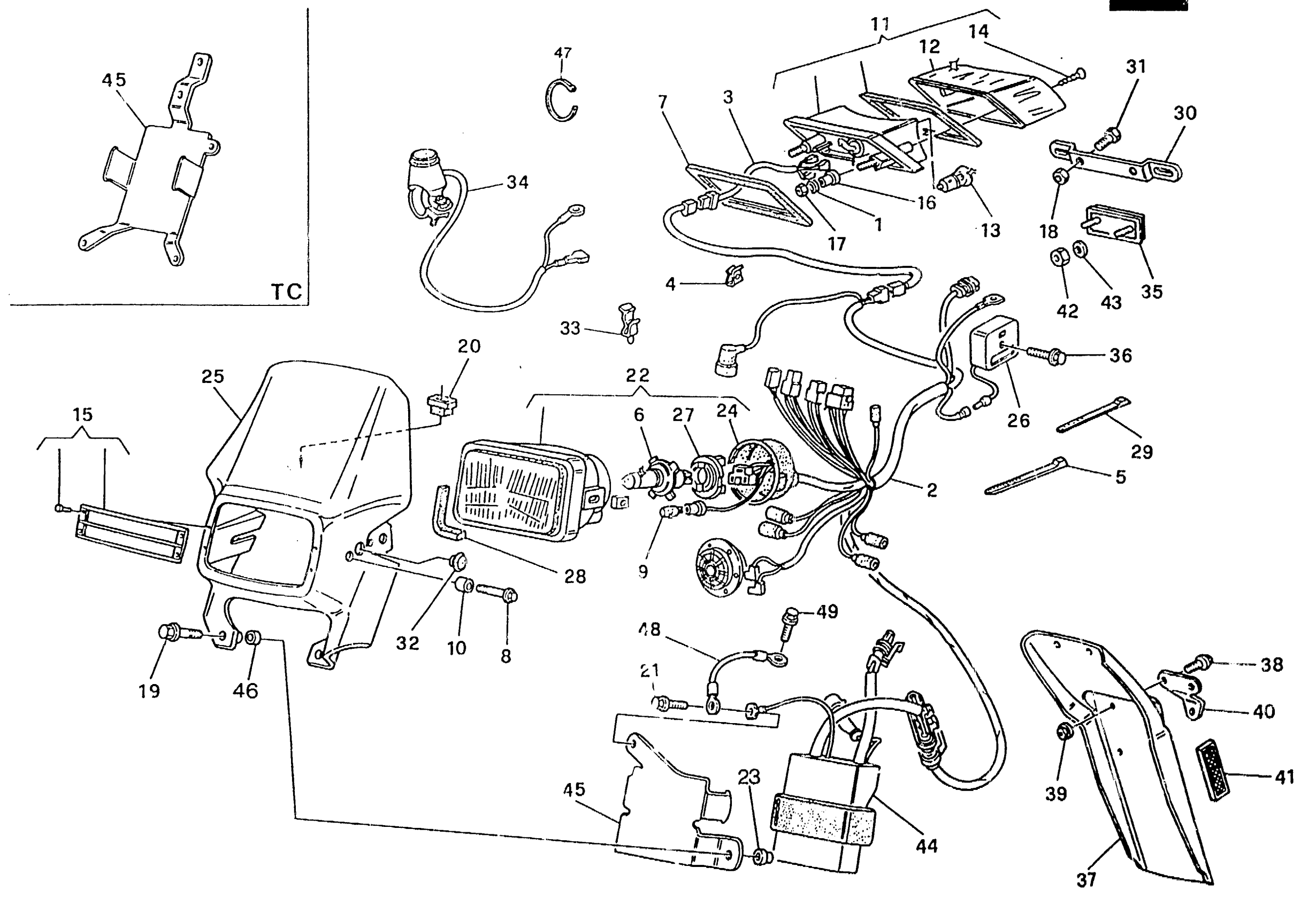



IMPIANTO ELETTRICO, PORTATARGA, PORTANUMERO - ELECTRIC SYS., PLATE HOLDER, NUMBER HOLDER
 INSTALLATION ELECT., PORTE-BALAI, PORTE-NOMBRE - ELEK. ANLAGE, SCHILDTRAEGER, NUMMERTRAGER
 INSTALAC. ELECT., PORTA-MATRICULA, PORTA NUMERO

TAVOLA
 DRAWING
 TABLE
 BILD
 TABLA

25

TE - TC
 610 / 95

Note Notes Marka Notas	Pos. No. N. Index Pos.	N. Cod. Code No. Nr. Code Code Nr N. Cod.	DENOMINAZIONE	NAME	DESIGNATION	BESCHREIBUNG	DENOMINACION	Q.tà Q.ty Q.té M.ge C.ad	Validità Validity Validez Gültig Validez
★	1	62N1 15549	Rosetta piana	Washer	Rondelle	Scheibe	Arandela	2	
★	2	8000 79758	Gruppo principale cavi	Cable assy	Cables compl.	Kabel Kpl.	Grupo principal cables	1	
☆	2	8000 80142	Gruppo principale cavi	Cable assy	Cables compl.	Kabel Kpl.	Grupo principal cables	1	
★	3	8000 70277	Cavo posteriore	Cable	Cable	Kabel	Cable	1	
★	4	8000 72494	Passacavo	Fairlead	Passe-câble	Kabelführung	Prensa-cable	1	
★	5	8000 34002	Fascetta	Clamp	Collier	Schelle	Banda	5	
★	6	8000 42946	Lampada	Lamp	Lampe	Lampe	Lamparilla	1	
★	6	8000 46445	Lampada (F)	Lamp (F)	Lampe (F)	Lampe (F)	Lamparilla (F)	1	
★	7	8000 66479	Guarnizione	Gasket	Garniture	Dichtung	Junta	1	
★	8	8000 62727	Vite	Screw	Vis	Schraube	Tornillo	2	
★	9	8000 36727	Lampada	Lamp	Lampe	Lampe	Lamparilla	1	
★	10	8000 70826	Distanziale	Spacer	Entretoise	Distanzstück	Separador	2	
★	11	8000 65555	Fanale posteriore completo	Tail light	Feux arrière	Hinterleuchte	Faro trasero	1	
★	12	8000 66480	Lente	Lens	Loupe	Linse	Lente	1	
★	13	8000 18246	Lampada	Lamp	Lampe	Lampe	Lamparilla	1	
★	14	8000 66482	Vite	Screw	Vis	Schraube	Tornillo	2	
★	15	8000 76290	Kit protezione	Kit guard	Kit protection	Kit Schutz	Kit protección	1	
★	16	8000 62416	Distanziale	Spacer	Entretoise	Distanzstück	Separador	2	
★	17	8000 44240	Dado	Nut	Ecrou	Mutter	Tuerca	2	
★	18	8000 44240	Dado	Nut	Ecrou	Mutter	Tuerca	2	
★	19	8000 62730	Vite	Screw	Vis	Schraube	Tornillo	2	
★	20	8000 50808	Gommino	Rubber pad	Pièce caoutchouc	Gummistück	Junta de goma	2	
	21	8000 62725	Vite	Screw	Vis	Schraube	Tornillo	1	
★	22	8000 70280	Gruppo ottico completo	Optical group	Groupe optique	Optische Gruppe	Grupo óptico	1	
★	23	8000 70034	Distanziale	Spacer	Entretoise	Distanzstück	Separador	2	
★	24	8000 70282	Cuffia in gomma	Boot	Poussière	Gummihaube	Gorro de protección en goma	1	



IMPIANTO ELETTRICO, PORTATARGA, PORTANUMERO - ELECTRIC SYS., PLATE HOLDER, NUMBER HOLDER
 INSTALLATION ELECT., PORTE-BALAI, PORTE-NOMBRE - ELEK. ANLAGE, SCHILDTRAEGER, NUMMERTRAGER
 INSTALAC. ELECT., PORTA-MATRICULA, PORTA NUMERO

TAVOLA
DRAWING
TABLE
BILD
TABLA

25

TE - TC
610 / 95

Note Notes Marka Notas	Pos. No. N. Index Pos.	N. Cod. Code No. Nr. Code Code Nr N. Cod.	DENOMINAZIONE	NAME	DESIGNATION	BESCHREIBUNG	DENOMINACION	Q.tà Q.ty Q.te M.ge C.ad	Validità Validity Validité Gültig Validez
★	25	8AF0 69480	Cupolino	Fairing	Carenage	Verkleidung	Cúpula	1	
★	26	8000 79571	Regolatore di tensione	Voltage rectifier	Régulateur de tension	Spannungsregler	Regulador de tensión	1	
★	27	8000 42926	Portalamпада	Lamp holder	Douille	Lampenfassung	Porta-lamparilla	1	
★	28	8000 70283	Guarnizione	Gasket	Garniture	Dichtung	Junta	1	
★	29	8000 56444	Fascetta	Clamp	Collier	Schelle	Banda	10	
★	30	8A00 66223	Staffa	Bracket	Etrier	Buegel	Brida	1	
★	31	8000 62727	Vite	Screw	Vis	Schraube	Tornillo	2	
★	32	8B00 55101	Tappo	Plug	Bouchon	Verschluss	Tapón	2	
★	33	8000 58207	Passacavo	Fairlead	Passe-câble	Kabelführung	Prensa-cable	1	
☆	34	8000 65391	Pulsante «Engine Stop»	«Engine Stop» button	Bouton «Engine Stop»	Drucktaste «Engine Stop»	Pulsador «Engine Stop»	1	
★	35	8000 73834	Catadiottro	Reflector	Catadioptrique	Ruckstrahler	Catafaros	1	
★	36	8000 62730	Vite	Screw	Vis	Schraube	Tornillo	1	
★	37	8000 70239	Paraspruzzi (CH - D)	Rear end (CH - D)	Terminal (CH - D)	Hinterkiff (CH - D)	Para rociada (CH - D)	1	
★	38	8000 62726	Vite (CH - D)	Screw (CH - D)	Vis (CH - D)	Schraube (CH - D)	Tornillo (CH - D)	2	
★	39	8000 44240	Dado (CH - D)	Nut (CH - D)	Ecrou (CH - D)	Mutter (CH - D)	Tuerca (CH - D)	2	
★	40	8000 70279	Piastra (D)	Plate (D)	Plaque (D)	Platte (D)	Placa (D)	1	
★	41	8000 45436	Catadiottro (D)	Reflector (D)	Catadioptrique (D)	Ruckstrahler (D)	Catafaros (D)	2	
★	42	8000 40717	Dado	Nut	Ecrou	Mutter	Tuerca	2	
★	43	62N1 15547	Rosetta	Washer	Rondelle	Scheibe	Arandela	2	
★	44	8000 77393	Centralina elettronica	Electronic device	Dispositif électronique	Zündelektronik	Centralita electrónica	1	
★	45	8000 79766	Piastra	Plate	Plaque	Platte	Placa	1	
☆	45	8000 79767	Piastra	Plate	Plaque	Platte	Placa	1	
★	46	8A00 69429	Bussola	Bushing	Douille	Buchse	Manguito	2	
★	47	8000 71578	Fascetta	Clamp	Collier	Schelle	Banda	2	
★	48	8000 84139	Cavetto di massa	Cable	Cable	Kabel	Cable	1	
☆	49	60N1 01076	Vite	Screw	Vis	Schraube	Tornillo	1	

★ = Modello TE
☆ = Modello TC

★ = TE model
☆ = TC model

★ = Modèle TE
☆ = Modèle TC

★ = Modell TE
☆ = Modell TC

★ = Modelo TE
☆ = Modelo TC

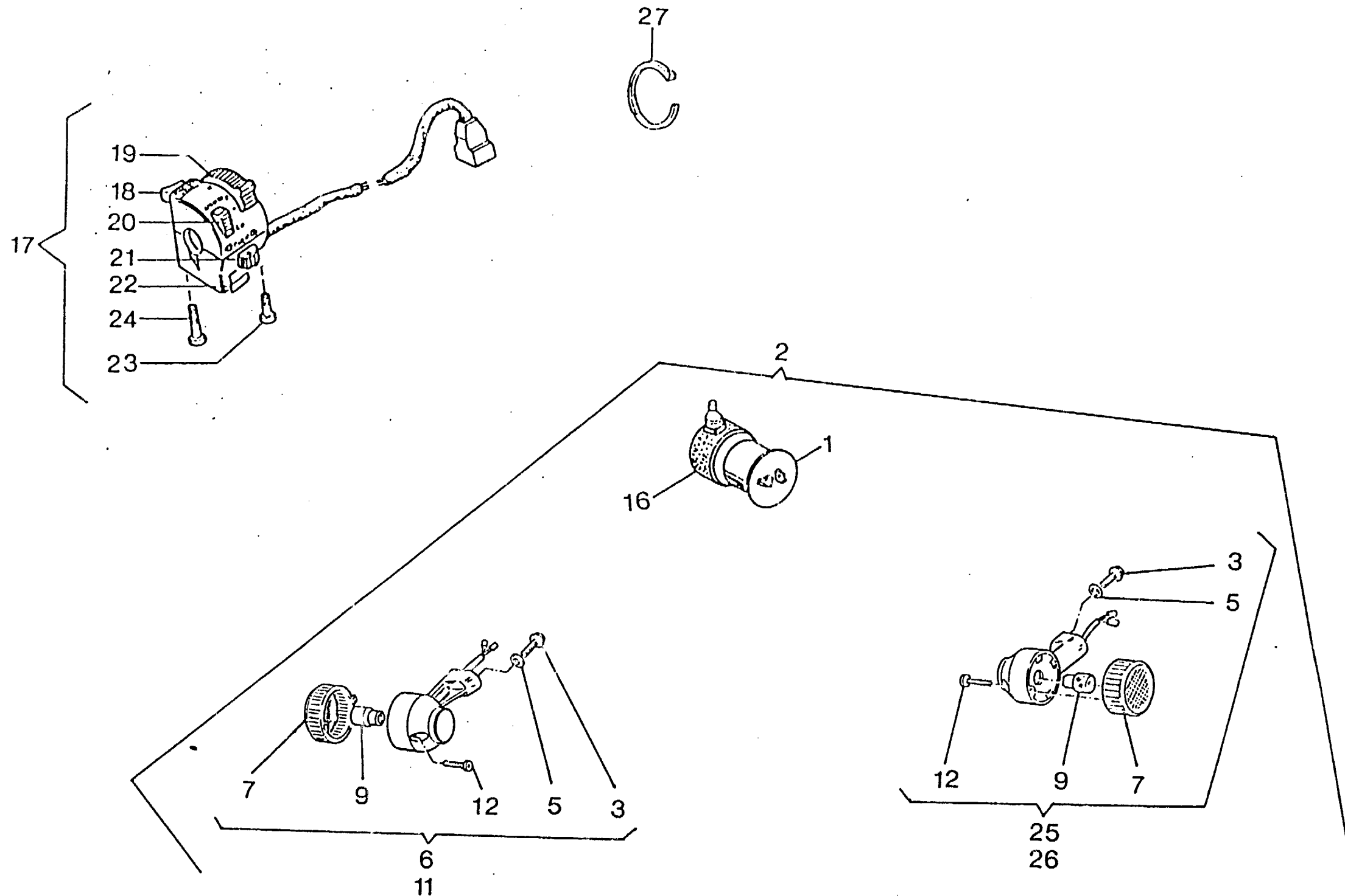



FRECCE - BLINKER
CLIGNOTANT - BLINKER
INTERMITENTE

(TE)

TAVOLA
DRAWING
TABLE
BILD
TABLA

26

TE - TC
610 / 95

Note Notes Marka Notas	Pos. No. Index Pos.	N. Cod. Code No. Nr. Code Code Nr N. Cod.	DENOMINAZIONE	NAME	DESIGNATION	BESHREIBUNG	DENOMINACION	Q.tà Q.ty Q.te M.ge C.ad	Validità Validity Valditë Gültig Validez
▲	1	8000 57511	Intermittenza	Flash device	Intermittence	Blinkgeber	Intermitencia	1	
▲	2	3000 73588	Kit indicatori di direzione	Blinker kit	Gr. clignotant	Blinker Gruppe	Kit intermitente	1	
▲	3	8000 62726	Vite	Screw	Vis	Schraube	Tornillo	4	
▲	5	8000 48814	Rosetta piana	Washer	Rondelle	Scheibe	Arandela	4	
▲	6	8A00 73589	Indicatore anteriore dx.	Blinker	Clignotant	Blinker	Intermitente	1	
▲	7	8000 73591	Lente	Lens	Loupe	Linse	Lente	4	
▲	9	8000 36726	Lampada 12V - 10W	Lamp	Lampe	Lampe	Lamparilla	4	
▲	11	8000 73589	Indicatore anteriore sx.	Blinker	Clignotant	Blinker	Intermitente	1	
▲	12	8000 73592	Vite	Screw	Vis	Schraube	Tornillo	4	
▲	16	8000 37599	Supporto elastico	Support	Support	Halterung	Soporte	1	
	17	8A00 69692	Commutatore compl.	Switch compl.	Commutateur compl.	Kombischalter kpl.	Conmutador compl.	1	
▲	25	8A00 73590	Indicatore posteriore dx.	Blinker	Clignotant	Blinker	Intermitente	1	
▲	26	8000 73590	Indicatore posteriore sx.	Blinker	Clignotant	Blinker	Intermitente	1	
	27	8000 71578	Fascetta	Clamp	Collier	Schelle	Banda	2	
			▲ = A richiesta	▲ = Upon request	▲ = Sur demande	▲ = Auf Anfrage	▲ = Bajo pedido		

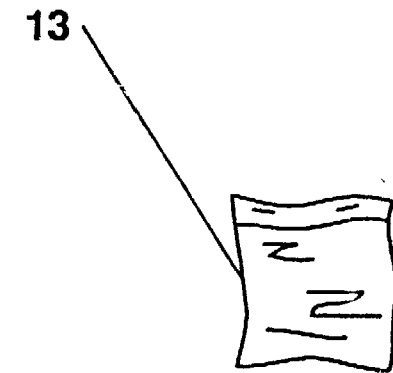
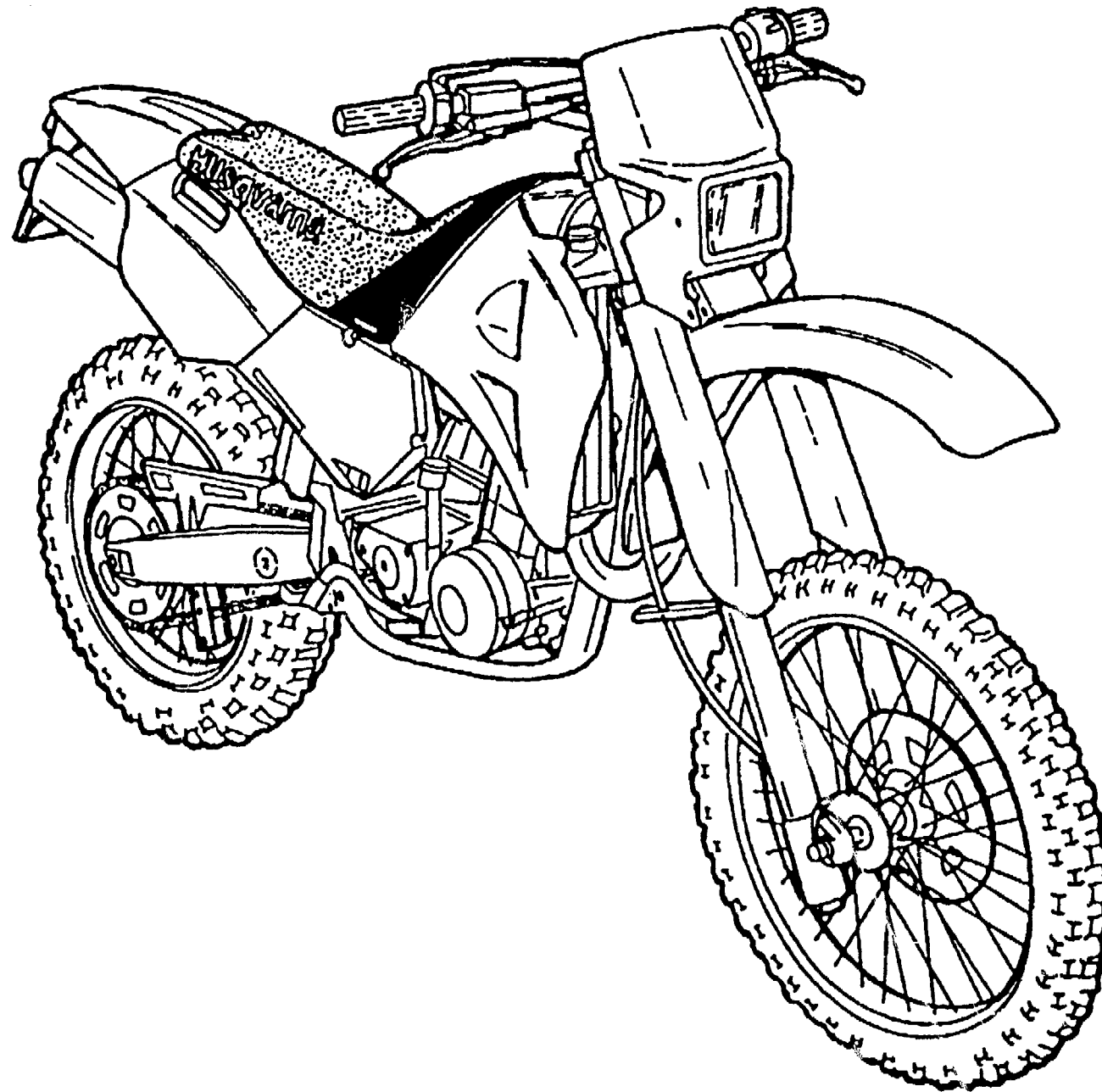
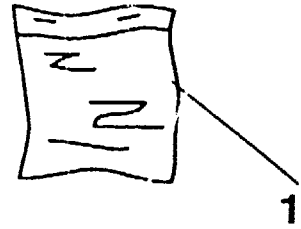



DECALCOMANIE - TRANSFER
DACALCOMANIE - ABZIEHBILD
CALCOMANIA

(TE)

TAVOLA
DRAWING
TABLE
BILD
TABLA

27

TE - TC
610 / 95

Note Notes Marka Notas	Pcs. No. N. Index Pos.	N. Cod. Code No. Nr. Code Code Nr N. Cod.	DENOMINAZIONE	NAME	DESIGNATION	BESHREIBUNG	DENOMINACION	Q.tà Q.ty Q.té M.ge C.ad	Validità Validité Validé Gültig Validez
	1	8000 79861	Kit adesivi	Trims kit	Gr. décal.	Hinterabziehbild Gruppe	Kit adhesivo	1	
	12	8A00 75413	Kit adesivi portanumeri rossi (a richiesta)	Trims kit number holder red (upon request)	Gr. décal. porte numero rouge (sur demande)	Hinterabz. Gr.Nummerhalter rot (Auf Anfrage)	Kit adhesivo portanúmero rojo (bajo pedido)	1	
	13	8000 75413	Kit adesivi portanumeri gialli (a richiesta)	Trims kit number holder yellow (upon request)	Gr. décal. porte numero jaune (sur demande)	Hinterabz. Gr.Nummerhalter gelb (Auf Anfrage)	Kit adhesivo portanúmero amarillo (bajo pedido)	1	

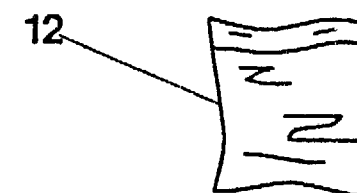
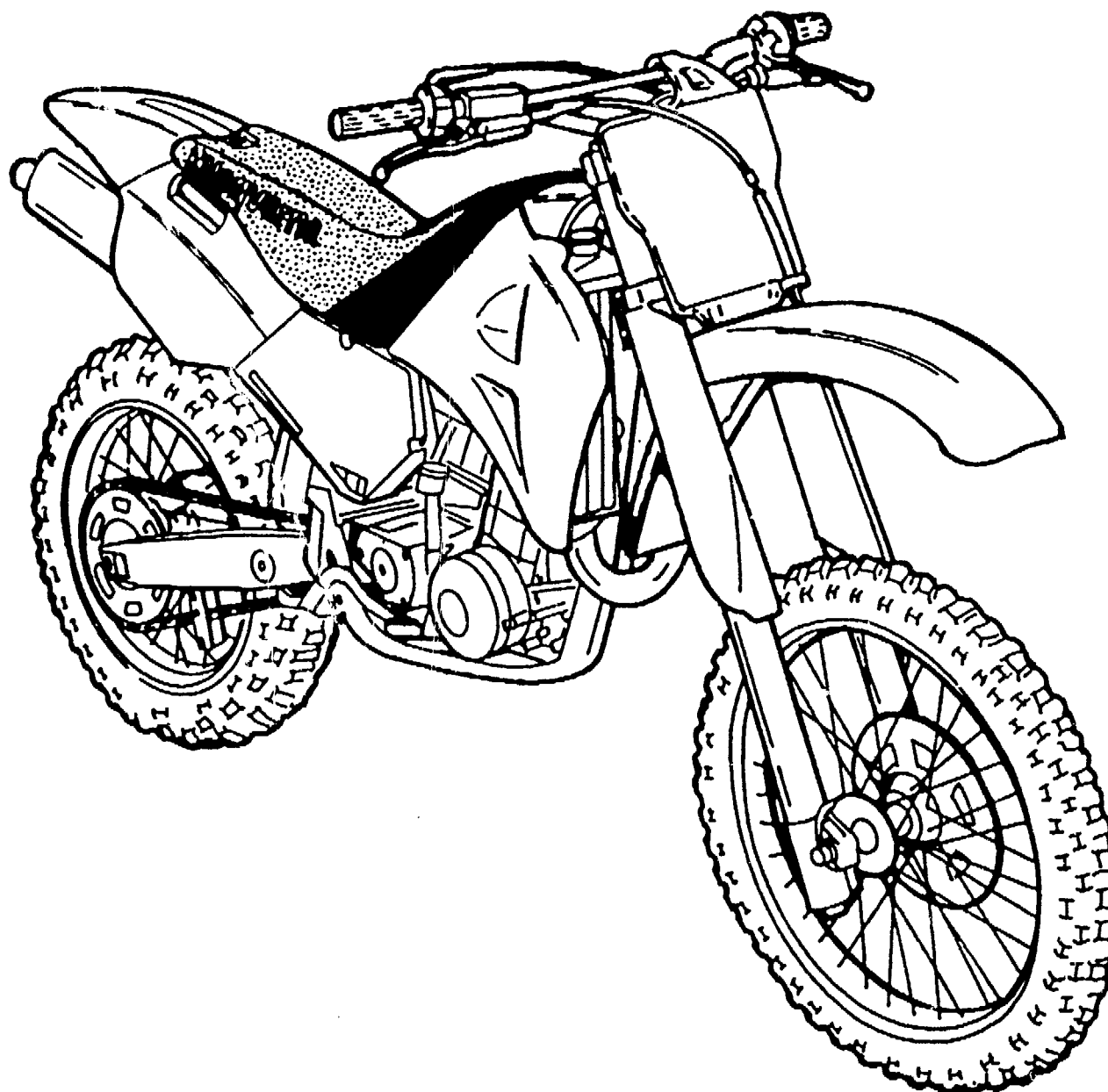
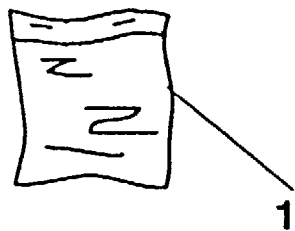



DECALCOMANIE - TRANSFER
DACALCOMANIE - ABZIEHBILD
CALCOMANIA

(TC)

TAVOLA
DRAWING
TABLE
BILD
TABLA

28

TE - TC
610 / 95

Note Notes Marka Notas	Pos. No. Index Pos.	N. Cod. Code No. Nr. Code Code Nr N. Cod.	DENOMINAZIONE	NAME	DESIGNATION	BESHREIBUNG	DENOMINACION	Q.tà Q.ty Q.té M.ge C.ad	Validità Validity Valdité Gultig Validez
	1	8800 80187	Kit adesivi	Trims kit	Gr. décal.	Hinterabziehbild Gruppe	Kit adhesivo	1	
	12	8000 75040	Kit adesivi portanumeri gialli (a richiesta)	Trims kit number holder yellow (upon request)	Gr. décal. porte numero jaune (sur demande)	Hinterabz. Gr.Nummerhalter gelb (Auf Anfrage)	Kit adhesivo portanúmero amarillo (bajo pedido)	1	

DISEGNO DRAWING DESSIN ZEICHNUNG DIBUJO	TAVOLA DRAWING TABLE BILD TABLA	INDEX NO. POS. N. INDICE	DISEGNO DRAWING DESSIN ZEICHNUNG DIBUJO	TAVOLA DRAWING TABLE BILD TABLA	INDEX NO. POS. N. INDICE	DISEGNO DRAWING DESSIN ZEICHNUNG DIBUJO	TAVOLA DRAWING TABLE BILD TABLA	INDEX NO. POS. N. INDICE	DISEGNO DRAWING DESSIN ZEICHNUNG DIBUJO	TAVOLA DRAWING TABLE BILD TABLA	INDEX NO. POS. N. INDICE	DISEGNO DRAWING DESSIN ZEICHNUNG DIBUJO	TAVOLA DRAWING TABLE BILD TABLA	INDEX NO. POS. N. INDICE
6BN0 21509	8	15	8A00 67740	4	19	8B00 67997	13	44	8Q00 27910	10	2	61N1 15062	8	8
6BN0 21509	8A	4	8A00 67932	10	43	8B00 69282	19	25	8Q00 27910	10A	2	61N1 15062	8A	39
8A00 15960	2	47	8A00 67997	14	23	8B00 70208	19	9	60N1 01076	25	49	61N1 15062	18	27
8A00 15960	3	34	8A00 68196	6	30	8BC0 71027	4	17	60N10 1048	10	55	61N1 15195	2	1
8A00 18648	22A	2	8A00 68201	6	28	8B00 71233	21	1	60N10 1048	10A	55	61N1 15195	3	22
8A00 28183	4	2	8A00 69056	14	51	8B00 71234	21	2	60N10 1079	7	25	61N4 15192	13	24
8A00 33607	23	2	8A00 69138	16	13	8B00 71759	24	5	60N10 1081	8	17	62N1 15503	10	57
8A00 35794	3	5	8A00 69282	14	57	8B00 77741	22	11	60N10 1081	8A	28	62N1 15503	10A	57
8A00 36022	6	38	8A00 69285	16	4	8B00 80187	28	1	60N10 1219	13	15	62N1 15504	3	36
8A00 38350	8	52	8A00 69429	25	46	8E00 82861	8	11	60N10 2487	9	8	62N1 15504	6	9
8A00 38350	8A	57	8A00 69692	26	17	8B00 82861	8A	32	60N10 2504	7	75	62N1 15504	12	35
8A00 40877	10	51	8A00 69774	6	35	8C00 24058	10	3	60N10 2510	2	34	62N1 15507	12	5
8A00 40877	10A	51	8A00 69774	7	12	8C00 24058	10A	3	60N10 2510	6	15	62N1 15519	5	28
8A00 48137	8	10	8A00 69782	11	1	8C00 28183	4	2	60N10 2510	7	50	62N1 15524	14	5
8A00 48137	8A	34	8A00 70266	18	20	8C00 36022	6	38	60N10 2511	2	40	62N1 15547	5	35
8A00 48188	6	1	8A00 72284	5	32	8C00 50322	3	47	60N10 2511	3	32	62N1 15547	25	43
8A00 50322	3	47	8A00 72411	21	8	8C00 61121	14	20	60N10 2511	18	26	62N1 15549	25	1
8A00 55241	22A	17	8A00 72621	23	19	8C00 61348	23	1	60N10 2511	21	3	62N1 15567	3	37
8A00 55532	6	2	8A00 73589	26	6	8C00 67422	22A	1	60N10 2512	7	47	62N1 15658	3	6
8A00 55858	23	14	8A00 73590	26	25	8C00 67545	19	20	60N10 2513	3	26	62N1 15780	18	2
8A00 59802	20A	12	8A00 74181	22	20	8C00 67997	9	11	60N10 2513	6	6	62N4 15548	9	13
8A00 59964	9	2	8A00 74718	22A	11	8C00 67997	13	21	60N10 2513	7	54	64N1 20048	12	36
8A00 60415	2	51	8A00 75042	22A	18	8C00 67997	19	28	60N10 2513	9	6	64N1 20068	12	8
8A00 60652	11	19	8A00 75153	16	3	8C00 69112	12	15	60N10 2514	3	31	64N1 20068	18	7
8A00 61348	23	1	8A00 75413	27	12	8C00 70034	25	23	60N10 2515	6	13	66N0 21205	7	31
8A00 62129	22A	23	8A00 75764	7	44	8C00 72621	23	19	60N10 2517	3	30	66N0 21208	7	70
8A00 62797	12	28	8A00 76031	22	16	8C00 77741	22	11	60N10 2520	6	7	66N0 21211	6	21
8A00 62797	15	4	8A00 78765	2	31	8C00 79783	6	24	60N10 2525	5	6	66N0 21211	8	24
8A00 62797	16	17	8A00 79072	18	31	8D00 28183	4	2	60N10 2555	12	30	66N0 21211	8A	7
8A00 63644	2	43	8A00 79760	19	1	8D00 36022	6	38	60N10 2557	2	35	69N4 29004	22A	9
8A00 64708	18	1	8AA0 72564	12	6	8D00 79348	12	1	60N10 2866	7	16	69N4 29005	22A	9
8A00 64983	23	9	8AF0 69480	25	25	8D00 79785	6	24	60N10 2898	7	76	69N4 29005	23	7
8A00 65442	6	24	8AN0 12041	10	4	8E00 30053	8	29	60N10 2900	7	49	80A0 12032	10	6
8A00 65503	13	2	8B00 36022	6	38	8E00 30053	8A	20	60N10 2927	3	33	80A0 12032	10A	6
8A00 66223	25	30	8B00 38110	7	30	8E00 67545	19	11	60N10 4134	20	7	80A0 53018	17	14
8A00 66661	14	32	8B00 38752	20	12	8F00 10789	3	46	60N10 7330	17	9	80A0 60164	5	22
8A00 67216	7	55	8B00 42029	14	4	8F00 28183	4	2	60N10 7335	2	22	80A0 66202	14	17
8A00 67422	22A	1	8B00 42029	16	10	8F00 38110	7	30	60N10 7335	2	39	80A0 66222	2	50
8A00 67545	15	10	8B00 50322	3	47	8F00 56515	11	14	60N10 7335	7	69	80A0 66800	5	3
8A00 67545	20A	13	8B00 55101	25	32	8GA00 5761	10	5	60N10 7336	3	18	80A0 67186	5	1
8A00 67545	21	16	8B00 56768	6	24	8GA00 5761	10A	5	60N10 7350	20	15	80A0 67248	5	21
8A00 67545	21	16	8B00 65572	22A	22	8H00 28183	4	2	60N40 2489	13	23	80A0 67443	14	22

DISEGNO DRAWING DESSIN ZEICHNUNG DIBUJO	TAVOLA DRAWING TABLE BILD TABLA	INDEX NO. POS. N. INDICE	DISEGNO DRAWING DESSIN ZEICHNUNG DIBUJO	TAVOLA DRAWING TABLE BILD TABLA	INDEX NO. POS. N. INDICE	DISEGNO DRAWING DESSIN ZEICHNUNG DIBUJO	TAVOLA DRAWING TABLE BILD TABLA	INDEX NO. POS. N. INDICE	DISEGNO DRAWING DESSIN ZEICHNUNG DIBUJO	TAVOLA DRAWING TABLE BILD TABLA	INDEX NO. POS. N. INDICE	DISEGNO DRAWING DESSIN ZEICHNUNG DIBUJO	TAVOLA DRAWING TABLE BILD TABLA	INDEX NO. POS. N. INDICE
80A0 70218	15	6	8000 18246	25	13	8000 29665	10	8	8000 37745	20	10	8000 42473	8	14
80A0 72564	12	7	8000 18422	2	32	8000 29665	10A	8	8000 37891	18	35	8000 42473	8A	30
80A0 73426	14	16	8000 18648	22A	2	8000 30319	20	2	8000 37906	11	16	8000 42781	16	21
80A0 73456	14	15	8000 18922	20	16	8000 30326	8	36	8000 38110	7	30	8000 42926	25	27
80A0 74388	14	7	8000 18922	20A	11	8000 30326	8A	16	8000 38210	24	27	8000 42946	25	6
80A0 75671	11	9	8000 19609	6	12	8000 31271	7	66	8000 38748	20	13	8000 42955	10A	59
80A0 76687	17	15	8000 19768	6	25	8000 32065	16	22	8000 38767	16	15	8000 42980	10	53
80A0 76688	17	10	8000 19789	2	49	8000 32865	10	34	8000 38799	17	18	8000 42980	10A	53
80B0 40593	10A	56	8000 20536	14	14	8000 32865	10A	34	8000 38802	17	38	8000 43391	12	23
80B0 66630	20	1	8000 20536	14	41	8000 32866	10	52	8000 38956	16	8	8000 43714	5	2
80B0 69430	19	12	8000 20602	24	20	8000 32866	10A	32	8000 38957	16	9	8000 43715	5	4
80B0 70009	19	12	8000 21375	3	29	8000 32867	10	39	8000 39524	1	11	8000 43789	6	5
80B0 70209	19	10	8000 21480	6	20	8000 32867	10A	39	8000 39651	22A	13	8000 43928	12	10
80B0 73395	19	3	8000 21480	18	25	8000 33109	10	7	8000 39651	23	20	8000 43928	12	16
80B0 73396	19	26	8000 21480	22	15	8000 33109	10A	7	8000 39727	22	18	8000 43928	14	30
80B0 75766	2	24	8000 21535	8	16	8000 33211	10	41	8000 40449	7	29	8000 43928	14	56
80B0 84173	3	25	8000 21535	8A	29	8000 33211	10A	41	8000 40578	10	12	8000 43928	21	13
80B0 84174	3	16	8000 22466	10A	12	8000 33373	12	12	8000 40580	10	25	8000 43928	23	18
80C0 24058	10	60	8000 22551	18	3	8000 33607	23	2	8000 40580	10A	26	8000 44043	10	46
80C0 60559	9	5	8000 23110	6	37	8000 34002	25	5	8000 40584	10A	70	8000 44043	10A	46
80C00 5761	10	59	8000 23979	10	13	8000 35531	12	24	8000 40586	10A	58	8000 44240	5	5
80U0 12041	10A	4	8000 23979	10A	13	8000 35780	8	5	8000 40587	10A	69	8000 44240	11	11
8000 10777	23	3	8000 23981	10	9	8000 35780	8A	42	8000 40588	10A	64	8000 44240	14	33
8000 12029	10	22	8000 23981	10A	9	8000 35781	8	6	8000 40589	10A	67	8000 44240	14	53
8000 12029	10A	22	8000 23983	10	20	8000 35781	8A	41	8000 40590	10A	68	8000 44240	15	12
8000 12030	10	21	8000 23983	10A	20	8000 35823	8	35	8000 40591	10A	66	8000 44240	18	36
8000 12030	10A	21	8000 23985	10	16	8000 35823	8A	17	8000 40592	10A	65	8000 44240	19	4
8000 12033	10	18	8000 23985	10A	16	8000 36137	9	7	8000 40593	10A	61	8000 44240	19	13
8000 12033	10A	18	8000 23990	10	33	8000 36137	14	26	8000 40594	10A	62	8000 44240	20A	6
8000 12034	10	17	8000 23990	10A	33	8000 36137	14	31	8000 40595	10A	63	8000 44240	21	17
8000 12034	10A	17	8000 24319	2	48	8000 36357	23	26	8000 40597	10A	60	8000 44240	25	17
8000 12045	10	27	8000 25053	24	9	8000 36467	5	37	8000 40717	25	42	8000 44240	25	18
8000 12045	10A	27	8000 25647	14	58	8000 36726	26	9	8000 40796	23	17	8000 44240	25	39
8000 12046	10	28	8000 26970	7	20	8000 36727	25	9	8000 40813	20	17	8000 45183	6	19
8000 12046	10A	28	8000 27679	5	16	8000 36786	7	46	8000 41459	12	34	8000 45194	2	26
8000 12048	10	30	8000 27960	7	45	8000 36856	8	53	8000 41922	12	22	8000 45194	7	71
8000 12048	10A	30	8000 28182	6	4	8000 36856	8A	58	8000 41986	20A	17	8000 45436	13	43
8000 12451	10	50	8000 28182	7	2	8000 36857	8	51	8000 42022	15	5	8000 45436	25	41
8000 12451	10A	50	8000 28798	10	25	8000 36857	8A	59	8000 42022	16	18	8000 45490	19	5
8000 13346	22A	3	8000 28798	10A	25	8000 37283	5	34	8000 42023	16	12	8000 45495	5	31
8000 17810	14	21	8000 28799	10	24	8000 37299	3	20	8000 42278	2	21	8000 45495	11	17
8000 18048	19	8	8000 28799	10A	24	8000 37599	26	16	8000 42349	18	21	8000 45495	14	35

DISEGNO DRAWING DESSIN ZEICHNUNG DIBUJO	TAVOLA DRAWING TABLE B/D TABLA	INDEX NO. POS. N. INDICE	DISEGNO DRAWING DESSIN ZEICHNUNG DIBUJO	TAVOLA DRAWING TABLE BILD TABLA	INDEX NO. POS. N. INDICE	DISEGNO DRAWING DESSIN ZEICHNUNG DIBUJO	TAVOLA DRAWING TABLE BILD TABLA	INDEX NO. POS. N. INDICE	DISEGNO DRAWING DESSIN ZEICHNUNG DIBUJO	TAVOLA DRAWING TABLE BILD TABLA	INDEX NO. POS. N. INDICE	DISEGNO DRAWING DESSIN ZEICHNUNG DIBUJO	TAVOLA DRAWING TABLE BILD TABLA	INDEX NO. POS. N. INDICE
8000 45495	19	22	8000 55902	18	4	8000 60062	23	16	8000 61064	23	11	8000 62731	14	29
8000 45499	21	4	8000 55903	18	13	8000 60062	23	16	8000 61068	13	3	8000 62731	14	52
8000 46445	25	6	8000 56359	15	11	8000 60063	23	16	8000 61078	18	14	8000 62733	13	18
8000 46510	13	62	8000 56359	19	32	8000 60063	23	16	8000 61136	13	49	8000 62733	22	21
8000 46511	13	63	8000 56377	18	6	8000 60064	23	16	8000 61263	7	5	8000 62795	14	8
8000 46881	3	38	8000 56381	20	4	8000 60064	23	16	8000 61269	7	74	8000 62796	12	14
8000 46893	11	8	8000 56410	6	31	8000 60065	23	16	8000 61275	4	18	8000 62796	13	7
8000 46893	15	8	8000 56443	13	22	8000 60065	23	16	8000 61313	24	12	8000 63312	12	20
8000 47708	2	20	8000 56444	25	29	8000 60066	23	16	8000 61314	13	16	8000 63312	14	36
8000 47763	7	53	8000 56767	6	23	8000 60066	23	16	8000 61362	20	9	8000 63424	8	42
8000 47824	17	17	8000 56806	11	21	8000 60196	23	2	8000 61752	23	1	8000 63425	8	9
8000 48138	8	13	8000 57155	18	24	8000 60233	13	12	8000 62416	25	16	8000 63425	8A	56
8000 48138	8A	31	8000 57155	18	35	8000 60234	13	13	8000 62651	24	8	8000 63432	8A	5
8000 48772	22A	20	8000 57155	22	14	8000 60404	18	34	8000 62675	14	45	8000 63798	8A	53
8000 48773	22A	19	8000 57242	5	13	8000 60463	8	45	8000 62676	14	46	8000 63817	2	9
8000 48814	26	5	8000 57413	10	45	8000 60464	6	36	8000 62725	5	10	8000 63821	8	26
8000 48916	17	19	8000 57413	10A	45	8000 60470	8	55	8000 62725	5	26	8000 63822	8	56
8000 48918	17	35	8000 57511	26	1	8000 60472	7	72	8000 62725	5	27	8000 63827	6	22
8000 49036	22A	4	8000 58140	7	68	8000 60472	8	38	8000 62725	14	54	8000 63829	6	22
8000 49654	22	6	8000 58207	25	33	8000 60472	8A	14	8000 62725	20	18	8000 63832	6	22
8000 50217	23	4	8000 58929	23	5	8000 60473	8	37	8000 62725	20A	8	8000 64301	23	21
8000 50322	3	47	8000 59289	14	24	8000 60473	8A	15	8000 62725	20A	9	8000 64591	14	13
8000 50569	24	26	8000 59289	14	39	8000 60474	7	40	8000 62725	25	21	8000 64726	2	5
8000 50808	25	20	8000 59433	12	19	8000 60475	7	36	8000 62726	18	12	8000 64863	23	25
8000 51957	22A	15	8000 59434	12	21	8000 60476	7	6	8000 62726	25	38	8000 64886	23	5
8000 53155	13	14	8000 59540	4	20	8000 60477	7	57	8000 62726	26	3	8000 64985	23	12
8000 53259	18	32	8000 59801	5	9	8000 60479	10	1	8000 62727	5	25	8000 64988	3	39
8000 53259	22	24	8000 59801	20A	4	8000 60480	10	11	8000 62727	11	2	8000 65391	25	34
8000 53339	2	38	8000 59802	5	7	8000 60480	10A	11	8000 62727	12	33	8000 65411	14	38
8000 53340	7	41	8000 59802	20A	3	8000 60501	10	38	8000 62727	15	7	8000 65412	14	37
8000 53504	22A	6	8000 59803	5	8	8000 60501	10A	38	8000 62727	18	18	8000 65437	17	34
8000 53724	18	19	8000 59803	20A	2	8000 60502	10	36	8000 62727	19	14	8000 65464	6	23
8000 54073	23	4	8000 59839	16	5	8000 60502	10A	36	8000 62727	25	8	8000 65555	25	11
8000 54274	17	14	8000 59939	3	14	8000 60504	10	42	8000 62727	25	31	8000 65604	20	3
8000 54477	8	4	8000 59940	2	36	8000 60525	8A	55	8000 62728	11	20	8000 65653	6	16
8000 54477	8A	43	8000 59941	3	35	8000 60526	8A	1	8000 62728	17	29	8000 66101	7	52
8000 54692	8	7	8000 59942	2	28	8000 60558	2	33	8000 62728	19	14	8000 66111	12	11
8000 54692	8A	40	8000 59965	8	2	8000 60577	7	63	8000 62728	20A	5	8000 66196	14	2
8000 55101	11	3	8000 59965	8A	45	8000 60873	5	23	8000 62729	13	19	8000 66238	20	8
8000 55241	19	30	8000 59975	7	3	8000 60925	5	29	8000 62730	19	18	8000 66281	6	18
8000 55876	23	10	8000 59976	7	4	8000 60925	5	30	8000 62730	25	19	8000 66395	2	45
8000 55878	23	15	8000 59977	6	17	8000 60925	20A	7	8000 62730	25	36	8000 66405	7	77

DISEGNO DRAWING DESSIN ZEICHNUNG DIBUJO	TAVOLA DRAWING TABLE BILD TABLA	INDEX NO. POS. N. INDICE	DISEGNO DRAWING DESSIN ZEICHNUNG DIBUJO	TAVOLA DRAWING TABLE BILD TABLA	INDEX NO. POS. N. INDICE	DISEGNO DRAWING DESSIN ZEICHNUNG DIBUJO	TAVOLA DRAWING TABLE BILD TABLA	INDEX NO. POS. N. INDICE	DISEGNO DRAWING DESSIN ZEICHNUNG DIBUJO	TAVOLA DRAWING TABLE BILD TABLA	INDEX NO. POS. N. INDICE	DISEGNO DRAWING DESSIN ZEICHNUNG DIBUJO	TAVOLA DRAWING TABLE BILD TABLA	INDEX NO. POS. N. INDICE
8000 66427	2	27	8000 67970	11	5	8000 69769	7	1	8000 71624	14	18	8000 73555	15	27
8000 66428	2	7	8000 67997	14	12	8000 69783	11	6	8000 71625	14	18	8000 73557	15	29
8000 66479	25	7	8000 67997	14	12	8000 69784	11	7	8000 71641	19	2	8000 73558	15	30
8000 66480	25	12	8000 68174	7	64	8000 69791	2	46	8000 71787	4	12	8000 73588	26	2
8000 66482	25	14	8000 68191	7	56	8000 69978	24	7	8000 71806	22	13	8000 73589	26	11
8000 66487	17	32	8000 68195	6	10	8000 69982	7	65	8000 71807	22	12	8000 73590	26	26
8000 66489	17	22	8000 68402	5	17	8000 69983	7	51	8000 72037	24	29	8000 73591	26	7
8000 66551	17	13	8000 68516	13	17	8000 69997	19	17	8000 72092	10	58	8000 73592	26	12
8000 66552	17	33	8000 68584	7	48	8000 70239	25	37	8000 72168	16	14	8000 73834	25	35
8000 66648	20	5	8000 68666	5	15	8000 70277	25	3	8000 72266	22	19	8000 73877	14	42
8000 66651	12	32	8000 68686	7	17	8000 70279	25	40	8000 72268	15	16	8000 74016	14	42
8000 66652	12	26	8000 68710	7	42	8000 70280	25	22	8000 72282	21	21	8000 74258	24	25
8000 66774	17	3	8000 68905	2	19	8000 70282	25	24	8000 72283	21	22	8000 74259	24	24
8000 66802	1	14	8000 68908	2	23	8000 70283	25	28	8000 72289	3	42	8000 74309	13	72
8000 66802	24	28	8000 69040	13	5	8000 70322	13	38	8000 72290	3	43	8000 74324	13	68
8000 66807	2	25	8000 69041	13	6	8000 70324	13	28	8000 72348	19	24	8000 74372	16	6
8000 66850	5	12	8000 69056	12	29	8000 70328	13	61	8000 72396	19	23	8000 74972	15	32
8000 66851	5	14	8000 69056	21	12	8000 70330	13	59	8000 72411	21	8	8000 74973	15	33
8000 66858	5	11	8000 69111	12	17	8000 70378	21	6	8000 72494	25	4	8000 74974	15	34
8000 67204	24	21	8000 69148	19	15	8000 70379	21	11	8000 72510	19	19	8000 74975	15	35
8000 67209	24	3	8000 69149	19	7	8000 70398	15	3	8000 72648	24	18	8000 74976	15	36
8000 67373	14	11	8000 69150	12	4	8000 70401	15	14	8000 72868	14	6	8000 74977	15	37
8000 67422	22A	1	8000 69156	2	29	8000 70402	15	15	8000 72869	14	50	8000 75040	28	12
8000 67434	10	54	8000 69163	23	23	8000 70404	15	3	8000 72873	14	6	8000 75043	22A	21
8000 67434	10A	54	8000 69164	23	24	8000 70637	1	10	8000 72874	14	28	8000 75155	17	1
8000 67440	20	19	8000 69165	23	8	8000 70696	18	5	8000 72875	14	27	8000 75160	14	44
8000 67444	10	52	8000 69282	14	25	8000 70698	17	31	8000 72884	14	3	8000 75166	14	9
8000 67444	10A	52	8000 69315	13	9	8000 70826	25	10	8000 72950	20A	16	8000 75166	14	40
8000 67449	5	18	8000 69345	13	8	8000 70991	2	42	8000 73140	12	3	8000 75310	17	2
8000 67457	10	10	8000 69428	24	4	8000 70993	4	16	8000 73141	13	11	8000 75413	27	13
8000 67457	10A	10	8000 69429	15	2	8000 70997	17	12	8000 73150	3	2	8000 75451	9	1
8000 67458	10	47	8000 69429	19	21	8000 71028	3	3	8000 73226	22A	16	8000 75477	24	23
8000 67458	10A	47	8000 69633	8A	23	8000 71186	21	23	8000 73341	12	9	8000 75584	2	17
8000 67496	21	9	8000 69715	8	1	8000 71230	8	14	8000 73394	16	2	8000 75672	11	15
8000 67700	20	20	8000 69715	8A	46	8000 71230	8A	30	8000 73504	15	18	8000 75673	11	13
8000 67720	12	25	8000 69722	8	57	8000 71232	17	20	8000 73509	15	17	8000 75700	6	11
8000 67724	12	27	8000 69722	8A	36	8000 71440	15	3	8000 73547	15	20	8000 75704	6	39
8000 67735	4	9	8000 69729	8	50	8000 71445	18	38	8000 73548	15	21	8000 75780	3	2
8000 67740	4	19	8000 69729	8A	60	8000 71445	22	22	8000 73549	15	22	8000 75800	12	18
8000 67744	2	6	8000 69736	8	28	8000 71557	21	7	8000 73550	15	23	8000 75801	12	18
8000 67824	4	11	8000 69737	8	54	8000 71578	25	47	8000 73552	15	24	8000 75842	17	11
8000 67825	4	10	8000 69738	8A	54	8000 71578	26	27	8000 73553	15	25	8000 75847	10A	43

DISEGNO DRAWING DESSIN ZEICHNUNG DIBUJO	TAVOLA DRAWING TABLE BILD TABLA	INDEX NO. POS. N. INDICE	DISEGNO DRAWING DESSIN ZEICHNUNG DIBUJO	TAVOLA DRAWING TABLE BILD TABLA	INDEX NO. POS. N. INDICE	DISEGNO DRAWING DESSIN ZEICHNUNG DIBUJO	TAVOLA DRAWING TABLE BILD TABLA	INDEX NO. POS. N. INDICE	DISEGNO DRAWING DESSIN ZEICHNUNG DIBUJO	TAVOLA DRAWING TABLE BILD TABLA	INDEX NO. POS. N. INDICE	DISEGNO DRAWING DESSIN ZEICHNUNG DIBUJO	TAVOLA DRAWING TABLE BILD TABLA	INDEX NO. POS. N. INDICE
8000 75868	16	1	8000 79069	22	3	8000 80206	13	35	8000 81193	13	65	1519632-01	1	12
8000 75941	19	6	8000 79070	22	10	8000 80257	20A	1	8000 81194	13	32	1610776-01	7	8
8000 75957	14	43	8000 79071	22	5	8000 80260	13	42	8000 81844	13	56	1610777-01	6	33
8000 76263	14	1	8000 79072	18	31	8000 80277	12	13	8000 81845	13	73	1610777-01	7	10
8000 76289	18	15	8000 79073	18	40	8000 80315	13	46	8000 82507	2	30	1611084-01	7	73
8000 76290	25	15	8000 79075	18	10	8000 80384	21	5	8000 84139	25	48	1611085-01	7	67
8000 76294	22A	7	8000 79096	22	4	8000 80535	4	16	80000 1199	20	6	1611216-01	7	27
8000 76295	22A	8	8000 79097	22	7	8000 80536	2	42	80000 1412	14	55	1611271-01	7	28
8000 76296	23	6	8000 79098	22	2	8000 80705	15	26	80000 1412	16	19	1611650-03	7	13
8000 76297	22A	8	8000 79099	22	8	8000 80711	13	1	80000 1688	23	3	1611677-02	7	35
8000 76298	22A	7	8000 79100	22	9	8000 80714	15	19	80000 2124	3	1	1611680-01	7	33
8000 76299	23	6	8000 79272	15	1	8000 80715	15	13	80000 4103	10	48	1611681-01	7	34
8000 76338	18	9	8000 79531	13	26	8000 80716	15	28	80000 4103	10A	48	1611683-02	7	23
8000 77373	13	34	8000 79532	13	25	8000 80717	15	31	80000 4104	10	49	1611684-01	7	24
8000 77391	9	3	8000 79534	13	30	8000 81156	13	74	80000 4104	10A	49	1611686-01	7	21
8000 77393	25	44	8000 79535	13	29	8000 81159	13	60	80000 6385	7	26	1611692-01	7	22
8000 77413	16	11	8000 79571	25	26	8000 81161	13	58	80000 8536	2	44	1611699-01	8	32
8000 77478	9	10	8000 79611	7	58	8000 81162	13	57	80000 8536	14	10	1611699-01	8A	12
8000 77627	5	24	8000 79618	5	19	8000 81163	13	55	1511249-01	14	19	1611701-01	8	40
8000 77699	22A	18	8000 79619	5	20	8000 81164	13	54	1511333-02	16	16	1611704-01	7	61
8000 77715	4	21	8000 79620	5	33	8000 81165	13	53	1513070-01	12	2	1611706-01	7	62
8000 77740	22	1	8000 79621	5	36	8000 81166	13	47	1513414-01	21	14	1611708-01	2	8
8000 77744	22A	10	8000 79623	13	20	8000 81167	13	41	1513713-01	4	4	1611708-01	7	39
8000 77745	18	28	8000 79624	13	10	8000 81168	13	40	1513714-01	8	47	1611715-01	8	44
8000 77748	22A	10	8000 79625	13	21	8000 81170	13	37	1513722-01	6	29	1611717-01	8	25
8000 77749	22A	5	8000 79754	17	16	8000 81171	13	36	1513726-02	6	3	1611717-01	8A	6
8000 77827	24	6	8000 79758	25	2	8000 81173	13	35	1513726-02	7	19	1611746-01	7	38
8000 77878	10A	1	8000 79759	24	19	8000 81174	13	33	1513743-01	21	15	1611816-04	6	14
8000 77879	10A	42	8000 79760	19	1	8000 81176	13	33	1514057-04	20A	10	1611837-01	8	27
8000 77884	22A	14	8000 79761	19	2	8000 81177	13	66	1514057-11	20	21	1612357-01	8	43
8000 78116	2	41	8000 79766	25	45	8000 81178	13	52	1514107-02	21	10	1612361-01	8	49
8000 78265	12	31	8000 79767	25	45	8000 81180	13	71	1514134-01	1	6	1612362-01	8	18
8000 78326	18	23	8000 79789	6	23	8000 81181	13	51	1515506-01	14	34	1612363-01	8	21
8000 78381	2	41	8000 79790	6	23	8000 81182	13	50	1515591-01	1	5	1612365-02	8	41
8000 78447	12	37	8000 79860	19	27	8000 81183	13	70	1515903-01	11	10	1612384-01	8	33
8000 78658	12	1	8000 79851	27	1	8000 81185	13	69	1516215-01	22A	12	1612384-01	8A	11
8000 78756	13	4	8000 79880	24	2	8000 81186	13	48	1517947-01	1	1	1612388-01	8	46
8000 78765	2	31	8000 80142	25	2	8000 81188	13	45	1517949-02	1	8	1612390-01	8	23
8000 79065	18	29	8000 80156	20A	14	8000 81189	13	67	1519653-01	1	2	1612415-01	8	48
8000 79065	22	17	8000 80157	20A	15	8000 81190	13	27	1519767-03	19	16	1612415-01	8A	9
8000 79066	18	30	8000 80204	15	9	8000 81191	13	64	1519805-01	1	4	1612480-01	8	20
8000 79066	22	23	8000 80205	13	35	8000 81192	13	31	1519847-01	1	13	1612481-01	8	19

DISEGNO DRAWING DESSIN ZEICHNUNG DIBUJO	TAVOLA DRAWING TABLE BILD TABLA	INDEX NO. POS. N. INDICE	DISEGNO DRAWING DESSIN ZEICHNUNG DIBUJO	TAVOLA DRAWING TABLE BILD TABLA	INDEX NO. POS. N. INDICE	DISEGNO DRAWING DESSIN ZEICHNUNG DIBUJO	TAVOLA DRAWING TABLE BILD TABLA	INDEX NO. POS. N. INDICE	DISEGNO DRAWING DESSIN ZEICHNUNG DIBUJO	TAVOLA DRAWING TABLE BILD TABLA	INDEX NO. POS. N. INDICE	DISEGNO DRAWING DESSIN ZEICHNUNG DIBUJO	TAVOLA DRAWING TABLE BILD TABLA	INDEX NO. POS. N. INDICE
1612699-01	8	39	1615358-01	2	3									
1612699-01	8A	13	1615359-02	2	18									
1612842-01	8	22	1615359-02	7	18									
1612842-01	8A	52	1615377-01	7	59									
1614589-01	6	32	1615378-01	7	60									
1614589-01	7	11	1615382-01	9	4									
1614590-01	7	7	1615383-01	9	10									
1614728-01	6	8	1615388-01	8	30									
1615014-02	5	27	1615388-01	8A	22									
1615023-01	2	14	1615390-01	10	44									
1615025-01	2	12	1615390-01	10A	44									
1615035-02	3	25	1615391-01	7	32									
1615036-01	3	17	1615393-01	3	15									
1615042-01	3	13	1615407-02	2	2									
1615043-01	3	8	1615408-01	3	23									
1615045-01	3	11	1616015-01	8A	47									
1615049-01	3	7	1616017-01	8A	27									
1615084-01	3	27	1616019-01	8A	51									
1615085-01	3	28	1616020-01	8A	25									
1615095-01	3	12	1616021-01	8A	10									
1615096-01	3	9	1616022-01	8A	2									
1615098-01	4	3	1616024-01	8A	3									
1615105-01	7	15	1616025-01	8A	8									
1615116-01	6	26	1616027-01	8A	48									
1615121-03	3	16	1616037-01	8A	26									
1615123-01	3	24	1616354-01	8A	19									
1615128-02	3	21	1616360-01	8A	49									
1615133-02	1	3	1616362-01	7	37									
1615141-03	3	19	1617955-01	2	37									
1615156-01	3	10	1619698-01	24	10									
1615230-01	2	16	1619854-01	3	40									
1615266-02	3	4												
1615275-01	9	14												
1615288-01	2	11												
1615294-01	2	10												
1615296-01	2	13												
1615303-01	2	17												
1615315-02	8	3												
1615315-02	8A	44												
1615332-01	2	4												
1615348-01	7	14												
1615351-01	2	15												