

INFORMAZIONI GENERALI

Il presente catalogo serve per richiedere con esattezza le parti di ricambio

Nelle ordinazioni indicare:

- 1) il numero di codice dei particolari seguito dalla descrizione;
- 2) il colore per i pezzi verniciati o comunque colorati;
- 3) il numero di matricola del motociclo, stampigliato sul canotto di sterzo.

Le indicazioni destra e sinistra si riferiscono ai lati del veicolo rispetto al senso di marcia.

GENERAL INFORMATION

The present spare parts list enables one to order exactly the right spare parts.

When ordering specify:

- 1) the part's code number followed by its description;
 - 2) indicate colour for painted or coloured parts;
 - 3) the motorcycle's serial number, stamped on the steering head.
- References to right and left apply to the vehicle in terms of its direction of movement.

INFORMATIONS GENERALES

Ca catalogue permet de commander correctement les pièces de rechange.

Les commandes doivent être passées en indiquant:

- 1) le numéro de code des pièces détachées suivi de leur description;
- 2) le couleur des pièces peintes ou colorés;
- 3) le matricule de la moto, estampillé sur la tige du guidon.

Droite et gauche sont les côtés du véhicule par rapport au sens de la marche.

ALLGEMEINE HINWEISE

Dieser Ersatzteilkatalog dient zur genauen Angabe der Teile bei Ersatzteilbestellungen.

Bei Ersatzbestellung ist folgendes anzugeben:

- 1) Die Bestellnummer der Ersatzteile mit der entsprechenden Beschreibung;
- 2) Farbe für lackierte und farbige Teile angeben;
- 3) Die Sseriennummer des Motorrads, die am Lenkrohr eingepreßt ist.

Die Angaben rechts und links beziehen sich auf das Fahrzeug in Fahrrichtung.

INFORMACIONES GENERALES

El presente catálogo sirve para pedir con exactitud las partes de recambio.

En los pedidos se debe indicar:

- 1) el número de código de la parte y a continuación la descripción;
- 2) el color para las piezas barnizadas o coloreadas;
- 3) el número de matrícula de la motocicleta, estampado en el tubo de dirección.

Las indicaciones derecha e izquierda se refieren a los lados del vehículo respecto del sentido de marcha.

NOTE - LIST - NOTES - NOTE - NOTAS:

- A** : In alternativa - In alternative - En alternative
Wahlweise - En alternativa
- DO** : In dotazione vers. omologata - To issue homologated version - En necessaire pour version homologuée
Ausrüstungsteileaus Ratifizierte Version - En dotaciòn versión homologada
- DR** : In dotazione - To issue - En necessaire
Ausrüstungsteile - En dotaciòn
- E** : Ad esaurimento - To fell out - A' finir - Erschöpfung
A agotamiento
- F** : Fornire assieme - Supply unitedly - Fournir ensemble
Wird zusammen geliefert - Equipar juntos
- M** : Modello SMR - SMR model - Modèle SMR - Modell SMR
Modélo SMR
- N** : Non fornito - Not supplied - Ne pas fournir
Keine Gelieferende - No equiparado
- R** : A richiesta - Upon request - Sur demande
Auf anfrage - Bajo pedido
- S** : Di serie - Supplied - De série - Standard - De serie
- U** : Solo per TE / U.S.A. - Only for TE / U.S.A. - Soulement pour TE / U.S.A. - Nur für TE / U.S.A. - Solo por TE / U.S.A.
- X** : Non per U.S.A. - Not for U.S.A. - Ne pas pour U.S.A.
Keine für U.S.A. - No por U.S.A.
- XBR** : Non per Brasile- Not for Brazil - Ne pas pour Brasile
Keine für Brasilien - No por Brasil
- W** : Modello TE - TE model - Modèle TE - Modell TE
Modélo TE
- Z** : n° denti, number of teeth, numéro dents, Zähne nummer
número dientes
- (&), (@) : Montati assieme- Assembled together

- A** : Austria, Austria, Autriche, Österreich, Austria
- AUS** : Australia, Australia, Australie, Australien, Australia
- B** : Belgio, Belgium, Belgique, Belgien, Bélgica
- BR** : Brasile, Brazil, Brasile, Brasilien, Brasil
- CDN** : Canada, Canada, Canada, Kanada, Canadá
- CH** : Svizzera, Switzerland, Suisse, Schweizer, Suiza
- D** : Germania, Germany, Allemagne, Deutschland, Alemania
- E** : Spagna, Spain, Espagne, Spanien, España
- F** : Francia, France, France, Frankreich, Francia
- GB** : Gran Bretagna, Great Britain, Grand Bretagne
Groos Britan, Gran Bretaña
- I** : Italia, Italy, Italie, Italien, Italia
- J** : Giappone, Japan, Japon, Japan, Japón
- SF** : Finlandia, Finald, Finlande, Finnland, Finlandia
- USA** : Stati Uniti d'America, United States of America
Etats Unis d'Amerique,
Vereinigste Staaten von Amerika, Estados Unidos

Il n° di matricola iniziale del modello **SMR 630** è **ZCGH610AA4V050001**

Il n° di matricola iniziale del modello **SMR 630 U.S.A.** è **ZCGSM633*4V000001**

The initial serial number for the **SMR 630** model is **ZCGH610AA4V050001**

The initial serial number for the **SMR 630 U.S.A.** model is **ZCGSM633*4V000001**

Le matricule initial du modèle **SMR 630** est **ZCGH610AA4V050001**

Le matricule initial du modèle **SMR 630 U.S.A.** est **ZCGSM633*4V000001**

Die Seriennummer des Modells **SMR 630** beginnt mit **ZCGH610AA4V050001**

Die Seriennummer des Modells **SMR 630 U.S.A.** beginnt mit **ZCGSM633*4V000001**

El n° de matrícula inicial de la motocicleta **SMR 630** es **ZCGH610AA4V050001**

El n° de matrícula inicial de la motocicleta **SMR 630 U.S.A.** es **ZCGSM633*4V000001**

Dati indicativi soggetti a modifiche senza impegno di preavviso.

All data are subject to modification without prior notice.

Données indicatif sujet au modifications sans obligation de préavis.

Anderungen Vorbehalten.

Datos indicativos sujetos a modificaciones sin compromiso de preaviso.

Tavola Drawing Table Bild Tabla	Denominazione	Description	Designation	Bezeichnung	Denominacion	Pagina Page Seite Paja
1	ATTREZZI DI ASSISTENZA, MANUALI E CATALOGHI	SERVICE TOOLS, MANUALS AND CATALOGS	OUTILS D'ASSISTANCE, MANUELS ET CATALOGUES	HILFAUSRUSTUNG, HANDBUCH UND KATALOG	HERRAMIENTAS DE ASISTENCIA, MANUALES Y CATALOGOS	11
2	TESTA, CILINDRO	CYLINDER HEAD, CYLINDER	CULASSE, CYLINDRE	ZYLINDERKOPF, ZYLINDER	CULATA, CILINDRO	13
3	DISTRIBUZIONE	VALVE TIMING	DISTRIBUTION	VENTILSTEUERUNG	DISTRIBUCION	17
4	PISTONE, MANOVELLISMO	PISTON, CRANKSHAFT	PISTON, VILEBREQUIN	KOLBEN, KURBELWELLE	PISTON, PALANCAS	21
5	RAFFREDDAMENTO	COOLING SYSTEM	REFROIDISSEMENT	WASSERKÜHLUNG	ENFRIAMIENTO	23
6	SEMICARTER DESTRO	R.H. HALF CRANKCASE	CARTER D.	GEHAUSEDECKEL R.	BANCADA DER.	27
7	SEMICARTER SINISTRO, AVVIAMENTO	L.H. HALF CRANKCASE, STARTING	CARTER G., DEMARRAGE	GEHAUSEDECKEL L., ANLASSER	BANCADA IZQ., ARRANQUE	31
8	CAMBIO, COMANDO CAMBIO, FRIZIONE	TRANSMISSION, SHIFTER, CLUTCH	BOITE DE VITESSE, COMMANDE DE VITESSE, EMBRAYAGE	WECHSELGETRIEBE, GANGSCHALTUNG ,KUPPLUNG	CAMBIO, MANDO CAMBIO , EMBRAGUE	37
9	ACCENSIONE	IGNITION	ALLUMAGE	ZÜNDUNG	ENCENDIDO	41
10	CARBURATORE KEIHIN	CARBURETOR KEIHIN	CARBURATEUR KEIHIN	VERGASER KEIHIN	CARBURADOR KEIHIN	43
11	FILTRO ARIA	AIR FILTER	FILTRE AIRE	AIRFILTER	FILTRO DE AIRE	45
12	TELAIO, PEDANE	FRAME, FOOT RESTS	CADRE, REPOSE PIEDS	RAHMEN, FUSSRASTE	BASTIDOR, REPOSAPIES	47
13	SOSPENSIONE ANTERIORE	FRONT FORK ASSEMBLY	SUSPENSION AVANT	VORDERTELESKOPGABEL	SUSPENSION DELANTERA	51
14	FORCELLONE	SWING ARM	FOURCHE	HINTERGABEL	HORQUILLA TRASERA	57
15	AMMORTIZZATORE POSTERIORE	REAR SHOCK ABSORBER	AMMORTISSEUR ARRIÈRE	HINTERSTOSSDAMPFER	AMORTIGUADOR TRASERO	59
16	LEVERAGGI SOSPENSIONE POST.	REAR SUSPENSION LINKAGE	LEVIER SUSPENSION ARRIERE	HEBELWERK HINTERHAUFHANGUNG	PALANCA SUSPENSION TRASERA	61
17	MANUBRIO E COMANDI	HANDLEBAR AND CONTROLS	GUIDON ET COMMANDES	LENKER UND STEUERORGANE	MANILLAR Y MANDOS	63
18	FRENO IDRAULICO POSTERIORE	REAR HYDRAULIC BRAKE	FREIN HYDRAULIQUE ARRIERE	HINTERBREMSE	FRENO HIDRAULICO TRASERO	65
19	PANNELLI LAT., PARAFANGHI, SELLA	SIDE PANELS, FENDERS, SEAT	PANNEAU, GARDE-BOUES , SIEGE	STREIFEN, KOTFLUGEL, SATTEL	PANELES, GUARDABARROS, SILLIN	67
20	SERBATOIO CARBURANTE, CONVOGIATORI	GAS TANK, PANELS	RESERVOIR CARBURANT, FLANCS	KRAFTSTOFFBEHALTER, FLANKE	DEPOSITO GASOLINA, LATERALES	69
21	SCARICO	EXHAUST SYSTEM	TUYAU D'ECHAPPEMENT	AUSPUFFROHR	TUBO DE ESCAPE	71
22	FRENO IDRAULICO ANTERIORE	FRONT HYDRAULIC BRAKE	FREIN HYDRAULIQUE AVANT	VORTERBREMSE	FRENO HIDRAULICO DELANTERO	73
23	RUOTA ANTERIORE	FRONT WHEEL	ROUE AVANT	VORTERRAD	RUEDA DELANTERA	75
24	RUOTA POSTERIORE	REAR WHELL	ROUE ARRIERE	HINTERRAD	RUEDA TRASERA	77
25	DECALCOMANIE	TRANSFER	DECALCOMANIE	ABZIEHBILD	CALCOMANIA	79
-	INDICE NUMERICO PROGRESSIVO	NUMERICAL INDEX	INDEX NUMERIQUE	NUMMERNVERZEICHNIS	ÍNDICE NUMÉRICO PROGRESIVO	80

Tavola - Drawing - Table - Bild - Tabla

1

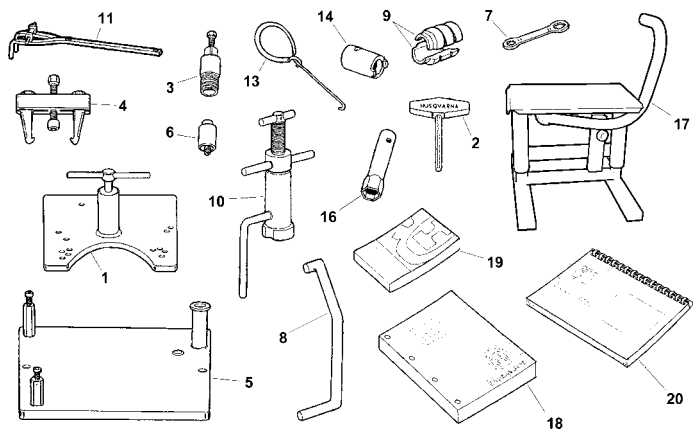

Pagina - Page - Page - Seite - Paja

8

Tavola - Drawing - Table - Bild - Tabla

2

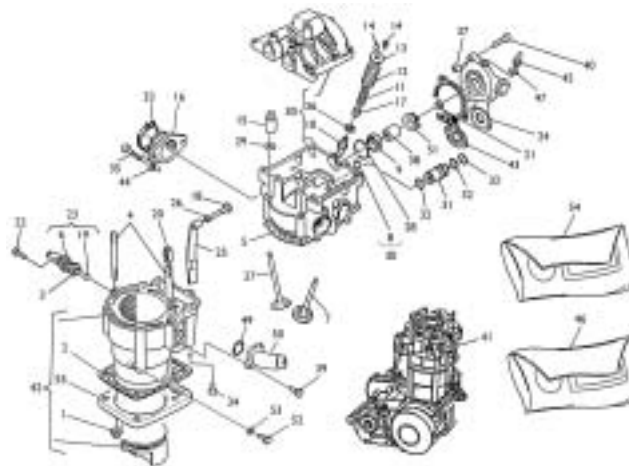

Pagina - Page - Page - Seite - Paja

10

Tavola - Drawing - Table - Bild - Tabla

3

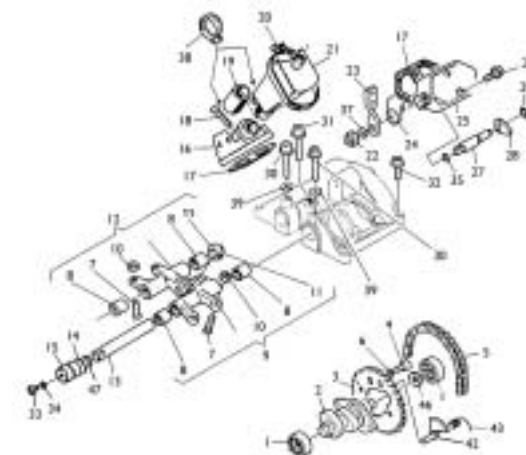

Pagina - Page - Page - Seite - Paja

14

Tavola - Drawing - Table - Bild - Tabla

4

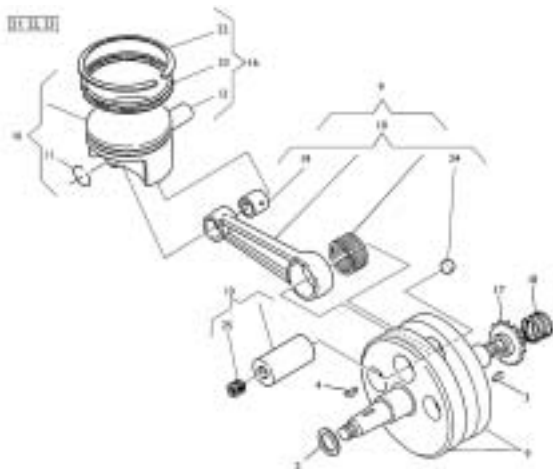

Pagina - Page - Page - Seite - Paja

18

Tavola - Drawing - Table - Bild - Tabla

5

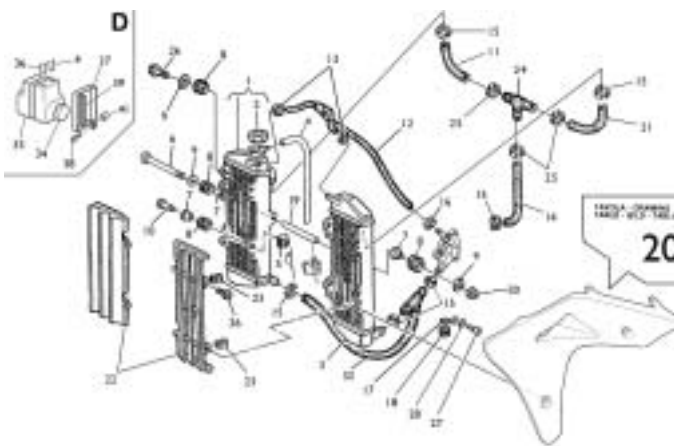

Pagina - Page - Page - Seite - Paja

20

Tavola - Drawing - Table - Bild - Tabla

6

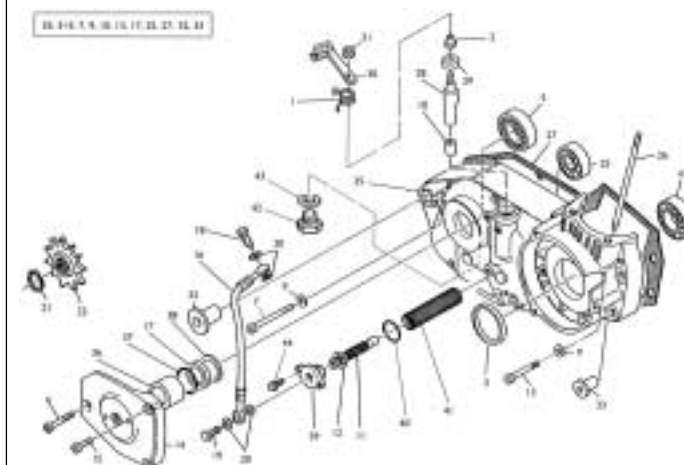

Pagina - Page - Page - Seite - Paja

24

Tavola - Drawing - Table - Bild - Tabla

7

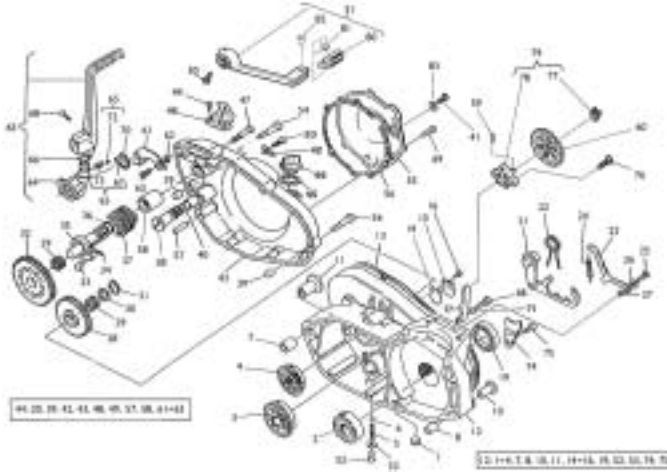

Pagina - Page - Page - Seite - Paja

28

Tavola - Drawing - Table - Bild - Tabla

8

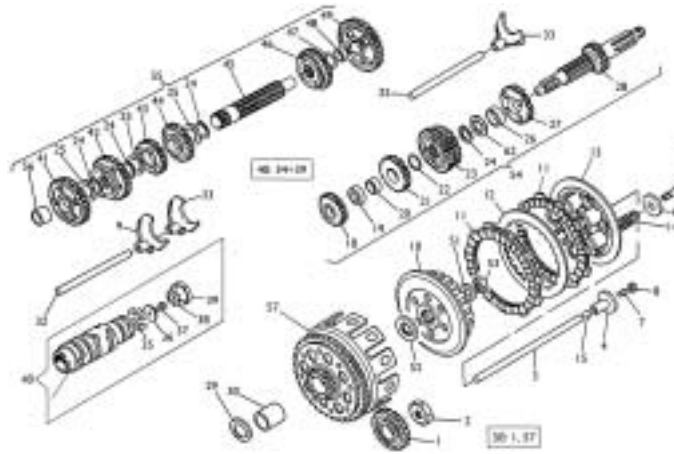

Pagina - Page - Page - Seite - Paja

34

Tavola - Drawing - Table - Bild - Tabla

9

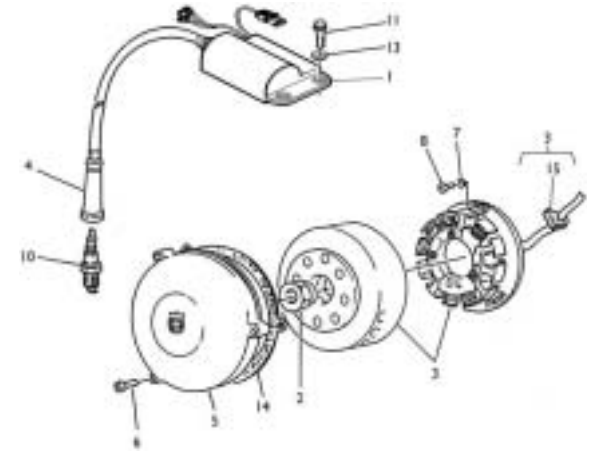

Pagina - Page - Page - Seite - Paja

38

Tavola - Drawing - Table - Bild - Tabla

10

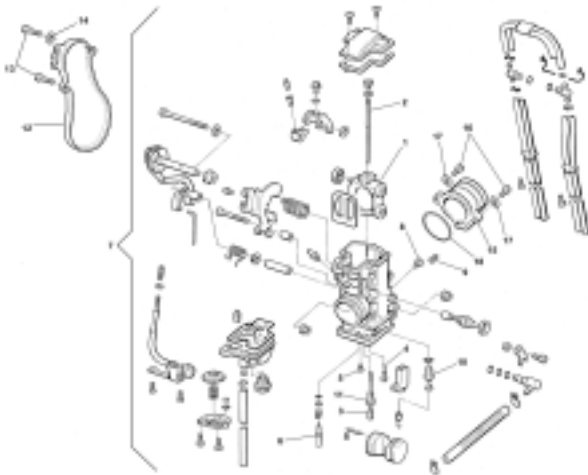

Pagina - Page - Page - Seite - Paja

40

Tavola - Drawing - Table - Bild - Tabla

11

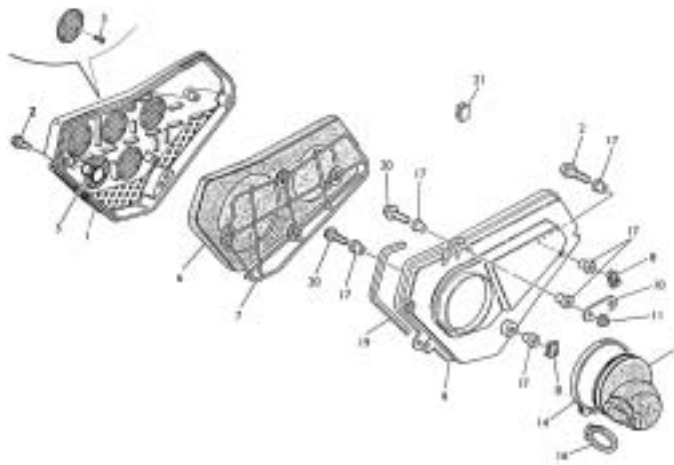

Pagina - Page - Page - Seite - Paja

42

Tavola - Drawing - Table - Bild - Tabla

12

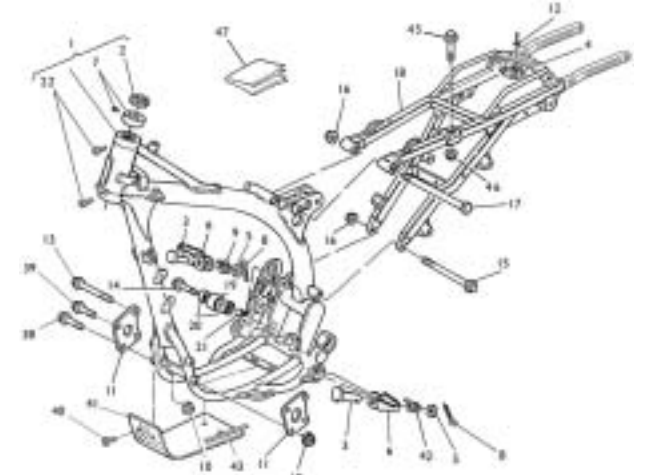

Pagina - Page - Page - Seite - Paja

44

Tavola - Drawing - Table - Bild - Tabla

13

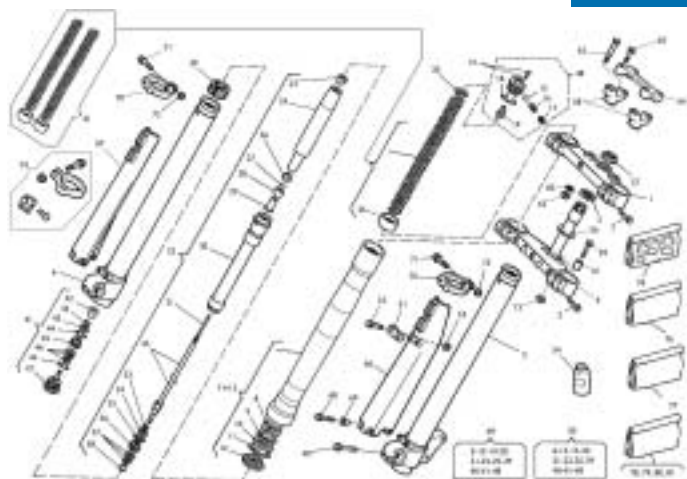

Pagina - Page - Page - Seite - Paja

48

Tavola - Drawing - Table - Bild - Tabla

14

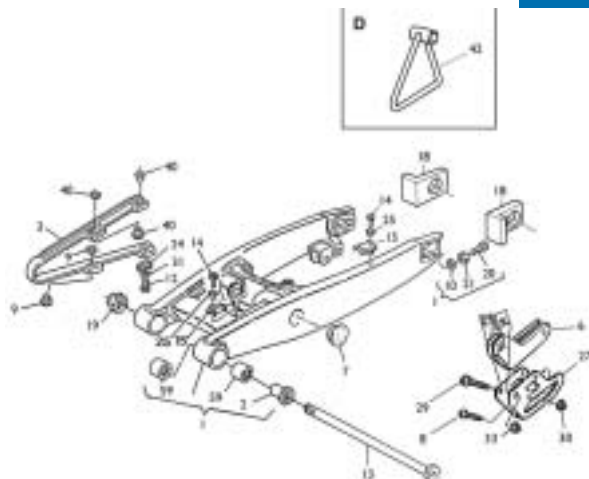

Pagina - Page - Page - Seite - Paja

54

Tavola - Drawing - Table - Bild - Tabla

15

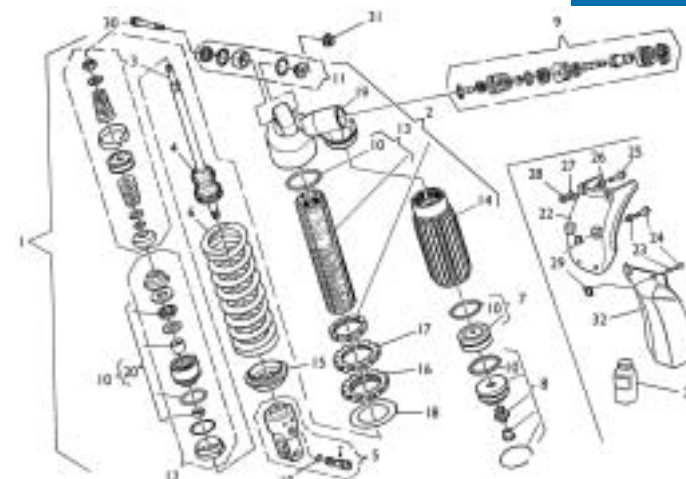

Pagina - Page - Page - Seite - Paja

56

Tavola - Drawing - Table - Bild - Tabla

16

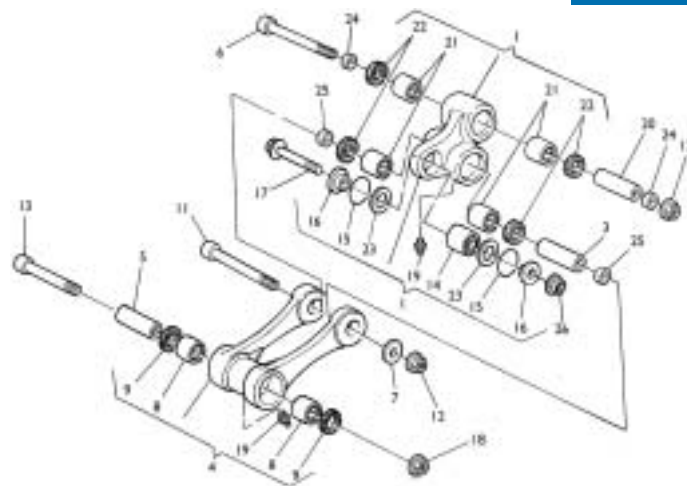

Pagina - Page - Page - Seite - Paja

58

Tavola - Drawing - Table - Bild - Tabla

17

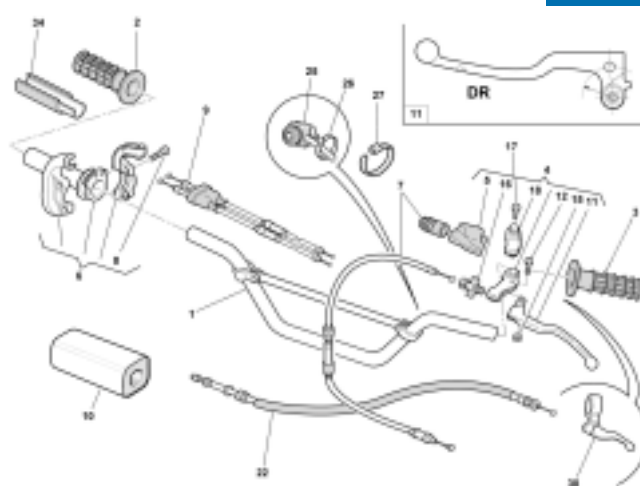

Pagina - Page - Page - Seite - Paja

60

Tavola - Drawing - Table - Bild - Tabla

18

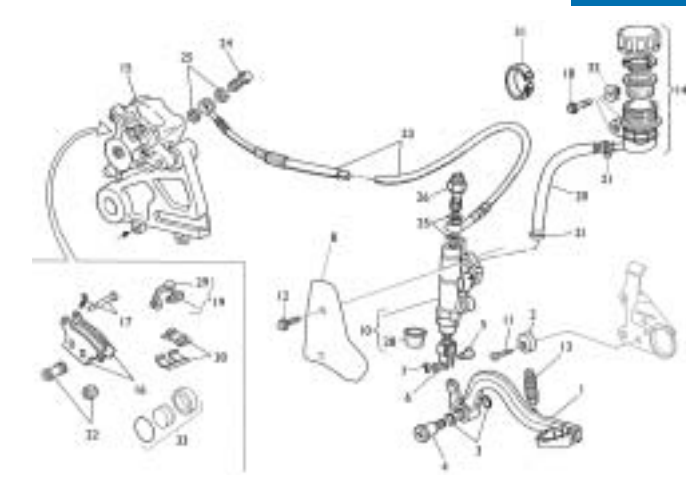

Pagina - Page - Page - Seite - Paja

62

Tavola - Drawing - Table - Bild - Tabla

19

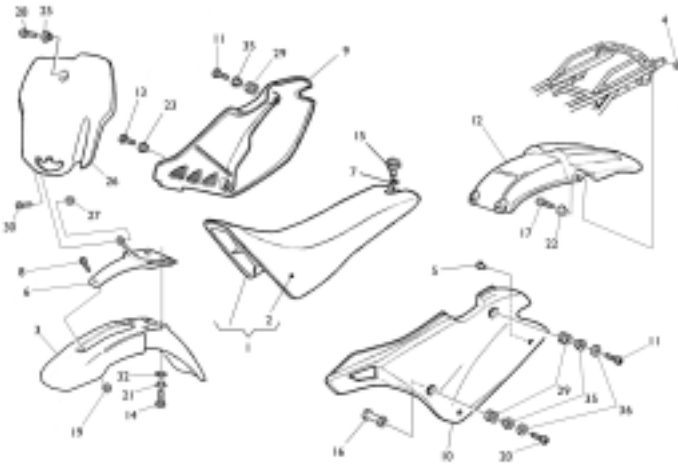

Pagina - Page - Page - Seite - Paja

64

Tavola - Drawing - Table - Bild - Tabla

20

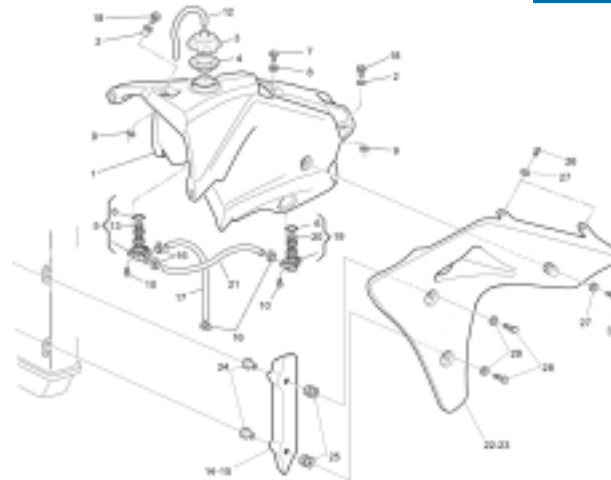

Pagina - Page - Page - Seite - Paja

66

Tavola - Drawing - Table - Bild - Tabla

21

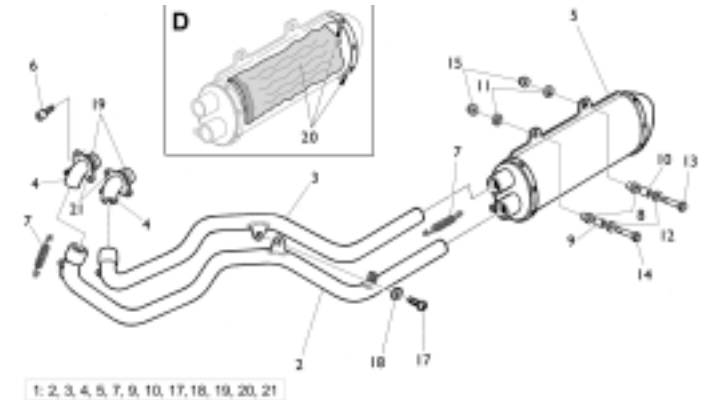

Pagina - Page - Page - Seite - Paja

68

Tavola - Drawing - Table - Bild - Tabla

22

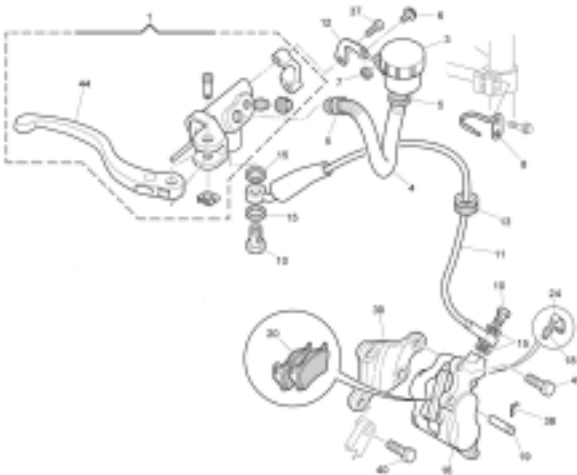

Pagina - Page - Page - Seite - Paja

70

Tavola - Drawing - Table - Bild - Tabla

23

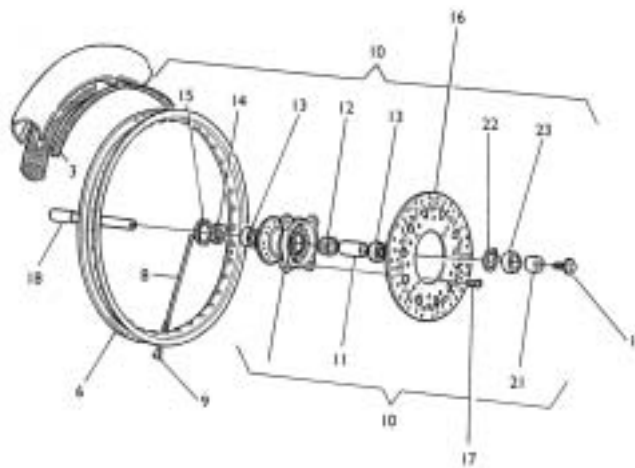

Pagina - Page - Page - Seite - Paja

72

Tavola - Drawing - Table - Bild - Tabla

24

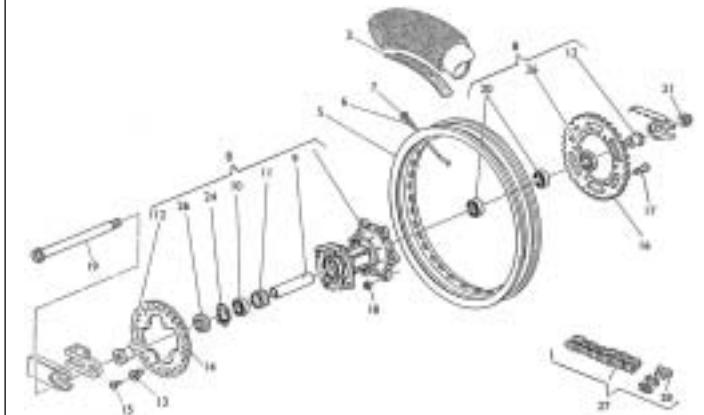

Pagina - Page - Page - Seite - Paja

74

Tavola - Drawing - Table - Bild - Tabla

25

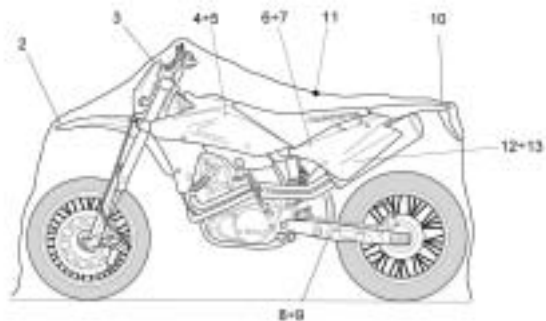

Pagina - Page - Page - Seite - Paja

76

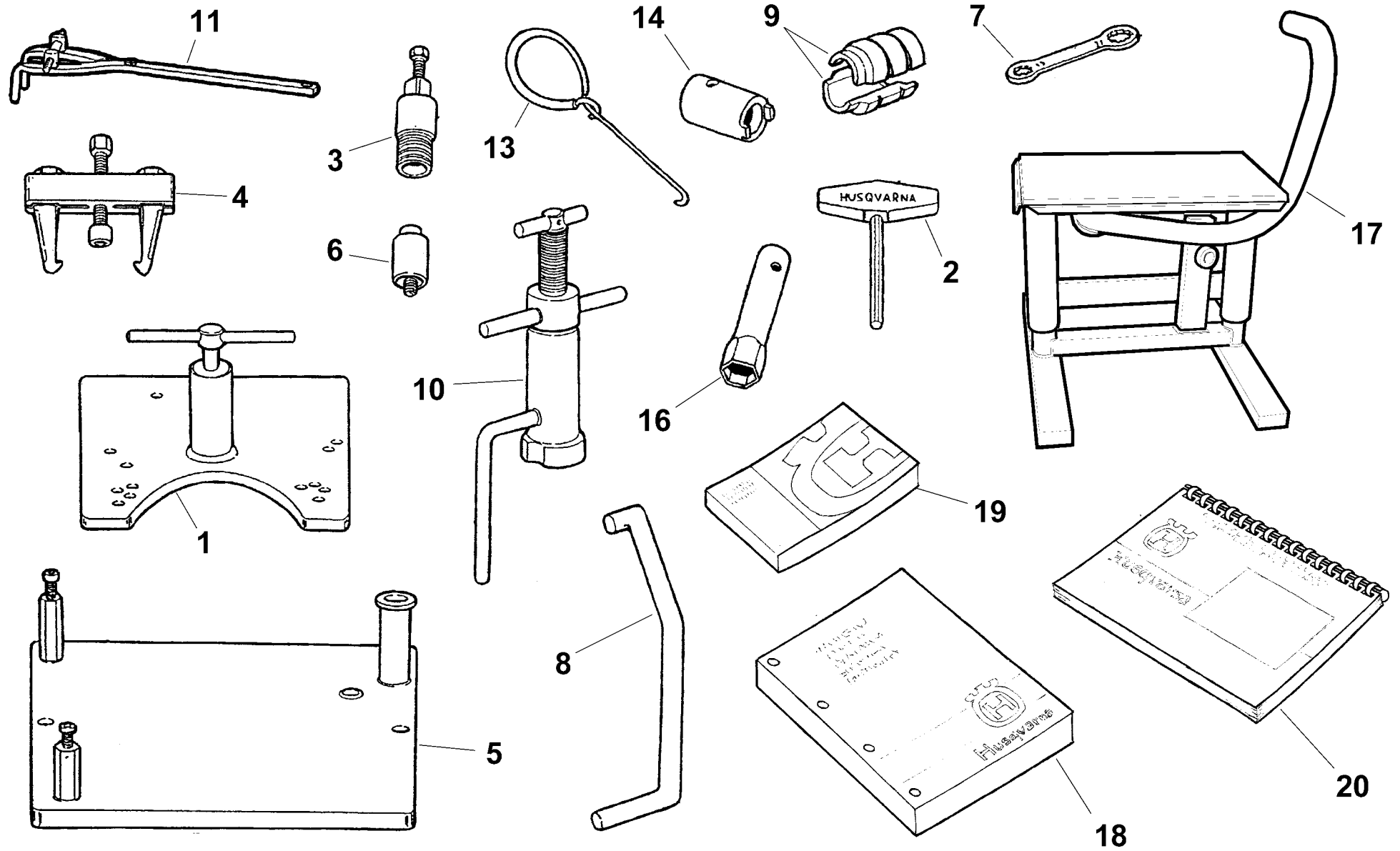



**SMR 630 Seel
replica**

TAVOLA
DRAWING
TABLE
BILD
TABLA

1

**ATTREZZI DI ASSISTENZA, MANUALI E CATALOGHI - SERVICE TOOLS, MANUALS AND CATALOGS
OUTILS D'ASSISTANCE, MANUELS ET CATALOGUES - HILFAUSRÜSTUNG, HANDBUCH UND KATALOG -
HERRAMIENTAS DE ASISTENCIA, MANUALES Y CATALOGOS**

Note Notes Notas	Pos. No. Index Pos.	N. Cod. Code No. Nr. Code Code Nr N. Cod.	Q.tà Q.ty Q.te M.ge C.ad	DENOMINAZIONE	NAME	DESIGNATION	BESHREIBUNG	DENOMINACION	Validità Validity Validité Gültig Validez
	1	1517 94701	1	Estrattore basamento	Crankcase puller	Extracteur carter	Kurbelgehäuse-Auszieher	Extractor cárter	
	2	1519 65301	1	Chiave per esagono incassato	Allen wrench	Clé hexagonale	Sechskanteinsteckschlüssel	Llave de Allen	
	3	1615 13302	1	Estrattore volano	Flywheel extractor	Extracteur pour volant	Auszieher für Schwungrad	Extractor volante	
	4	1519 80501	1	Estr. ingranaggio lato frizione	Clutch gear puller	Extract. engr. côté embrayage	Auszieher Kupplungszahnrad	Extr. engran. lado fricción	
	5	1515 59101	1	Supporto per montaggio	Support for assy	Support pour montage	Halterung für Montage	Soporte por el montaje	
	6	1514 13401	1	Estrattore braccio oscillante	Swing arm puller	Extract. bras oscillant	Schwingarm-Abzieher	Extractor brazo oscilante	
D	7	8000 66802	1	Chiave poligonale	Poligonal wrench	Cléf polygonale	Sechskantschlüssel	Llave poligonal	
	8	1517 94902	1	Attrezzo per volano	Tool for flywheel	Outil pour volant	Vorrichtung für Schwungrad	Herramienta para volante	
	9	8000 91288	1	Introduttore MIM	Jaw	Machoire	Zusatzbacke	Tenaza	
	10	8000 70637	1	Attrezzo mont. albero motore nel carter sinistro	Installing tool. crankshaft left	Outil pour montage vilebrequin dans le demicarter G.	Werkzeug für Montage der Kurbelwelle im L. Gehäuse	Herramienta mont. eje motor en el carter izq.	
	11	8000 79015	1	Chiave di fermo mozzo frizione	Clutch hub retaining wrench	Cléf d'arret moyeau	Halterungsschlüssel der Kupplungsnabe	Llave bloquear cubo fricción	
	13	1519 84701	1	Gancio per molle	Spring hook	Crochet pour ressort	Federhaken	Gancho para resorte	
	14	8000 91289	1	Attrezzo blocca cartuccia	Pumping retainer	Arrêt pompage	Klammer pumpen	Broche bombeadora	
D	16	1619 69801	1	Chiave candela	Spark plug wrench	Cléf bougie	Zündkerzeschlüssel	Llave bujia	
D	17	8000 98464	1	Cavalletto	Support	Support	Halterung	Soporte	
D	18	8000 A3632	1	Manuale di officina	Workshop manual	Mauel d'atelier	Werkstatthandbuch	Manual de oficina	
D	19	8000 A3631	1	Libretto uso e manutenzione	Owner's manual	Emploi d'entretien	Betriebsanleitung	Manual uso y mantenimiento	
D	20	8000 A3633	1	Catalogo "Parti di Ricambio"	SPARE PARTS catalog	Catalogue "PIECES DE RECHANGE"	ERSATZTEILKATALOG	Catalogo "PIEZAS DE REPUESTO"	

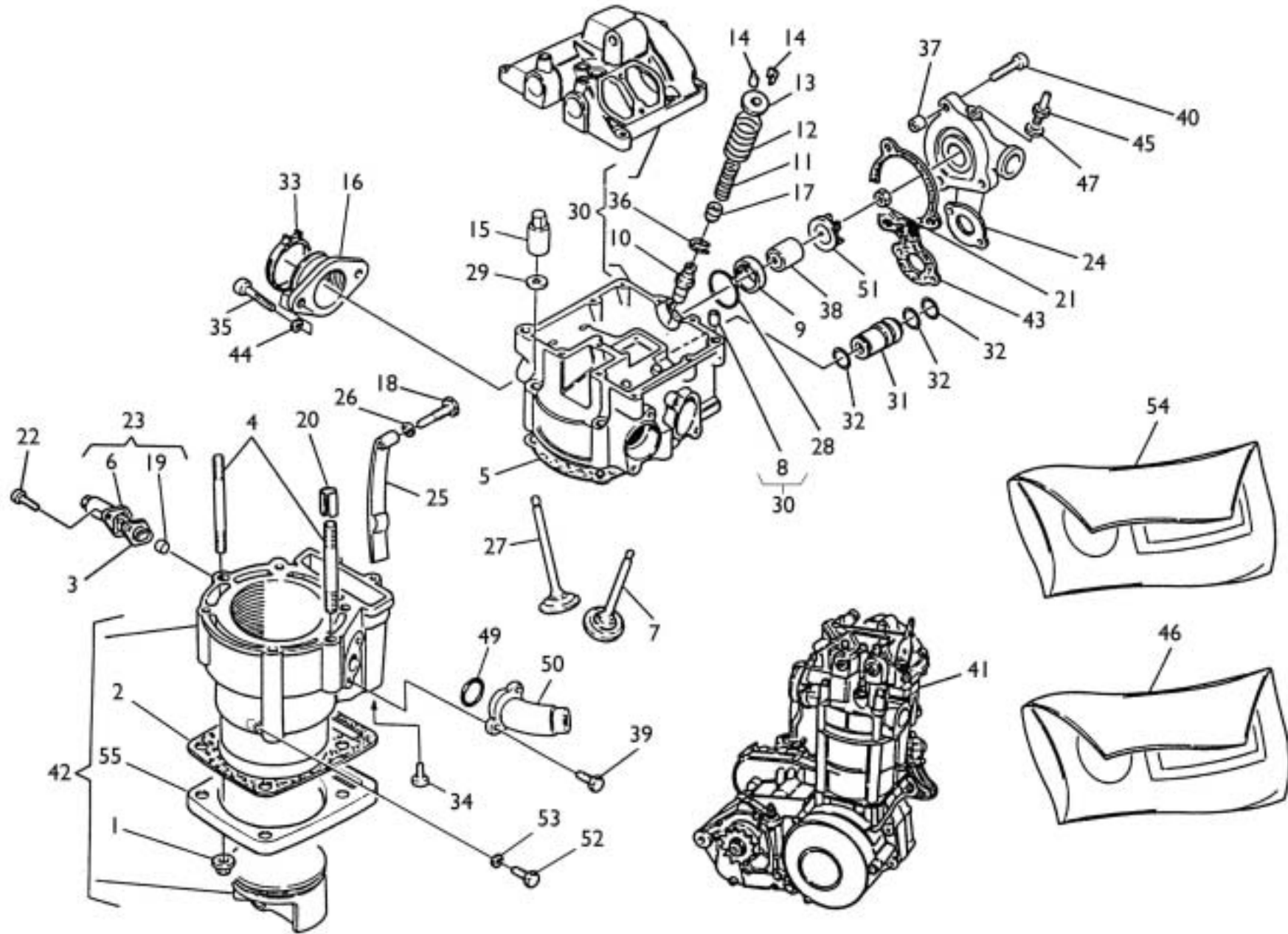



**SMR 630 Seel
replica**

TAVOLA
DRAWING
TABLE
BILD
TABLA

2

**TESTA, CILINDRO - CYLINDER HEAD, CYLINDER
CULASSE, CYLINDRE - ZYLINDERKOPF, ZYLINDER
CULATA, CILINDRO**

Note Notes Notas	Pos. No. Index Pos.	N. Cod. Code No. Nr. Code Code Nr N. Cod.	Q.tà Q.ty Q.te M.ge C.ad	DENOMINAZIONE	NAME	DESIGNATION	BESHREIBUNG	DENOMINACION	Validità Validity Validité Gültig Validez
	1	8000 92907	2	Dado	Nut	Ecrou	Mutter	Tuerca	
	2	1615 40702	1	Guarnizione	Gasket	Garnitue	Dichtung	Junta	
	3	1615 35801	1	Guarnizione	Gasket	Garnitue	Dichtung	Junta	
	4	8000 92822	2	Prigioniero	Stud bolt	Prisonnier	Stiftschraube	Prisionero	
	5	8000 64726	1	Guarnizione	Gasket	Garnitue	Dichtung	Junta	
	6	8000 67744	1	Tenditore	Tensioner	Tendeur	Zylinderspanner	Tensor	
	7	8000 66428	2	Valvola scarico	Exhaust valve	Soupape d'échappement	Auslass-Ventil	Válvula de escape	
	8	1611 70801	2	Bussola	Bushing	Douille	Buchse	Manguito	
	9	8000 63817	1	Bussola	Bushing	Douille	Buchse	Manguito	
	10	1615 29401	4	Guidavalvola	Valve guide	Guide-soupape	Ventilführung	Guía-válvula	
	11	1615 28801	4	Molla interna	Spring	Ressort	Feder	Resorte	
	12	1615 02501	4	Molla esterna	Spring	Ressort	Feder	Resorte	
	13	1615 29601	4	Scodellino	Cup	Cuvette	Teller	Cubeta	
	14	1615 02301	8	Semicono	Half cone	Demi-cône	Halb Kegel	Semi-cono	
	15	8000 92837	4	Dado	Nut	Ecrou	Mutter	Tuerca	
	16	8000 98205	1	Raccordo	Union	Raccord	Anschluss	Empalme	
	17	1615 30301	4	Anello di tenuta	Seal ring	Bague d'étanchéité	Dichtungsring	Anillo de retención	
A	17	8000 75584	4	Anello di tenuta	Seal ring	Bague d'étanchéité	Dichtungsring	Anillo de retención	
	18	8000 92838	1	Vite	Screw	Vis	Schraube	Tornillo	
	19	8000 68905	1	Distanziale	Spacer	Entretoise	Distanzstück	Separador	
	20	8000 47708	2	Spina elastica	Pin	Goupille	Stift	Clavija	
	21	8000 42278	1	Dado	Nut	Ecrou	Mutter	Tuerca	
	22	8B00 96721	2	Vite	Screw	Vis	Schraube	Tornillo	
	23	8000 68908	1	Tenditore completo	Complete tensioner	Tendeur complet	Zylinderspanner	Tensor completo	
	24	80C0 75766	1	Corpo pompa	Pump body	Corps pompe	Pumpenkörper	Corpo bomba	
	25	8000 66807	1	Pattino catena	Chain slider	Glissière	Gleitbahn	Plato cadena	
	26	8000 45194	1	Rosetta piana	Washer	Rondelle	Scheibe	Arandela	
	27	8000 66427	2	Valvola aspirazione	Inlet valve	Soupape admission	Einlass-Ventil	Válvula aspiración	
	28	8000 59942	1	Anello OR	O-Ring	Bague OR	O-Ring	Anillo OR	
	29	8000 69156	4	Rosetta piana	Washer	Rondelle	Scheibe	Arandela	
	30	8B00 78437	1	Coperchio e testa	Cover and head	Couvercle et culasse	Dekel und Zylinderkopf	Tapa e culata	
	31	8A00 78765	1	Tubetto	Pipe	Tuyau	Rohr	Tubo	
	32	8000 18422	3	Anello OR	O-Ring	Bague OR	O-Ring	Anillo OR	

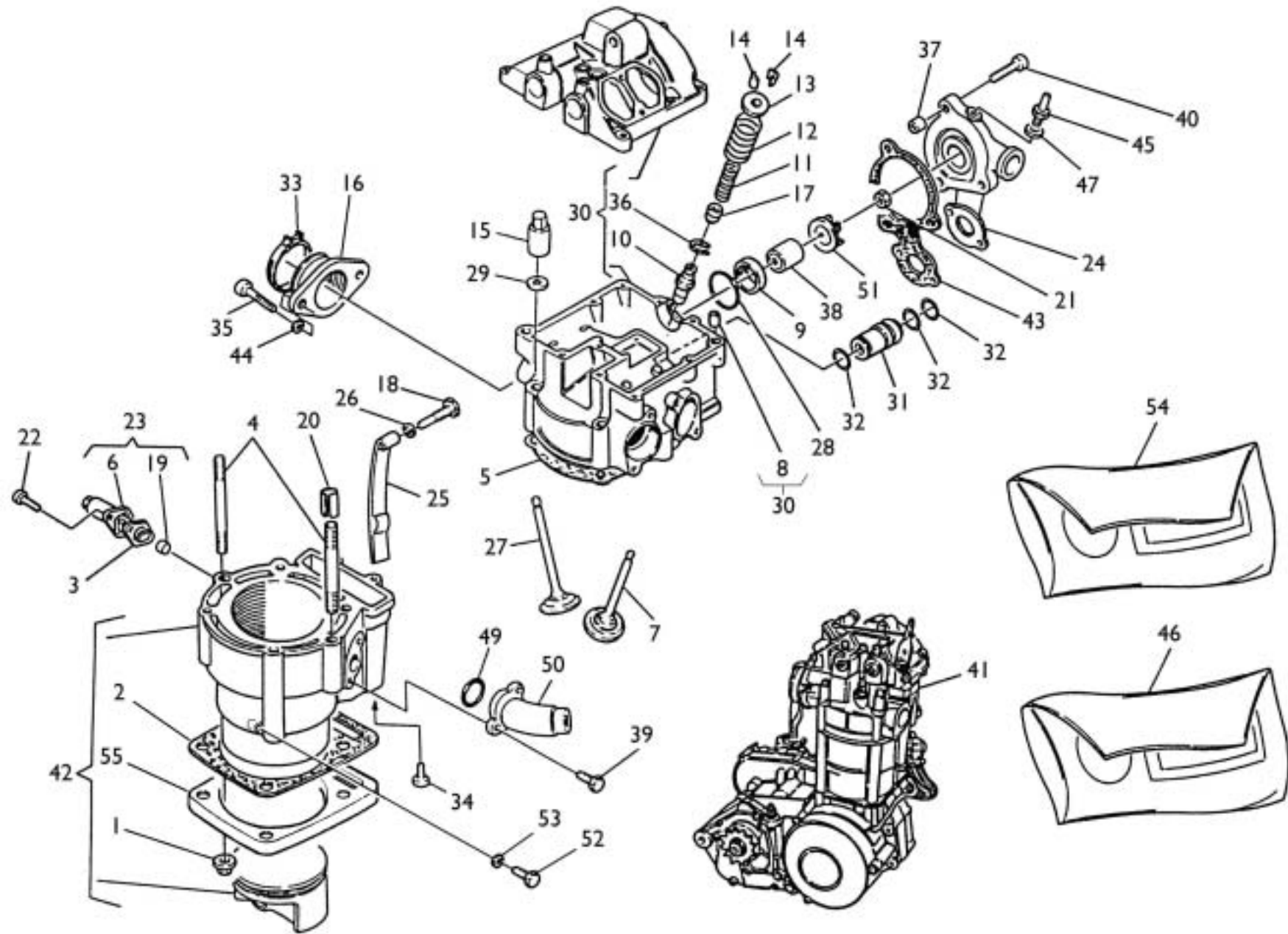



**SMR 630 Seel
replica**

TAVOLA
DRAWING
TABLE
BILD
TABLA

2

**TESTA, CILINDRO - CYLINDER HEAD, CYLINDER
CULASSE, CYLINDRE - ZYLINDERKOPF, ZYLINDER
CULATA, CILINDRO**

Note Notes Mark Notas	Pos. No. N. Index Pos.	N. Cod. Code No. Nr. Code Code Nr N. Cod.	Q.tà Q.ty Q.te M.ge C.ad	DENOMINAZIONE	NAME	DESIGNATION	BESHREIBUNG	DENOMINACION	Validità Validity Validité Gültig Validez
	33	8000 98290	1	Fascetta	Clamp	Collier	Schelle	Banda	
	34	8E00 96718	2	Vite (M6x30 mm)	Screw (M6x30 mm)	Vis (M6x30 mm)	Schraube (M6x30 mm)	Tornillo (M6x30 mm)	
	35	8D00 96719	2	Vite	Screw	Vis	Schraube	Tornillo	
	36	8000 59940	4	Anello di arresto	Snap ring	Bague d'arrêt	Haltering	Anillo elástico de retención	
	37	1617 95501	2	Bussola	Bushing	Douille	Buchse	Manguito	
	38	8000 53339	1	Anello di tenuta	Seal ring	Bague d'étanchéité	Dichtungsring	Anillo de retención	
	39	8B00 96721	2	Vite	Screw	Vis	Schraube	Tornillo	
	40	8E00 96721	5	Vite	Screw	Vis	Schraube	Tornillo	
	41	8000 A3622	1	Assieme motore	Engine assy	Moteur complet	Motor kpl.	Motor compl.	
	42	8000 98176	1	Cilindro completo (gilardoni)	Cylinder assy (gilardoni)	Cylindre compl. (gilardoni)	Zylinder kpl. (gilardoni)	Cilindro compl. (gilardoni)	
A	42	8000 98178	1	Cilindro completo (tecnol)	Cylinder assy (tecnol)	Cylindre compl. (tecnol)	Zylinder kpl. (tecnol)	Cilindro compl. (tecnol)	
	43	8A00 63644	1	Guarnizione	Gasket	Garnitue	Dichtung	Junta	
	44	8000 08536	2	Rosetta piana	Washer	Rondelle	Scheibe	Arandela	
	45	8000 66395	1	Raccordo	Union	Raccord	Anschluss	Empalme	
D	46	8000 96880	1	Gruppo guarnizioni motore	Gasket set	Groupe garnitures	Dichtungssatz	Grupo juntas	
	47	8A00 15960	1	Rosetta	Washer	Rondelle	Scheibe	Arandela	
	49	8000 19789	1	Anello OR	O-Ring	Bague OR	O-Ring	Anillo OR	
	50	80A0 66222	1	Raccordo	Union	Raccord	Anschluss	Empalme	
	51	8A00 60415	1	Girante	Rotor	Couronne	Laufrad	Rotor	
	52	8A00 96721	1	Vite M6x10mm	Screw	Vis	Schraube	Tornillo	
	53	8A00 15960	1	Rosetta	Washer	Rondelle	Scheibe	Arandela	
D	54	8000 96881	1	Gruppo anelli di tenuta motore	Engine seal ring set	Groupe bague moteur	Dichtungsringgruppe Motor	Grupo anillos	
	55	8000 85354	1	Spessore base cilindro	Cylinder base spacer	Entretoise base cylindre	Zylinderbase Distanzstück	Separadør por base cilindro	

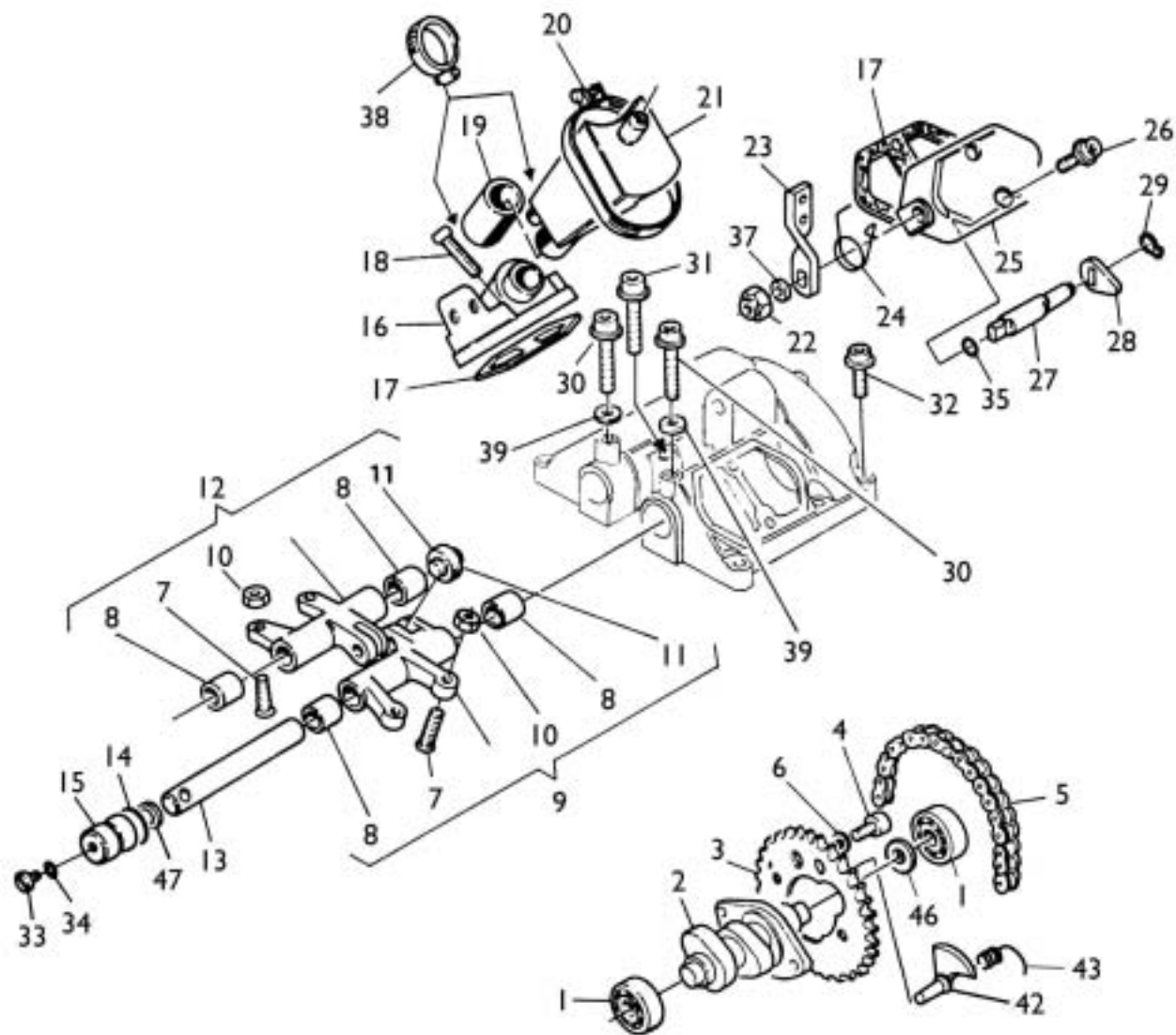



SMR 630 Seel replica

TAVOLA
DRAWING
TABLE
BILD
TABLA

3

DISTRIBUZIONE - VALVE TIMING DISTRIBUTION - VENTILSTEUERUNG DISTRIBUCION

Note Notes Notas	Pos. No. N. Index Pos.	N. Cod. Code No. Nr. Code Code Nr N. Cod.	Q.tà Q.ty Q.te M.ge C.ad	DENOMINAZIONE	NAME	DESIGNATION	BESHREIBUNG	DENOMINACION	Validità Validity Validité Gültig Validez
	1	8000 02124	2	Cuscinetto (ø12xø32x10 mm)	Bearing (ø12xø32x10 mm)	Roulement (ø12xø32x10 mm)	Lager (ø12xø32x10 mm)	Cojinete (ø12xø32x10 mm)	
	2	8000 75780	1	Albero a camme	Camshaft	Arbre distribution	Nockenwelle	Eje distribución	
	3	8000 82337	1	Ingranaggio condotto	Driven gear	Engrange conduit	Zahnrad	Engranaje conducto	
	4	1615 26602	2	Vite	Screw	Vis	Schraube	Tornillo	
	5	8000 92918	1	Catena distribuzione	Chain	Chaîne	Kette	Cadena	
	6	62N1 15658	2	Rosetta elastica	Spring washer	Rondelle élastique	Federscheibe	Arandela elástica	
	7	1615 04901	4	Vite di registro	Adjusting screw	Vis de réglage	Verstellungsschraube	Tornillo de regulación	
	8	1615 04301	4	Bussola	Bushing	Douille	Buchse	Manguito	
	9	1615 09601	1	Bilancere di scarico completo	Exhaust rocker-arm assy	Culbuteur échappem. compl.	Kipphebel Auspuffrohr kpl.	Balancín de escape compl.	
	10	1615 15601	4	Dado	Nut	Ecrou	Mutter	Tuerca	
	11	1615 04501	2	Cuscinetto a rullini	Needle bearing	Roulement à aiguilles	Nadelkäfig	Cojinete de rodillos	
	12	1615 09501	1	Bilancere di aspirazione compl.	Inlet rocker-arm assy	Culbuteur d'aspiration compl.	Kipphebel Ansaugen kpl.	Balancín de aspiración compl.	
	13	1615 04201	2	Perno	Pin	Pivot	Bolzen	Perno	
	14	8000 59939	2	Anello OR	O-Ring	Bague OR	O-Ring	Anillo OR	
	15	1615 39301	2	Tappo	Plug	Bouchon	Verschluss	Tapón	
	16	80B0 84174	1	Coperchio registri	Cover	Couvercle	Deckel	Tapa	
	17	1615 03601	2	Guarnizione	Gasket	Garnitue	Dichtung	Junta	
	18	8C00 96721	3	Vite (M6x20 mm)	Screw (M6x20 mm)	Vis (M6x20 mm)	Schraube (M6x20 mm)	Tornillo (M6x20 mm)	
	19	1615 14103	1	Tubetto	Tube	Tuyau	Rohr	Tubo	
	20	8000 37299	1	Fascetta	Clamp	Collier	Schelle	Banda	
	21	1615 12802	1	Contentitore vapori basamento	Crankcase vapours cup	Cuve vapeurs carter	Dampfgefäß in dem Kurbelgehäuse	Contenedor vapores cárter	
	22	61N1 15195	1	Dado	Nut	Ecrou	Mutter	Tuerca	
	23	1615 40802	1	Leva	Lever	Levier	Hebel	Palanca	
	24	1615 12301	1	Molla	Spring	Ressort	Feder	Resorte	
	25	80B0 84173	1	Coperchio decompressore	Cover	Couvercle	Deckel	Tapa	
	26	8G00 96721	1	Vite (M6x40 mm)	Screw (M6x40 mm)	Vis (M6x40 mm)	Schraube (M6x40 mm)	Tornillo (M6x40 mm)	
	27	1615 08401	1	Perno	Pin	Pivot	Bolzen	Perno	
	28	1615 08501	1	Camma decompressore	Cam	Came	Nocken	Excéntrico	
	29	8000 21375	1	Anello di fermo	Stop ring	Bague d'arrêt	Haltering	Anillo de retención	
	30	8000 96796	2	Vite (M6x60 mm)	Screw (M6x60 mm)	Vis (M6x60 mm)	Schraube (M6x60 mm)	Tornillo (M6x60 mm)	
	31	8B00 96721	1	Vite (M6x15 mm)	Screw (M6x15 mm)	Vis (M6x15 mm)	Schraube (M6x15 mm)	Tornillo (M6x15 mm)	
	32	8E00 96721	8	Vite (M6x30 mm)	Screw (M6x30 mm)	Vis (M6x30 mm)	Schraube (M6x30 mm)	Tornillo (M6x30 mm)	

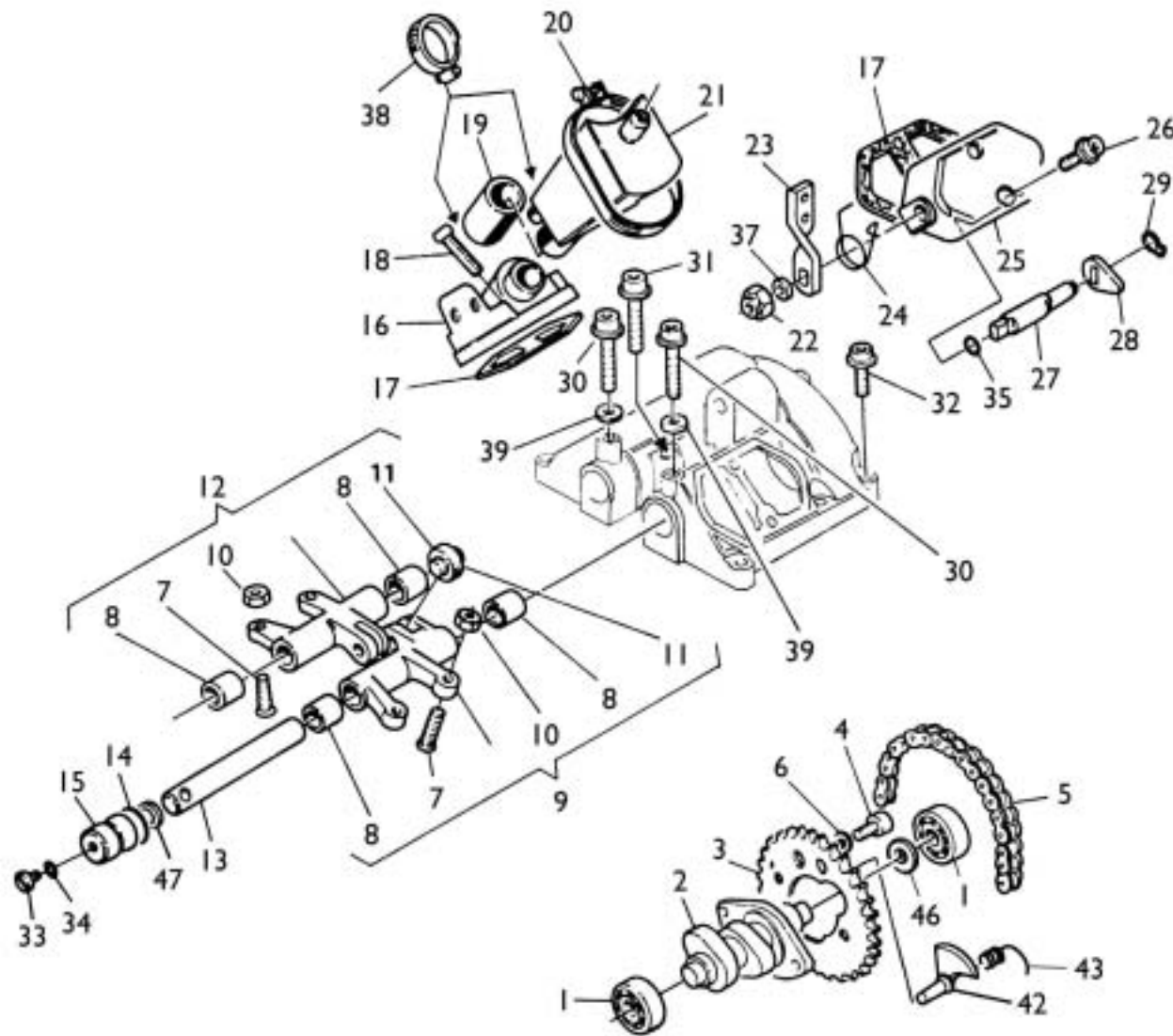

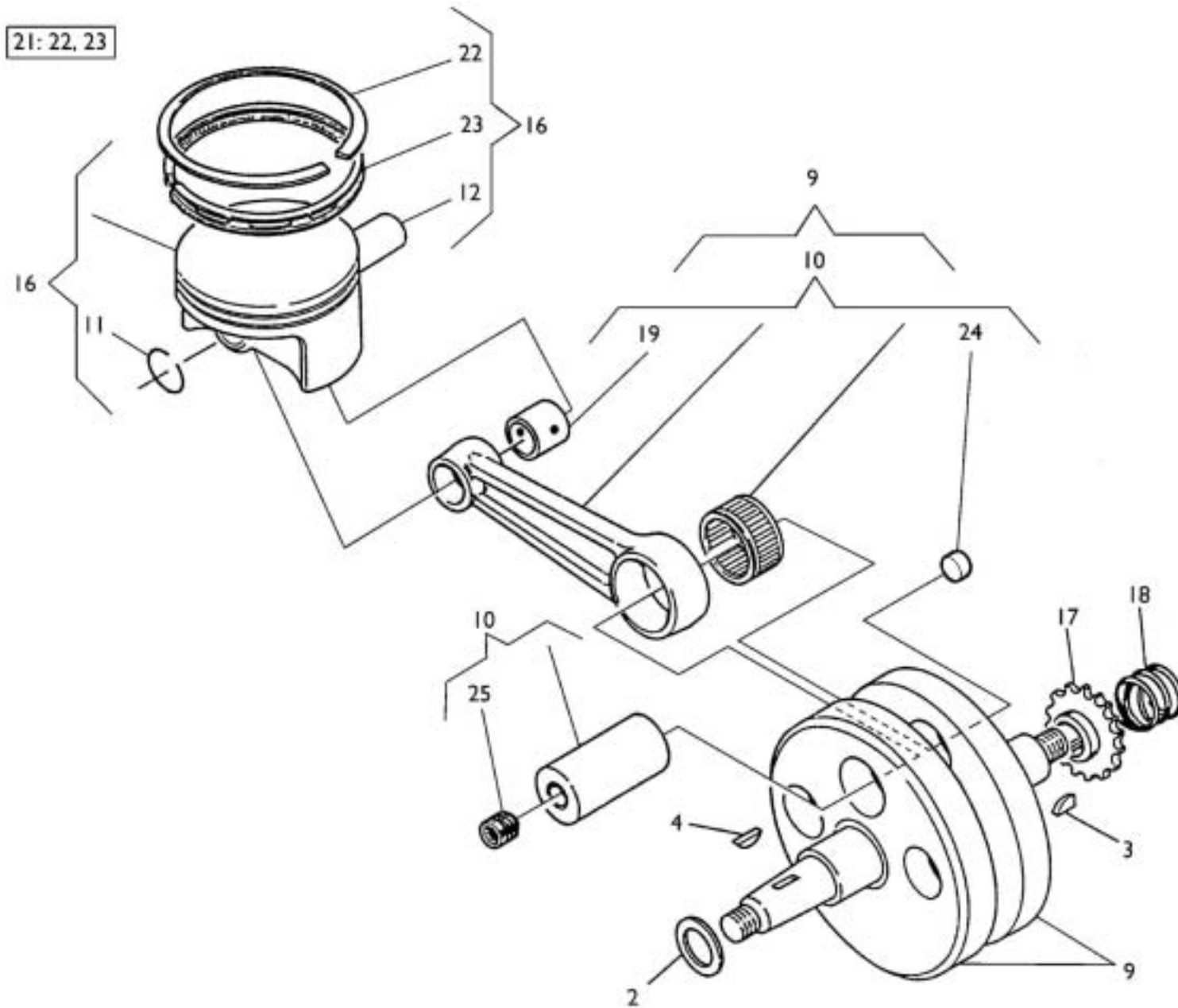



**SMR 630 Seel
replica**

TAVOLA
DRAWING
TABLE
BILD
TABLA

4

**PISTONE, MANOVELLISMO - PISTON, CRANKSHAFT
PISTON, VILEBREQUIN - KOLBEN, KURBELWELLE
PISTON, PALANCAS**

Note Notes Marke Notas	Pos. No. N. Index Pos.	N. Cod. Code No. Nr. Code Code Nr N. Cod.	Q.tà Q.ty Q.te M.ge C.ad	DENOMINAZIONE	NAME	DESIGNATION	BESHREIBUNG	DENOMINACION	Validità Validity Validité Gültig Validez
	2	8A00 28183	1	Rosetta di rasamento (0,3 mm)	Washer (0,3 mm)	Rondelle (0,3 mm)	Scheibe (0,3 mm)	Arandela (0,3 mm)	
	2	8C00 28183	1	Rosetta di rasamento (0,5 mm)	Washer (0,5 mm)	Rondelle (0,5 mm)	Scheibe (0,5 mm)	Arandela (0,5 mm)	
	2	8D00 28183	1	Rosetta di rasamento (0,6 mm)	Washer (0,6 mm)	Rondelle (0,6 mm)	Scheibe (0,6 mm)	Arandela (0,6 mm)	
	2	8F00 28183	1	Rosetta di rasamento (0,8 mm)	Washer (0,8 mm)	Rondelle (0,8 mm)	Scheibe (0,8 mm)	Arandela (0,8 mm)	
	2	8H00 28183	1	Rosetta di rasamento (1,0 mm)	Washer (1,0 mm)	Rondelle (1,0 mm)	Scheibe (1,0 mm)	Arandela (1,0 mm)	
	3	1615 09801	1	Linguetta	Woodruff key	Clé woodruff	Federkeil	Lengüeta	
	4	1513 71301	1	Linguetta	Woodruff key	Clé woodruff	Federkeil	Lengüeta	
	9	8000 A3914	1	Albero motore completo	Crankshaft assy	Vilebrequin compl.	Kurbewelle kpl.	Cigüeñal compl.	
	10	8000 93173	1	Biella completa	Connecting rod compl.	Bielle compl.	Pleuelstange kpl.	Biela motor completa	
	11	8000 67824	2	Anello di fermo	Stop ring	Bague d'arrêt	Haltering	Anillo de retención	
	12	8000 80455	1	Spinotto	Gudgeon	Axe	Bolzen	Perno	
	16	8000 85245	1	Pistone completo (Ø 98 mm)	Compl. piston (Ø 98 mm)	Piston complet (Ø 98 mm)	Kolben, kpl. (Ø 98 mm)	Pistón completo (Ø 98 mm)	
	17	1615 05802	1	Ingranaggio distribuzione	Gear	Engrange	Zahnrad	Engranaje	
	18	8000 61275	1	Molla	Spring	Ressort	Feder	Resorte	
	19	8000 88073	1	Bussola	Bushing	Douille	Buchse	Manguito	
	21	8000 77715	1	Kit segmenti	Circlip kit	Kit segment	Kolbenring kit	Kit segmento	
N	22	a	1	Segmento	Circlip	Ségment	Kolbenring	Segmento	
N	23	a	1	Raschiaolio	Scraper ring	Ségment racleur huile	Ölabstreifring	Rascador aceite	
	24	8000 57196	1	Tappo	Plug	Bouchon	Verschluss	Tapòn	
	25	8A00 45395	1	Tappo filettato	Threaded plug	Bouchon fileté	Gewindepfropf	Tapòn filete	
		a		Forniti in gruppo pos.21	Supplied in bag ref. N° 21	Son fournies en unités pos. 21	Sind im Umschlag Bez. Nr 21	Provisto en grupo pos. 21	

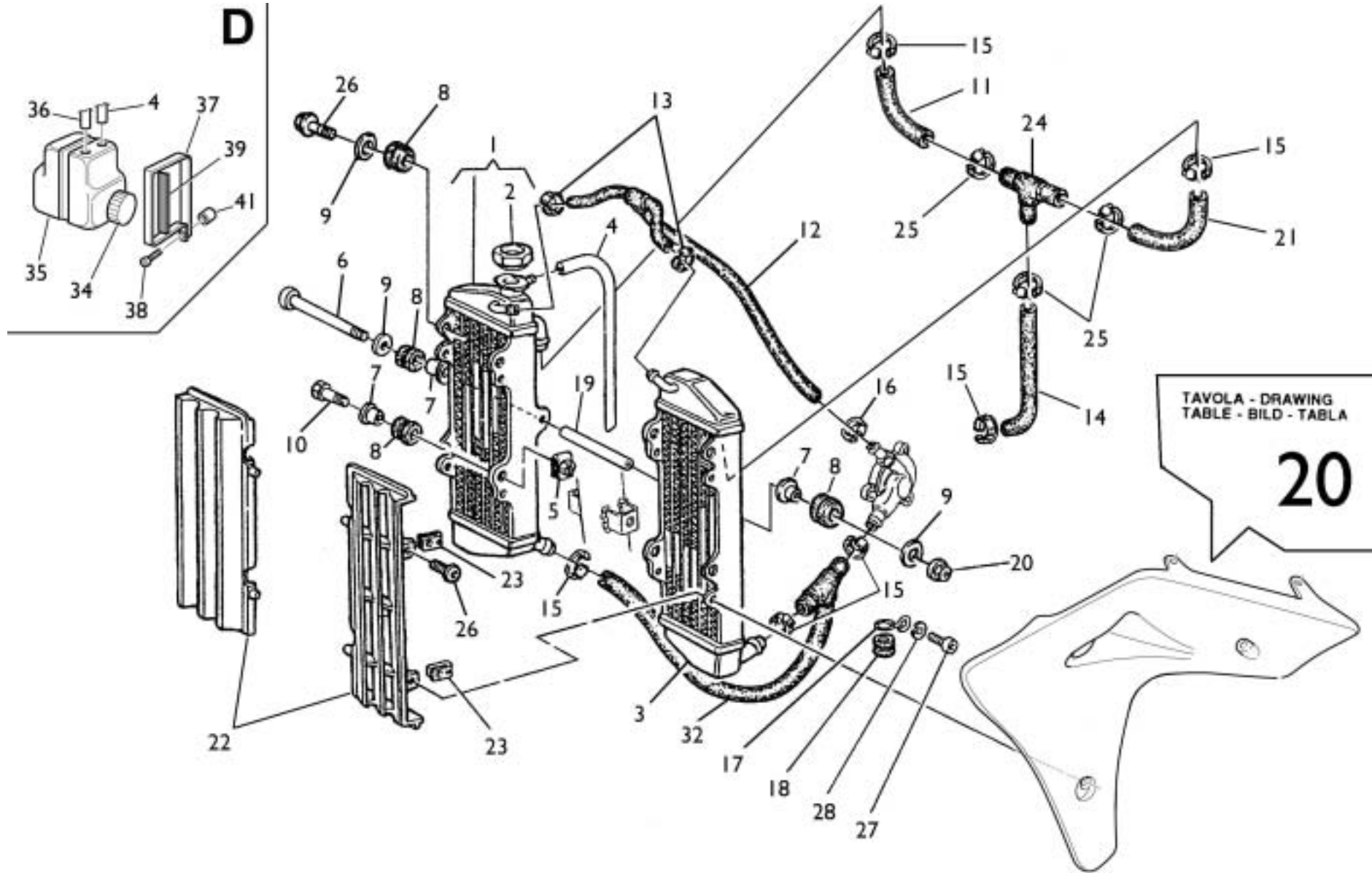



**SMR 630 Seel
replica**

TAVOLA
DRAWING
TABLE
BILD
TABLA

5

**RAFFREDDAMENTO - COOLING
REFROIDISSEMENT - WASSERKÜHLUNG
ENFRIAMIENTO**

Note Notes Marke Notas	Pos. No. N. Index Pos.	N. Cod. Code No. Nr. Code Code Nr N. Cod.	Q.tà Q.ty Q.te M.ge C.ad	DENOMINAZIONE	NAME	DESIGNATION	BESHREIBUNG	DENOMINACION	Validità Validity Validité Gültig Validez
	1	8000 99658	1	Radiatore Dx. completo	R.H. radiator compl.	Radiateur D. compl.	R., Kühler kpl.	Radiador derech. compl.	
	2	8000 79077	1	Tappo	Plug	Bouchon	Verschluss	Tapón	
	3	8000 87120	1	Radiatore Sx.	L.H. radiator	Radiateur G.	L., Kühler	Radiador izrdo.	
	4	8000 43715	1	Tubetto sfiato L=400	Tube L=400	Tuyau L=400	Rohr L=400	Tube L=400	
D	4	8B00 43715	1	Tubetto sfiato L=660	Tube L=660	Tuyau L=660	Rohr L=660	Tube L=660	
	5	8000 46893	2	Dado a graffetta	Nut	Ecrou	Mutter	Tuerca	
	6	60N1 02525	1	Vite (M6x100 mm)	Screw (M6x100 mm)	Vis (M6x100 mm)	Schraube (M6x100 mm)	Tornillo (M6x100 mm)	
	7	8000 59802	4	Bussola	Bushing	Douille	Buchse	Manguito	
	8	8000 59803	6	Gommino	Rubber pad	Pièce caoutchouc	Gummstück	Junta de goma	
	9	8000 59801	4	Rosetta piana	Washer	Rondelle	Scheibe	Arandela	
	10	8000 62728	2	Vite (M6x20 mm)	Screw (M6x20 mm)	Vis (M6x20 mm)	Schraube (M6x20 mm)	Tornillo (M6x20 mm)	
	11	8000 A3912	1	Tubo	Pipe	Tuyau	Schlauch	Tube	
	12	8B00 66850	1	Tubo	Pipe	Tuyau	Schlauch	Tube	
	13	8000 57242	2	Fascetta	Clamp	Collier	Schelle	Banda	
	14	8000 A3911	1	Tubo cilindro - radiatori	Pipe	Tuyau	Schlauch	Tube	
	15	8B00 99475	6	Fascetta	Clamp	Collier	Schelle	Banda	
	16	8B00 91687	1	Fascetta	Clamp	Collier	Schelle	Banda	
	17	8000 87859	1	Anello di guida	Ring	Bague	Ring	Anillo	
	18	8000 67449	1	Gommino	Rubber pad	Pièce caoutchouc	Gummstück	Junta de goma	
	19	8000 66858	1	Distanziale	Spacer	Entretoise	Distanzstück	Separador	
	20	8000 44240	1	Dado	Nut	Ecrou	Mutter	Tuerca	
	21	8000 A3913	1	Tubo	Pipe	Tuyau	Schlauch	Tube	
	22	80A0 67248	2	Griglia	Grille	Grille	Gitter	Parilla	
	23	8000 60873	4	Dado a graffetta	Nut	Ecrou	Mutter	Tuerca	
	24	8000 A0671	1	Raccordo	Union	Raccord	Anschluss	Empalme	
	25	8000 50453	3	Fascetta	Clamp	Collier	Schelle	Banda	
	26	8000 62725	2	Vite (M6x10 mm)	Screw (M6x10 mm)	Vis (M6x10 mm)	Schraube (M6x10 mm)	Tornillo (M6x10 mm)	
	27	8000 62725	1	Vite (M6x10 mm)	Screw (M6x10 mm)	Vis (M6x10 mm)	Schraube (M6x10 mm)	Tornillo (M6x10 mm)	
	28	62N1 15519	1	Rosetta piana	Washer	Rondelle	Scheibe	Arandela	
	32	8A00 72284	1	Ass. tubo	Pipe	Tuyau	Schlauch	Tube	
D	34	8000 40427	1	Tappo	Plug	Bouchon	Verschluss	Tapón	
D	35	8000 41758	1	Serbatoio espansione	Expansion tank	Vase d'expansion	Ausdehnungsgefäß	Depósito expansión	
D	36	8C00 43715	1	Tubo L=850	Pipe L=850	Tuyau L=850	Schlauch L=850	Tube L=850	

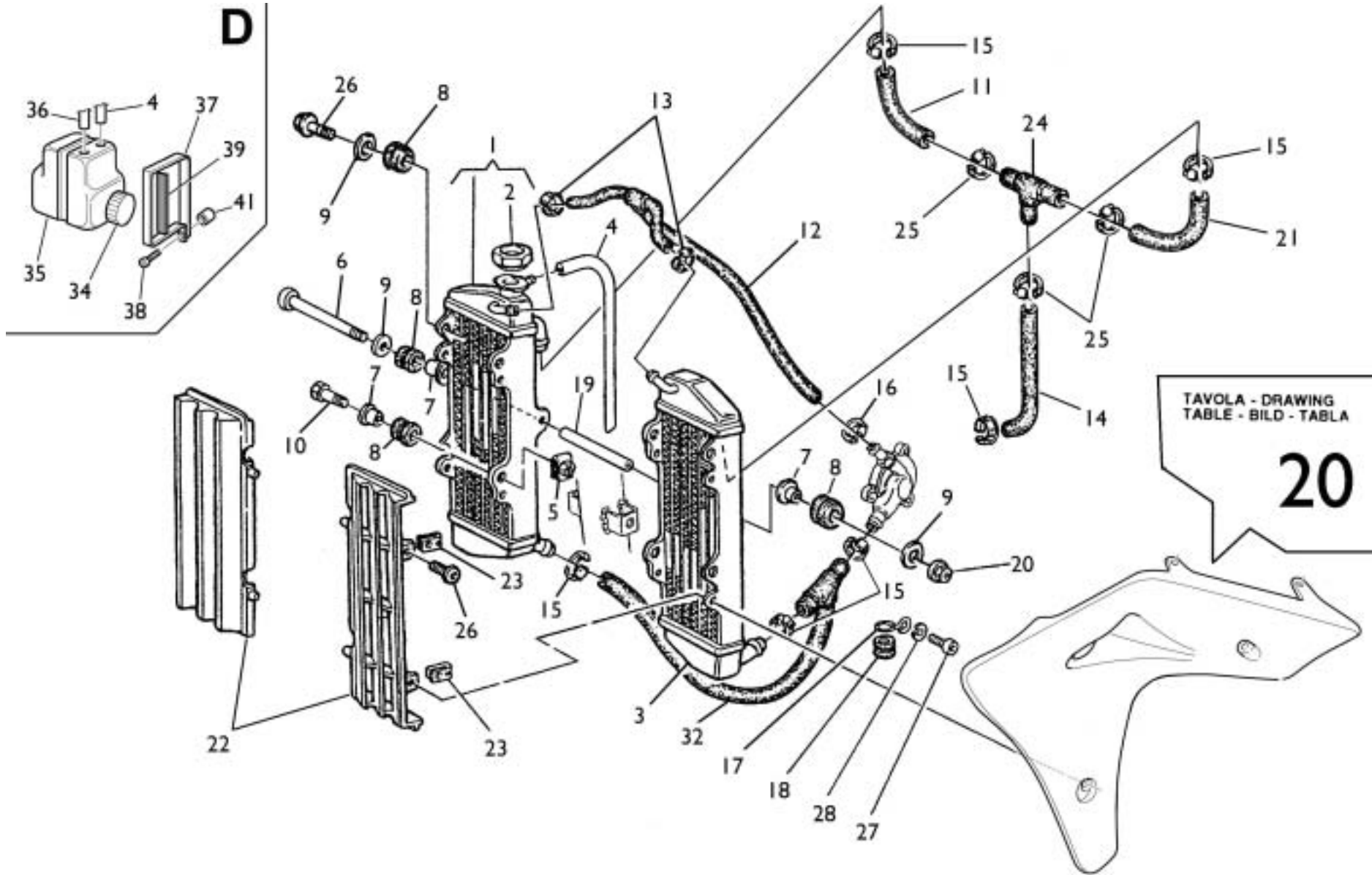

35: 3+5, 7, 9, 10, 13, 17, 25, 27, 32, 33

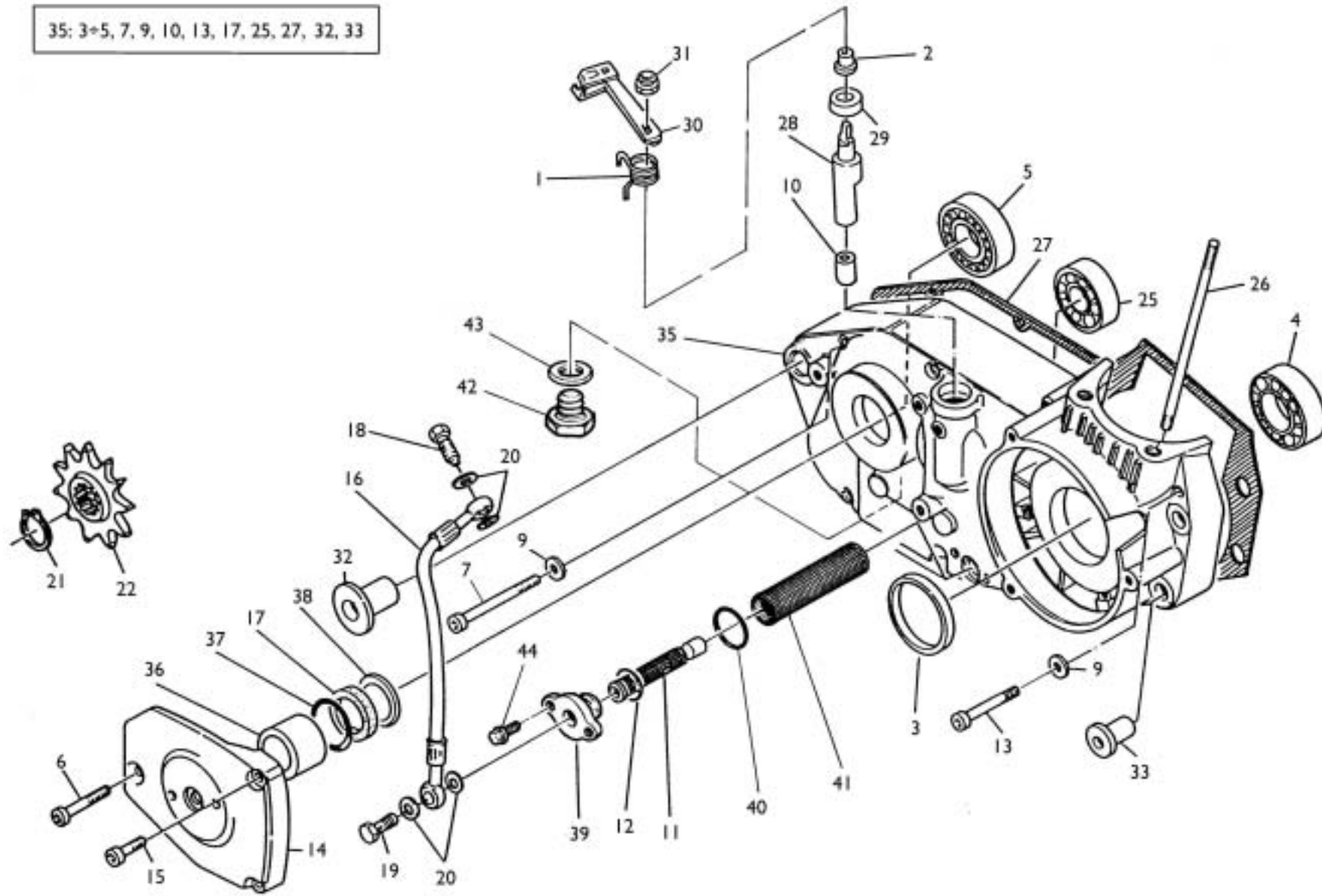



**SMR 630 Seel
replica**

TAVOLA
DRAWING
TABLE
BILD
TABLA

6

**SEMICARTER DESTRO - R.H. HALF CRANKCASE
CARTER D. - GEHAUSEDECKEL R.
BANCADA DER.**

Note Notes Notes Markes Notas	Pos. No. N. Index Pos.	N. Cod. Code No. Nr. Code Code Nr N. Cod.	Q.tà Q.ty Q.te M.ge C.ad	DENOMINAZIONE	NAME	DESIGNATION	BESHREIBUNG	DENOMINACION	Validità Validity Validité Gültig Validez
	1	8A00 48188	1	Molla	Spring	Ressort	Feder	Resorte	
	2	8A00 55532	1	Bussola	Bushing	Douille	Buchse	Manguito	
	3	1513 72602	1	Anello di tenuta (ø30xØ52x7 mm)	Seal ring (ø30xØ52x7 mm)	Bague d'étanchéité (ø30xØ52x7 mm)	Dichtungsring (ø30xØ52x7 mm)	Anillo de retención (ø30xØ52x7 mm)	
	4	8000 28182	1	Cuscinetto (ø30xØ72x19 mm)	Bearing (ø30xØ72x19 mm)	Roulement (ø30xØ72x19 mm)	Lager (ø30xØ72x19 mm)	Cojinete (ø30xØ72x19 mm)	
	5	8000 43789	1	Cuscinetto (ø25xØ52x15 mm)	Bearing (ø25xØ52x15 mm)	Roulement (ø25xØ52x15 mm)	Lager (ø25xØ52x15 mm)	Cojinete (ø25xØ52x15 mm)	
	6	60N1 02513	1	Vite (M6X40 mm)	Screw (M6X40 mm)	Vis (M6X40 mm)	Schraube (M6X40 mm)	Tornillo (M6X40 mm)	
	7	8S00 96718	6	Vite (M6X75 mm)	Screw (M6X75 mm)	Vis (M6X75 mm)	Schraube (M6X75 mm)	Tornillo (M6X75 mm)	
	9	62N1 15504	9	Rosetta piana	Washer	Rondelle	Scheibe	Arandela	
	10	8000 68195	1	Bussola	Bushing	Douille	Buchse	Manguito	
	11	8000 72427	1	Filtro olio interno	Internal oil filter	Filtre à huile	Ölfiler	Filtro aceite	
	12	8000 26884	1	Anello di tenuta	Seal ring	Bague d'étanchéité	Dichtungsring	Anillo de retención	
	13	8L00 96718	3	Vite (M6X50 mm)	Screw (M6X50 mm)	Vis (M6X50 mm)	Schraube (M6X50 mm)	Tornillo (M6X50 mm)	
	14	1611 81604	1	Coperchio	Cover	Couvercle	Deckel	Tapa	
	15	60N1 02510	2	Vite (M6X25 mm)	Screw (M6X25 mm)	Vis (M6X25 mm)	Schraube (M6X25 mm)	Tornillo (M6X25 mm)	
	16	8000 65653	1	Tubo	Pipe	Tuyau	Schlauch	Tubo	
	17	8000 59977	1	Anello di tenuta (ø32xØ40x5 mm)	Seal ring (ø32xØ40x5 mm)	Bague d'étanchéité (ø32xØ40x5 mm)	Dichtungsring (ø32xØ40x5 mm)	Anillo de retención (ø32xØ40x5 mm)	
	18	8000 96729	1	Vite	Screw	Vis	Schraube	Tornillo	
	19	8000 96728	1	Vite	Screw	Vis	Schraube	Tornillo	
	20	8000 21480	4	Rosetta	Washer	Rondelle	Scheibe	Arandela	
	21	66N0 21211	1	Anello di fermo	Stop ring	Bague d'arrêt	Haltering	Anillo de retención	
D	22	8000 63829	1	Pignone (Z=14)	Pinion (Z=14)	Pignon (Z=14)	Ritzel (Z=14)	Piñón (Z=14)	
	22	8000 63831	1	Pignone (Z=16)	Pinion (Z=16)	Pignon (Z=16)	Ritzel (Z=16)	Piñón (Z=16)	
	25	8000 19768	1	Cuscinetto (ø15xØ42x13 mm)	Bearing (ø15xØ42x13 mm)	Roulement (ø15xØ42x13 mm)	Lager (ø15xØ42x13 mm)	Cojinete (ø15xØ42x13 mm)	
	26	1615 11602	4	Prigioniero cilindro	Stud bolt	Prisonnier	Stiftschraube	Prisionero	
	27	1615 01404	1	Guarnizione	Gasket	Garnitue	Dichtung	Junta	
	28	8A00 68201	1	Albero comando frizione	Shaft	Arbre	Welle	Eje	
	29	1513 72201	1	Anello di tenuta (ø10xØ22x8 mm)	Seal ring (ø10xØ22x8 mm)	Bague d'étanchéité (ø10xØ22x8 mm)	Dichtungsring (ø10xØ22x8 mm)	Anillo de retención (ø10xØ22x8 mm)	
	30	8A00 68196	1	Leva	Lever	Levier	Hebel	Palanca	
	31	8000 56410	1	Dado	Nut	Ecrou	Mutter	Tuerca	

35: 3-5, 7, 9, 10, 13, 17, 25, 27, 32, 33

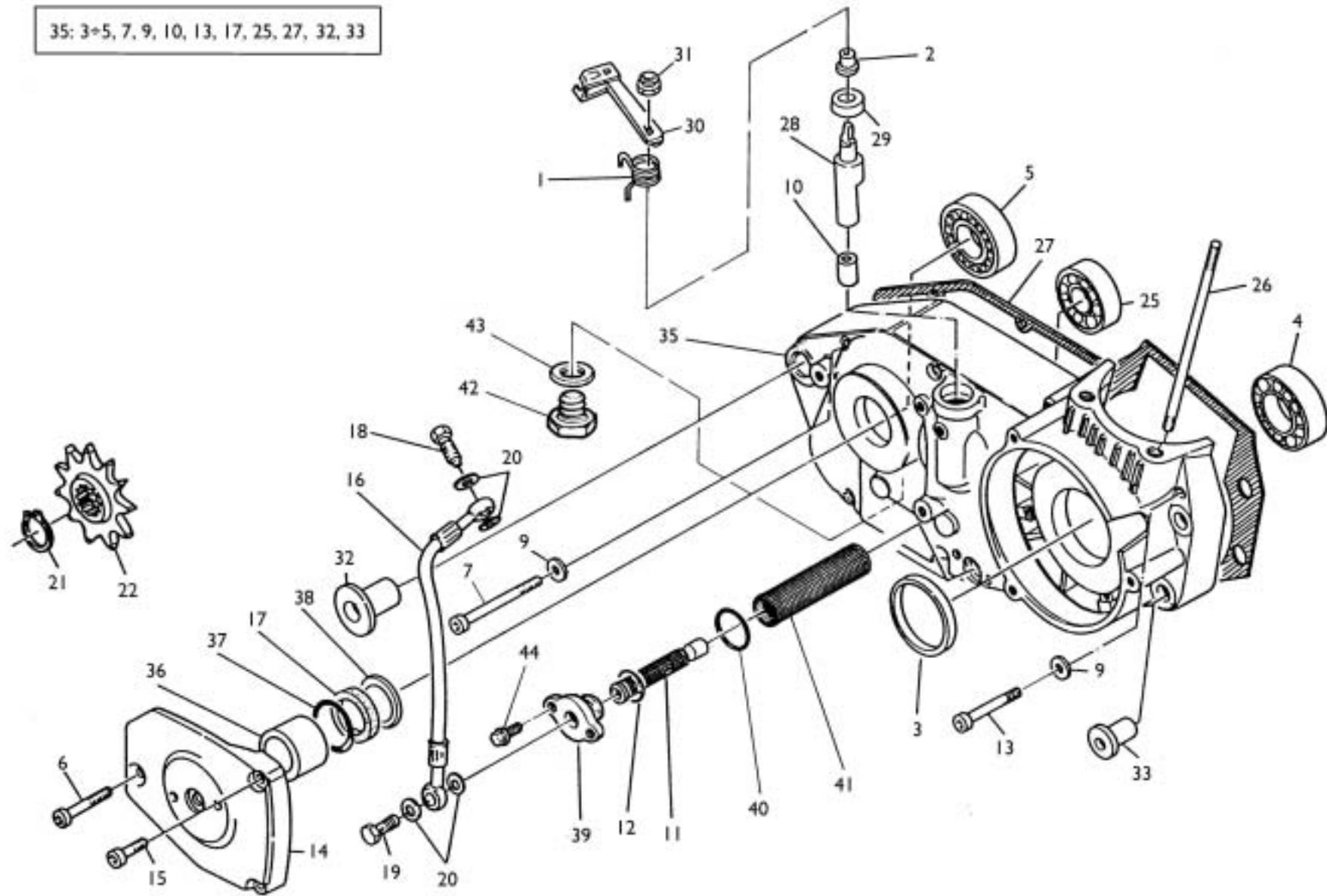

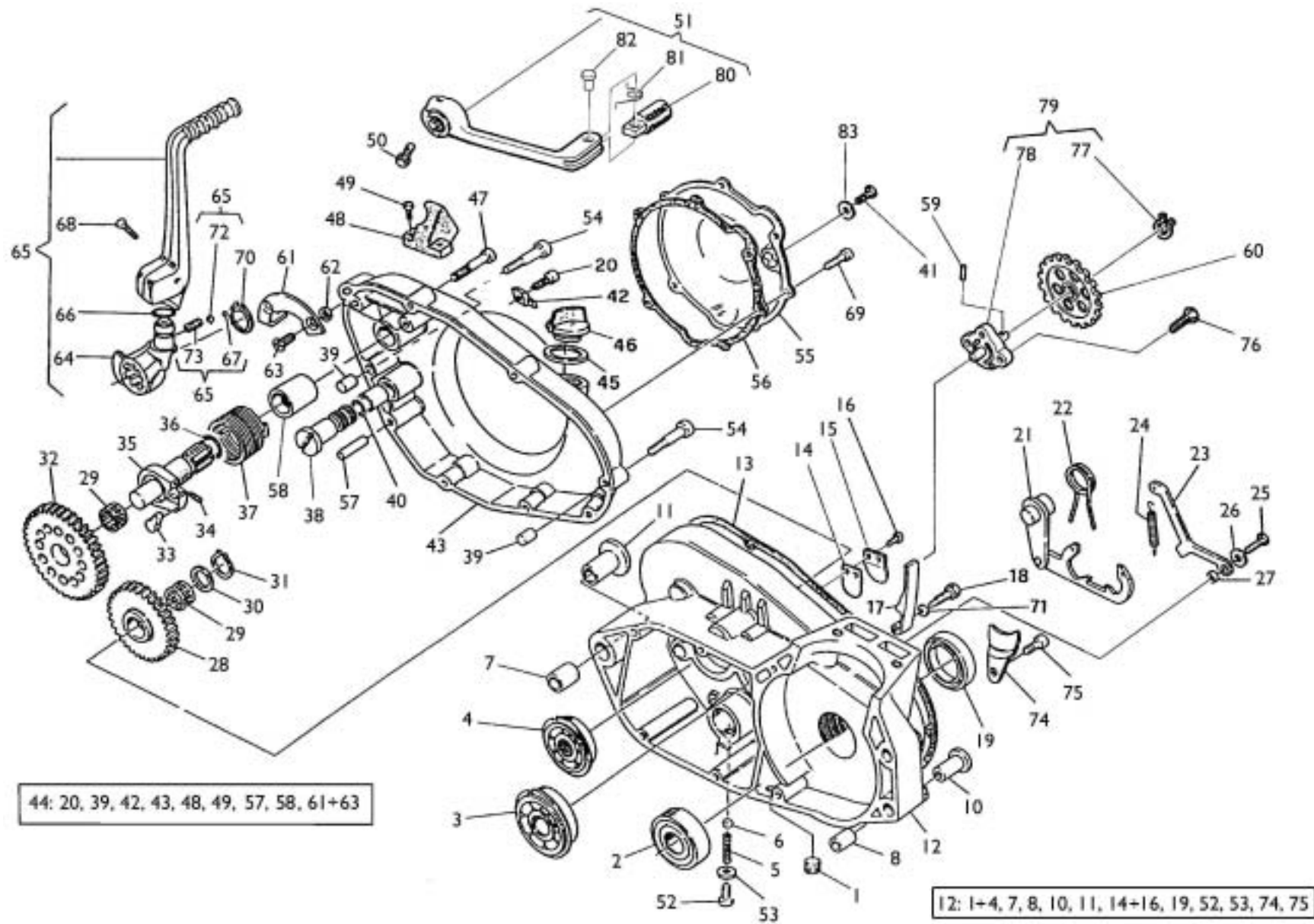



**SMR 630 Seel
replica**

TAVOLA
DRAWING
TABLE
BILD
TABLA

7

**SEMICARTER SIN., AVVIAMENTO - L.H. HALF CRANKCASE, STARTING
CARTER G., DEMARRAGE - GEHAUSEDECKEL L., ANLASSER
BANCADA IZQ., ARRANQUE**

Note Notes Notas	Pos. No. N. Index Pos.	N. Cod. Code No. Nr. Code Code Nr N. Cod.	Q.tà Q.ty Q.te M.ge C.ad	DENOMINAZIONE	NAME	DESIGNATION	BESHREIBUNG	DENOMINACION	Validità Validity Validité Gültig Validez
	1	8000 69769	1	Tappo	Plug	Bouchon	Verschluss	Tapón	
	2	8A00 28182	1	Cuscinetto (ø30xø72x19 mm)	Bearing (ø30xø72x19 mm)	Roulement (ø30xø72x19 mm)	Lager (ø30xø72x19 mm)	Cojinete (ø30xø72x19 mm)	
	3	8000 59975	1	Cuscinetto (ø25xø52x15 mm)	Bearing (ø25xø52x15 mm)	Roulement (ø25xø52x15 mm)	Lager (ø25xø52x15 mm)	Cojinete (ø25xø52x15 mm)	
	4	8000 59976	1	Cuscinetto (ø17xø47x14 mm)	Bearing (ø17xø47x14 mm)	Roulement (ø17xø47x14 mm)	Lager (ø17xø47x14 mm)	Cojinete (ø17xø47x14 mm)	
	5	8000 61263	1	Molla	Spring	Ressort	Feder	Resorte	
	6	8000 60476	1	Sfera	Ball	Bille	Kugel	Esfera	
	7	1614 59002	1	Bussola di riferimento	Bushing	Douille	Buchse	Manguito	
	8	1610 77601	1	Bussola di riferimento	Bushing	Douille	Buchse	Manguito	
	10	1610 77701	2	Bussola	Bushi,g	Douille	Buchse	Manguito	
	11	8B00 71154	1	Bussola	Bushing	Douille	Buchse	Manguito	
	12	8000 98179	1	Carter motore accoppiati compl.	Crankcase assy	Carter compl.	Kurberlgehaue kpl.	Carter motor completi	
	13	1611 65003	1	Guarnizione	Gasket	Garnitue	Dichtung	Junta	
	14	1615 34801	1	Valvola lamellare	Reed valve	Soupape lamellaire	Ventil lamellar	Válvula laminar	
	15	1615 10501	1	Supporto	Support	Support	Halterung	Soporte elástico	
	16	60N1 02866	2	Vite	Screw	Vis	Schraube	Tornillo	
	17	8000 68686	1	Tendicatena distr.	Chain adjuster	Tendeur de chaine	Kettenspanner	Tensor de cadena	
	18	8000 92838	1	Vite	Screw	Vis	Schraube	Tornillo	
	19	1513 72602	1	Anello di tenuta (ø30xø52x7 mm)	Seal ring (ø30xø52x7 mm)	Bague d'étanchéité (ø30xø52x7 mm)	Dichtungsring (ø30xø52x7 mm)	Anillo de retención (ø30xø52x7 mm)	
	20	8A00 96724	1	Vite	Screw	Vis	Schraube	Tornillo	
	21	1611 68601	1	Selettore cambio	Selector	Selecteur	Waehler	Selector com.	
	22	1611 69201	1	Molla	Spring	Ressort	Feder	Resorte	
	23	8000 90054	1	Saltarello	Click	Cliquet	Strumhaken	Saltarelo	
	24	1611 68401	1	Molla	Spring	Ressort	Feder	Resorte	
	25	8000 47422	1	Vite	Screw	Vis	Schraube	Tornillo	
	26	8A00 37003	1	Rosetta piana	Washer	Rondelle	Scheibe	Arandela	
	27	1611 21601	1	Bussola	Bushing	Douille	Buchse	Manguito	
	28	1611 27101	1	Ingranaggio di rinvio (Z=25)	Gear (Z=25)	Engranaage (Z=25)	Zahnrad (Z=25)	Engranaje (Z=25)	
	29	8000 40449	2	Cuscinetto a rullini	Needle bearing	Roulement à aiguilles	Nadelkäfig	Cojinete de rodillos	

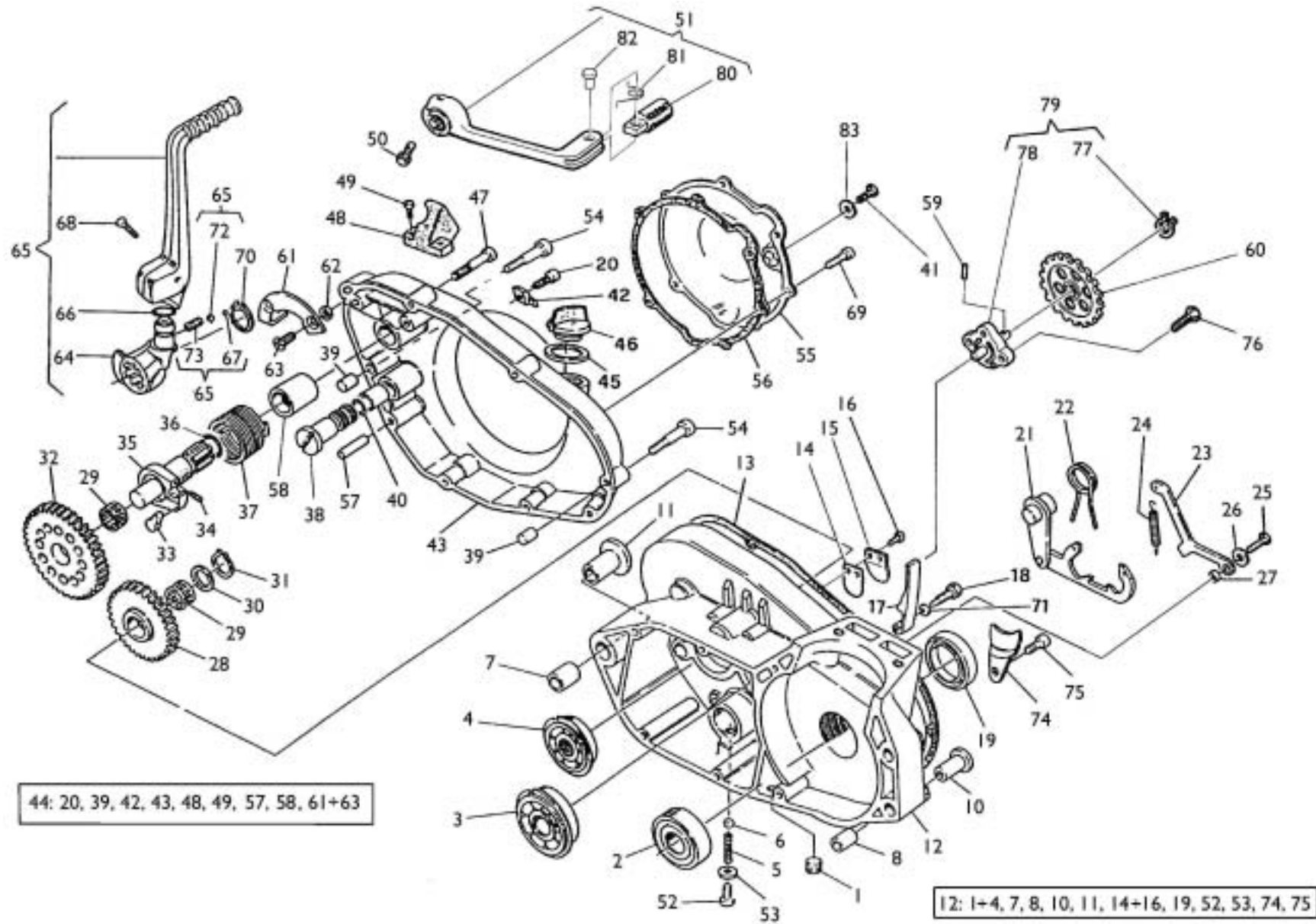



**SMR 630 Seel
replica**

TAVOLA
DRAWING
TABLE
BILD
TABLA

7

**SEMICARTER SIN., AVVIAMENTO - L.H. HALF CRANKCASE, STARTING
CARTER G., DEMARRAGE - GEHAUSEDECKEL L., ANLASSER
BANCADA IZQ., ARRANQUE**

Note Notes Notes Markes Notas	Pos. No. N. Index Pos.	N. Cod. Code No. Nr. Code Code Nr N. Cod.	Q.tà Q.ty Q.te M.ge C.ad	DENOMINAZIONE	NAME	DESIGNATION	BESHREIBUNG	DENOMINACION	Validità Validity Validité Gültig Validez
	30	8000 38110	1	Rosetta di rasamento (0,3 mm)	Washer (0,3 mm)	Rondelle (0,3 mm)	Scheibe (0,3 mm)	Arandela (0,3 mm)	
	30	8B00 38110	1	Rosetta di rasamento (0,5 mm)	Washer (0,5 mm)	Rondelle (0,5 mm)	Scheibe (0,5 mm)	Arandela (0,5 mm)	
	30	8F00 38110	1	Rosetta di rasamento (1,0 mm)	Washer (1,0 mm)	Rondelle (1,0 mm)	Scheibe (1,0 mm)	Arandela (1,0 mm)	
	31	66N0 21205	1	Anello di fermo	Stop ring	Bague d'arrêt	Haltering	Anillo de retención	
	32	1615 39101	1	Ingranaggio avviamento (Z=35)	Driven gear (Z=35)	Engranage conduit (Z=35)	Zahnrad (Z=35)	Engranaje conducto (Z=35)	
	33	1611 68001	1	Saltarello	Click	Cliquet	Strumhaken	Saltarelo	
	34	1611 68101	1	Molla	Spring	Ressort	Feder	Resorte	
	35	1611 67702	1	Albero avviamento	Starter crank shaft	Arbre de démarrage	Kickstarterwelle	Eje arranque	
	36	8000 60475	2	Anello OR	O-Ring	Bague OR	O-Ring	Anillo OR	
	37	1616 36201	1	Molla	Spring	Ressort	Feder	Resorte	
	38	1611 74601	1	Albero pedale cambio	Gearbox pedal shaft	Arbre pédale change vitesse	Pedal Umsteuerungswelle	Eje pedal cambio	
	39	1611 70801	2	Spina di riferimento	Pin	Goupille	Stift	Clavija	
	40	8000 60474	2	Anello OR	O-Ring	Bague OR	O-Ring	Anillo OR	
	41	8000 96727	1	Vite livello olio	Oil level screw	Vis controle huile	Olcontrolschraube	Tornillo nivel aceite	
	42	8000 68710	1	Gommino	Rubber pad	Pièce caoutchouc	Gummstück	Junta de goma	
	44	8000 98180	1	Coperchio trasmissione compl.	Cover assy	Couvercle compl.	Deckel Kpl.	Tapa compl.	
	45	8000 27960	1	Guarnizione	Gasket	Garnitue	Dichtung	Junta	
	46	8000 36786	1	Tappo	Plug	Bouchon	Verschluss	Tapón	
	47	8F00 96718	6	Vite (M6X35 mm)	Screw (M6X35 mm)	Vis (M6X35 mm)	Schraube (M6X35 mm)	Tornillo (M6X35 mm)	
	48	8000 68584	1	Tampone ferma pedale	Pad	Tampon	Stopfen	Tampón	
	49	8B00 96717	2	Vite	Screw	Vis	Schraube	Tornillo	
	50	8C00 96718	1	Vite	Screw	Vis	Schraube	Tornillo	
	51	8000 92944	1	Leva cambio compl.	Gearchange lever	Levier comm. vitesse	Schalthebel	Palanca del cambio	
	52	8000 66101	1	Vite	Screw	Vis	Schraube	Tornillo	
	53	8000 47763	1	Bussola	Bushing	Douille	Buchse	Manguito	
	54	8G00 96718	2	Vite (M6X40 mm)	Screw (M6X40 mm)	Vis (M6X40 mm)	Schraube (M6X40 mm)	Tornillo (M6X40 mm)	
	55	80A0 96889	1	Coperchio	Cover	Couvercle	Deckel	Tapa	
	56	8000 96890	1	Guarnizione	Gasket	Garnitue	Dichtung	Junta	
	57	8000 60477	1	Spina di riferimento	Pin	Goupille	Stift	Clavija	
	59	8C00 27690	1	Rullino	Roller	Aiguille	Rolle	Rodillo	
	60	8000 90052	1	Ingranaggio pompa	Pump gear	Engrenage	Zahnrad	Engranaje	
	61	1611 70401	1	Piastrina fine corsa	Plate	Plaquette	Plättchen	Placa	
	62	1611 70601	2	Distanziale	Spacer	Entretoise	Distanzstück	Separador	

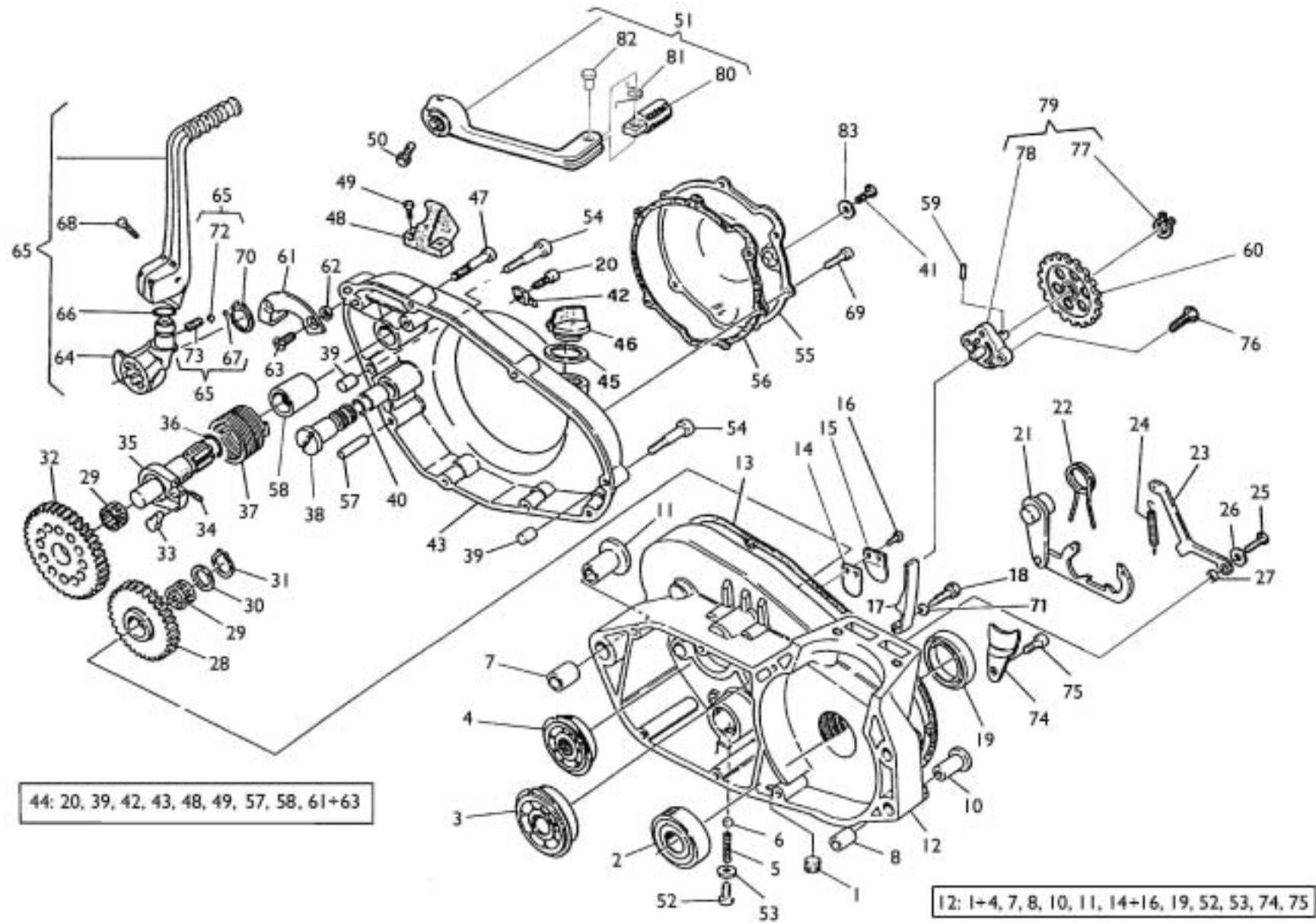

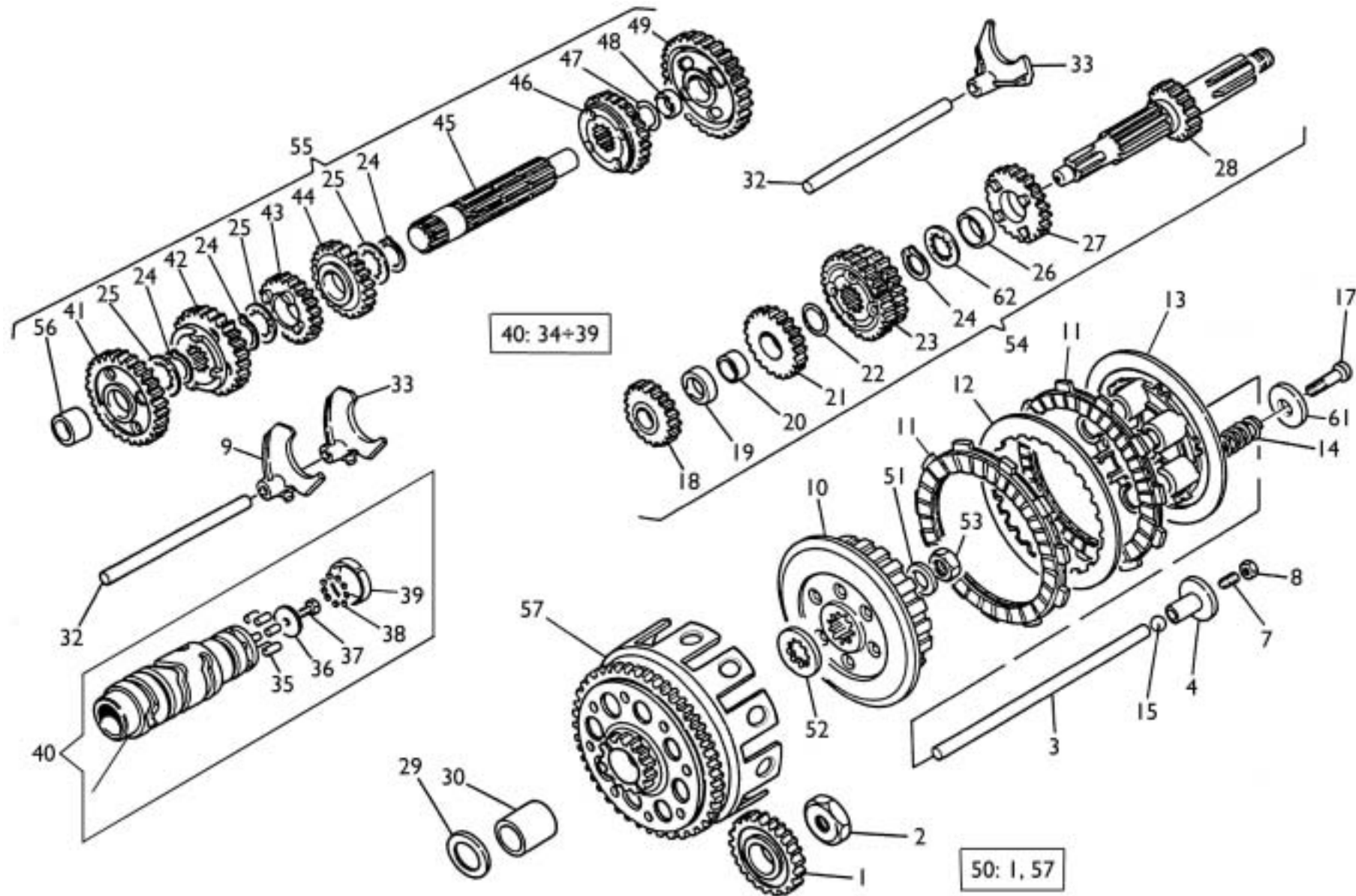



**SMR 630 Seel
replica**

TAVOLA
DRAWING
TABLE
BILD
TABLA

8

**CAMBIO, COMANDO CAMBIO, FRIZIONE - TRANSMISSION, SHIFTER, CLUTCH
BOITE DE VITESSE, COMMANDE DE VITESSE, EMBRAYAGE
WECHSELGETRIEBE, GANGSCHALTUNG, KUPPLUNG - CAMBIO, MANDO CAMBIO, EMBRAGUE**

Note Notes Marke Notas	Pos. No. N. Index Pos.	N. Cod. Code No. Nr. Code Code Nr N. Cod.	Q.tà Q.ty Q.te M.ge C.ad	DENOMINAZIONE	NAME	DESIGNATION	BESHREIBUNG	DENOMINACION	Validità Validity Validité Gültig Validez
	1	8000 93116	1	Ingranaggio conduttore	Driving gear	Engranaage conducteur	Zahnrad	Engranaje conductor	
	2	8000 59965	1	Dado	Nut	Ecrou	Mutter	Tuerca	
	3	1615 31502	1	Asta di forza	Fork tube	Barre de force	Druckstab	Varilla de fuerza	
	4	8000 54477	1	Piattello	Plate	Plateau	Teller	Placa	
	7	8000 54692	1	Vite	Screw	Vis	Schraube	Tornillo	
	8	61N1 15062	1	Dado	Nut	Ecrou	Mutter	Tuerca	
	9	8000 63425	1	Forcella 3ª vel.	Fork	Fourche	Gabel	Horquilla	
	10	8000 83333	1	Mozzo frizione	Hub	Moyeau	Radnabe	Cubo	
	11	8000 88967	7	Disco conduttore	Driving disc	Disque conducteur	Belagscheibe	Disco conductor	
	12	8000 88968	6	Disco condotto	Driven disc	Disque conduit	Stahlscheibe	Disco conducido	
	13	8000 48138	1	Piastra spingidisci	Plate	Plaque	Platte	Placa	
	14	8000 71230	6	Molla frizione	Clutch spring	Ressort embrayage	Kupplungsfeder	Resorte embrague	
	15	6BN0 21509	1	Sfera	Ball	Bille	Kugel	Esfera	
	17	60N1 01081	6	Vite	Screw	Vis	Schraube	Tornillo	
	18	1612 36201	1	Ingranaggio 2ª A.P. (Z=16)	Main shaft 2nd gear (Z=16)	Engrenage 2ème vitesse A.P. (Z=16)	Zahnw. f. 2. Geschw. . (Z=16)	Engranaje 2º velocidad Eje P. (Z=16)	
	19	1612 48101	1	Distanziale	Spacer	Entretoise	Distanzstück	Separador	
	20	1612 48001	1	Bussola	Bushing	Douille	Buchse	Manguito	
	21	1612 36301	1	Ingranaggio 3ª A.P. (Z=19)	Main shaft 3rd gear (Z=19)	Engrenage 3ème vitesse A.P. (Z=19)	Zahnw. f. 3. Geschw. Antriebsw. (Z=19)	Engranaje 3º velocidad Eje P. (Z=19)	
	22	1612 84201	1	Rosetta	Washer	Rondelle	Scheibe	Arandela	
	23	1612 39001	1	Ingran. 5ª e 6ª A.P. (Z=25/27)	Gear 5th - 6th speed (Z=25/27)	Engranaage 5ème 6ème (Z=25/27)	Zahnrad 5. - 6. Gang (Z=25/27)	Engranaje 5º - 6º velocidad (Z=25/27)	
	24	66N0 21211	4	Anello di fermo	Stop ring	Bague d'arrêt	Haltering	Anillo de retención	
	25	1611 71701	3	Rosetta	Washer	Rondelle	Scheibe	Arandela	
	26	8000 63821	1	Bussola	Bushing	Douille	Buchse	Manguito	
	27	1611 83701	1	Ingranaggio 4ª A.P. (Z=23)	Main shaft 4th gear (Z=23)	Engrenage 4ème vitesse A.P. (Z=23)	Zahnw. f. 4. Geschw. Antriebsw. (Z=23)	Engranaje 4º velocidad Eje P. (Z=23)	
	28	8000 69736	1	Albero primario	Main shaft	Arbre primaire	Hauptwelle	Eje primario	
	29	8E00 30053	1	Rosetta di rasamento	Washer	Rondelle	Scheibe	Arandela	
	30	1615 38801	1	Bussola	Bushing	Douille	Buchse	Manguito	
	32	1611 69901	2	Perno	Pin	Pivot	Bolzen	Perno	
	33	1612 38401	2	Forcella cambio	Fork	Fourche	Gabel	Horquilla	



**SMR 630 Seel
replica**

TAVOLA
DRAWING
TABLE
BILD
TABLA

8

**CAMBIO, COMANDO CAMBIO, FRIZIONE - TRANSMISSION, SHIFTER, CLUTCH
BOITE DE VITESSE, COMMANDE DE VITESSE, EMBRAYAGE
WECHSELGETRIEBE, GANGSCHALTUNG, KUPPLUNG - CAMBIO, MANDO CAMBIO, EMBRAGUE**

Note Notes Notas	Pos. No. Index Pos.	N. Cod. Code No. Nr. Code Code Nr N. Cod.	Q.tà Q.ty Q.te M.ge C.ad	DENOMINAZIONE	NAME	DESIGNATION	BESHREIBUNG	DENOMINACION	Validità Validity Validité Gültig Validez
	35	8000 35823	6	Rullino	Roller	Aiguille	Rolle	Rodillo	
	36	8000 30326	1	Rosetta	Washer	Rondelle	Scheibe	Arandela	
	37	8000 60473	1	Vite	Screw	Vis	Schraube	Tornillo	
	38	8000 60472	11	Sfera	Ball	Bille	Kugel	Esfera	
	39	1612 69901	1	Anello esterno	Ring	Bague	Ring	Anillo	
	40	1611 70101	1	Albero forcelle cambio compl.	Driving shaft gearbox forks	Arbre comm. fourches trans.	Antriebswelle Schaltgabel	Eje mando horquilla cambio	
	41	1612 36502	1	Ingranaggio 2 ^a A.S. (Z=29)	Secondary shaft 2nd gear (Z=29)	Engrenage 2ème vitesse A.S. (Z=29)	Zah. f. 2. Geschw. Vorgelegew. (Z=29)	Engranaje 2° velocidad Eje S. (Z=29)	
	42	8000 63424	1	Ingranaggio 3 ^a A.S. (Z=26)	Secondary shaft 3rd gear (Z=26)	Engrenage 3ème vitesse A.S. (Z=26)	Zah. f. 3. Geschw. Vorgelegew. (Z=26)	Engranaje 3° velocidad Eje S. (Z=26)	
	43	1612 35701	1	Ingranaggio 6 ^a A.S. (Z=20)	Secondary shaft 6th gear (Z=20)	Engrenage 6ème vitesse A.S. (Z=20)	Zah. f. 6. Geschw. Vorgelegew. (Z=20)	Engranaje 6° velocidad Eje S. (Z=20)	
	44	1611 71501	1	Ingranaggio 5 ^a A.S. (Z=22)	Secondary shaft 5th gear (Z=22)	Engrenage 5ème vitesse A.S. (Z=22)	Zah. f. 5. Geschw. Vorgelegew. (Z=22)	Engranaje 5° velocidad Eje S. (Z=22)	
	45	8000 60463	1	Albero secondario	Layshaft	Arbre secondaire	Vorgelegewelle	Eje secundario	
	46	1612 38801	1	Ingranaggio 4 ^a A.S. (Z=24)	Secondary shaft 4th gear (Z=24)	Engrenage 4ème vitesse A.S. (Z=24)	Zah. f. 4. Geschw. (Z=24)	Engranaje 4° velocidad Eje S. (Z=24)	
	47	1513 71401	1	Rosetta	Washer	Rondelle	Scheibe	Arandela	
	48	1612 41501	1	Bussola	Bushing	Douille	Buchse	Manguito	
	49	1612 36101	1	Ingranaggio 1 ^a A.S. (Z=34)	Gear 1st speed (Z=34)	Engrenage 1ère (Z=34)	Zahnrad 1. Gang (Z=34)	Engranaje 1° velocidad (Z=34)	
	50	8000 93114	1	Coppia ingran. trasm. primaria	Set of matched primary	Engrenages trans. prim.	Stirnraderpaar	Copla engranaje trans. prim.	
	51	8000 36857	1	Rosetta di sicurezza	Washer	Rondelle	Scheibe	Arandela	
	52	8A00 38350	1	Rosetta	Washer	Rondelle	Scheibe	Arandela	
	53	8000 36856	1	Dado	Nut	Ecrou	Mutter	Tuerca	
	54	8000 69737	1	Albero primario completo	Main shaft	Arbre primaire	Hauptwelle	Eje principal completo	
	55	8000 60470	1	Albero secondario completo	Layshaft compl.	Arbre secondaire compl.	Vorgelegewelle kpl.	Eje secundario compl.	
	56	8000 63822	1	Bussola	Bushing	Douille	Buchse	Manguito	
	57	8000 83335	1	Campana frizione completo	Clutch housing compl.	Cage embrayage compl.	Kupplungskorb kpl.	Campana embrague compl.	
	61	8000 21535	6	Rosetta	Washer	Rondelle	Scheibe	Arandela	
	62	8H00 36022	1	Rosetta	Washer	Rondelle	Scheibe	Arandela	

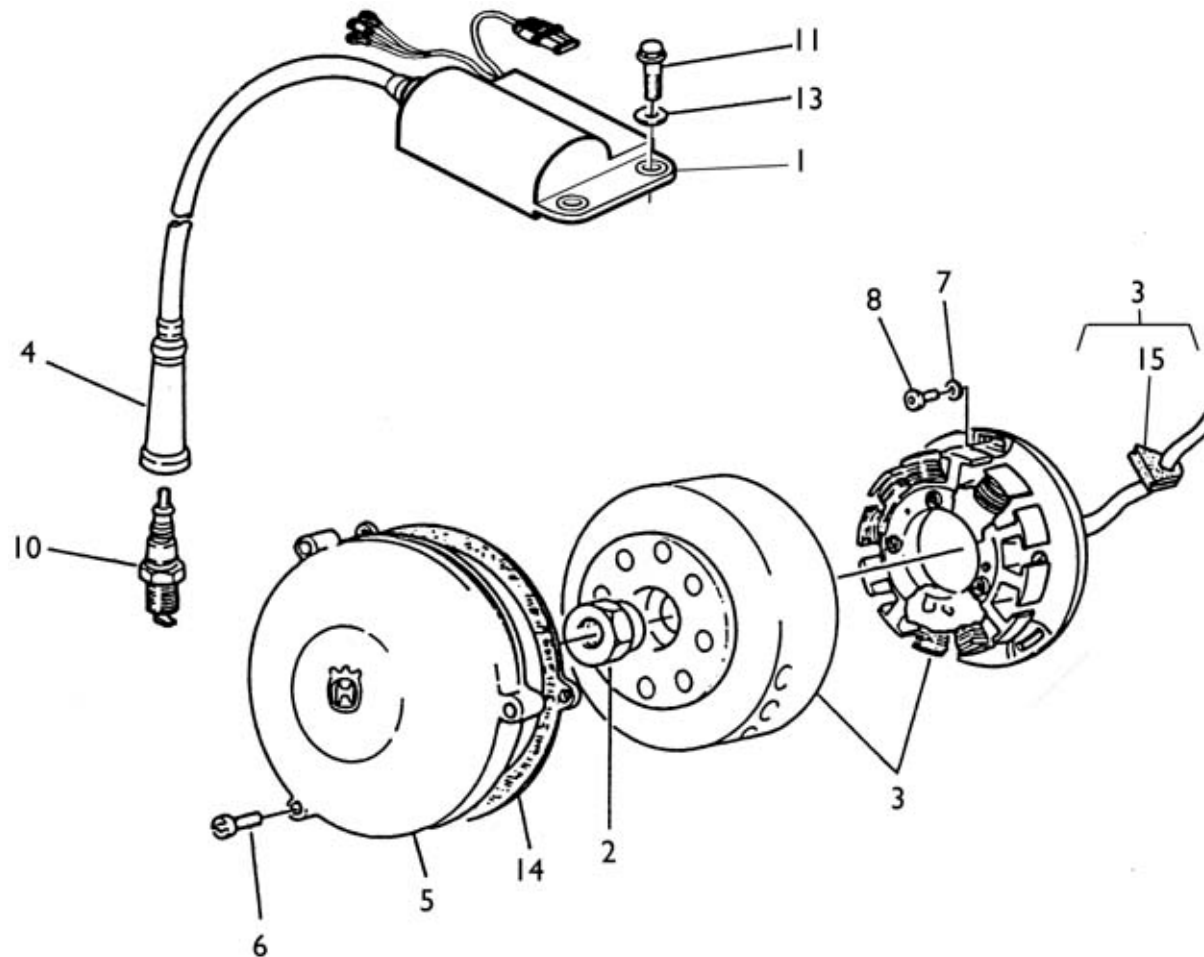

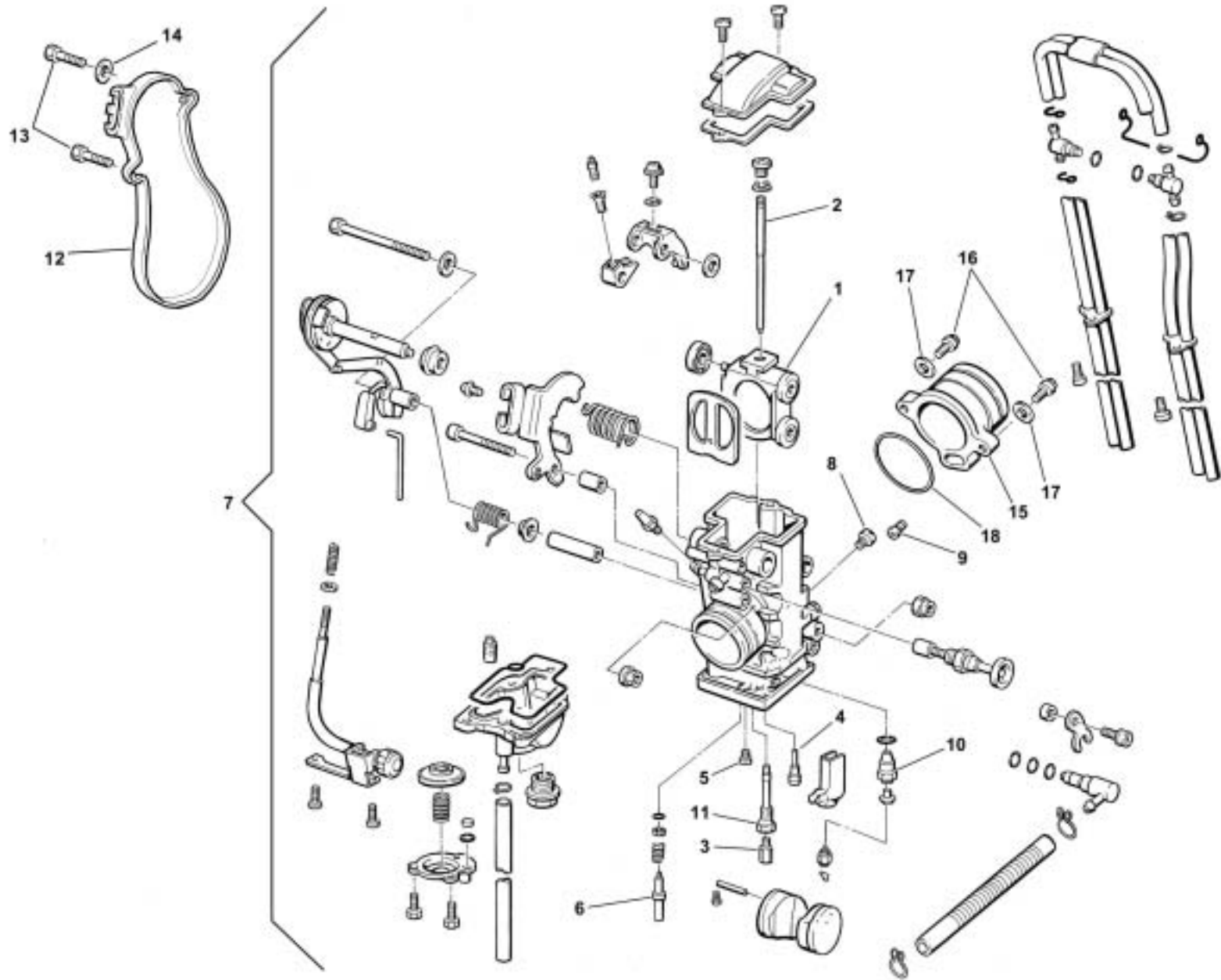



SMR 630 Seel replica

TAVOLA
DRAWING
TABLE
BILD
TABLA

10

CARBURATORE "KEIHIN"- CARBURETOR "KEIHIN" CARBURATEUR "KEIHIN"- VERGASER "KEIHIN" CARBURADOR "KEIHIN"

Note Notes Notes Marke Notas	Pos. No. N. Index Pos.	N. Cod. Code No. Nr. Code Code Nr N. Cod.	Q.tà Q.ty Q.te M.ge C.ad	DENOMINAZIONE	NAME	DESIGNATION	BESHREIBUNG	DENOMINACION	Validità Validity Validité Gültig Validez
	1	8000 98245	1	Valvola gas (15)	Throttle valve (15)	Papillon de gaz (15)	Drosselklappe (15)	Válvula (15)	
	2	8000 98196	1	Spillo conico (5a)	Needle (5th)	Pointeau conique (5éme)	Kon. Nadel (5.)	Pasador cónico (5°)	
	3	8A00 98186	1	Getto massimo (180)	Main jet (180)	Gicleur principal (180)	Hauptdüse (180)	Chiclé máximo (180)	
D	3	8000 98186	1	Getto massimo (185)	Main jet (185)	Gicleur principal (185)	Hauptdüse (185)	Chiclé máximo (185)	
D	3	8B00 98186	1	Getto massimo (190)	Main jet (190)	Gicleur principal (190)	Hauptdüse (190)	Chiclé máximo (190)	
	4	8000 A3738	1	Getto minimo (58)	Idle jet (58)	Gicleur minimum (58)	Leerlaufdüse (58)	Chiclé mínimo (58)	
D	4	8A00 98185	1	Getto minimo (50)	Idle jet (50)	Gicleur minimum (50)	Leerlaufdüse (50)	Chiclé mínimo (50)	
D	4	8000 98185	1	Getto minimo (52)	Idle jet (52)	Gicleur minimum (52)	Leerlaufdüse (52)	Chiclé mínimo (52)	
D	4	8B00 98185	1	Getto minimo (55)	Idle jet (55)	Gicleur minimum (55)	Leerlaufdüse (55)	Chiclé mínimo (55)	
	5	8000 98275	1	Getto starter (85)	Starter jet (85)	Gicleur starter (85)	Starterdüse (85)	Chiclé starter (85)	
	6	8000 98269	1	Vite minimo (1+1/4)	Idle screw (1+1/4)	Vis ralenti (1+1/4)	Leerlaufschraube (1+1/4)	Tornillo mínimo (1+1/4)	
	7	8000 98201	1	Carburatore completo	Carburetor assy	Carburateur complet	Vegaser, kpl.	Carburador compl.	
	8	8000 98250	1	Getto aria massimo (200)	Main air jet (200)	Gicleur aire max. (200)	Luftdüse Max. (200)	Chiclé aire máximo (200)	
	9	8000 98268	1	Getto aria minimo (100)	Idle air jet (100)	Gicleur aire min. (100)	Luftdüse Min. (100)	Chiclé aire mínimo (100)	
	10	8000 98272	1	Sede valvola a spillo (Ø3,8)	Needle seat (Ø3,8)	Siege pointeau conique (Ø3,8)	Konischnadelsitz (Ø3,8)	Alojamento pasador (Ø3,8)	
	11	8000 98276	1	Getto starter aria (210)	Starter air jet (210)	Gicleur starter aire (210)	Starterluftdüse (210)	Chiclé starter aire (210)	
	12	8000 98203	1	Protezione per carburatore	Carburetor guard	Protection pour carburateur	Vergaserschutz	Protección por carburador	
	13	8000 62727	2	Vite M6-L16	Screw M6-L16	Vis M6-L16	Schraube M6-L16	Tornillo M6-L16	
	14	8000 60969	1	Rosetta D12-d6,5-Sp3	Washer D12-d6,5-Th3	Rondelle D12-d6,5-èp.3	Scheibe D12-d6,5-S3	Arandela D12-d6,5-esp.3	
	15	8000 98207	1	Cornetto presa aria	Pipe	Manchon	Muffe	Tubo toma aire	
	16	60N1 02482	2	Vite	Screw	Vis	Schraube	Tornillo	
	17	8000 36137	2	Rosetta	Washer	Rondelle	Scheibe	Arandela	
	18	8000 98215	1	Anello OR	O-ring	Anneau O-ring	O-Ring	Anillo OR	

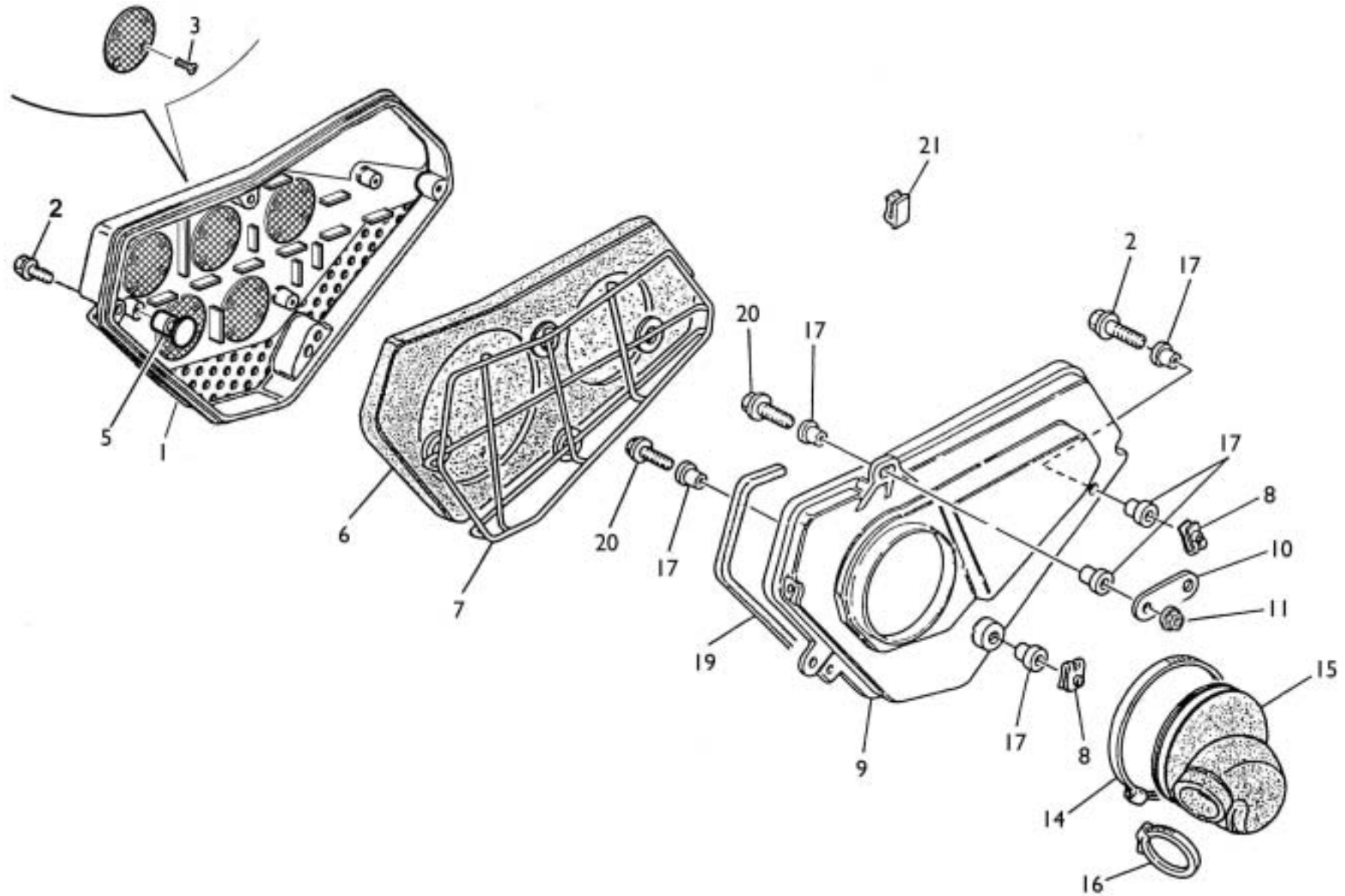



**SMR 630 Seel
replica**

TAVOLA
DRAWING
TABLE
BILD
TABLA

11

**FILTRO ARIA - AIR FILTER
FILTRE AIRE - LUFTFILTER
FILTRO DE AIRE**

Note Notes Marke Notas	Pos. No. N. Index Pos.	N. Cod. Code No. Nr. Code Code Nr N. Cod.	Q.tà Q.ty Q.te M.ge C.ad	DENOMINAZIONE	NAME	DESIGNATION	BESHREIBUNG	DENOMINACION	Validità Validity Validité Gültig Validez
A	1	8A00 98379	1	Coperchio	Cover	Couvercle	Deckel	Tapa	
	1	8000 98379	1	Coperchio	Cover	Couvercle	Deckel	Tapa	
	2	8000 62727	3	Vite (M6X16 mm)	Screw (M6X16 mm)	Vis (M6X16 mm)	Schraube (M6X16 mm)	Tornillo (M6X16 mm)	
	3	8B00 33690	20	Molletta di ritegno	Retaining spring	Ressorte de fixation	Feder	Resorte	
	5	8000 67970	4	Tampone	Pad	Tampon	Stopfen	Tampón	
D	6	8000 92948	1	Filtro aria	Air filter	Filtre à air	Luftfilter	Filtro aire	
	7	8000 92947	1	Gabbia filtro	Cleaner cage	Cage pour filtre	Filterkafig	Caja filtro	
	8	8000 46893	2	Dado a graffetta	Nut	Ecrou	Mutter	Tuerca	
	9	80A0 75671	1	Scatola filtro	Air filter box	Boîte filtre	Filterkasten	Caja filtro aire	
	10	1515 80301	1	Piastrina	Plate	Plaquette	Plättchen	Placa	
	11	8000 44240	1	Dado	Nut	Ecrou	Mutter	Tuerca	
	14	8F00 99475	1	Fascetta	Clamp	Collier	Schelle	Banda	
	15	8000 75672	1	Raccordo	Union	Raccord	Anschluss	Empalme	
	16	8E00 99475	1	Fascetta	Clamp	Collier	Schelle	Banda	
	17	8000 45495	6	Bussola	Bushing	Douille	Buchse	Manguito	
	19	8A00 60652	1	Guarnizione	Gasket	Garnitue	Dichtung	Junta	
	20	8000 62728	3	Vite (M6X20 mm)	Screw (M6X20 mm)	Vis (M6X20 mm)	Schraube (M6X20 mm)	Tornillo (M6X20 mm)	
	21	8000 56806	1	Gancio adesivo	Hook	Crochet	Haken	Gancho	

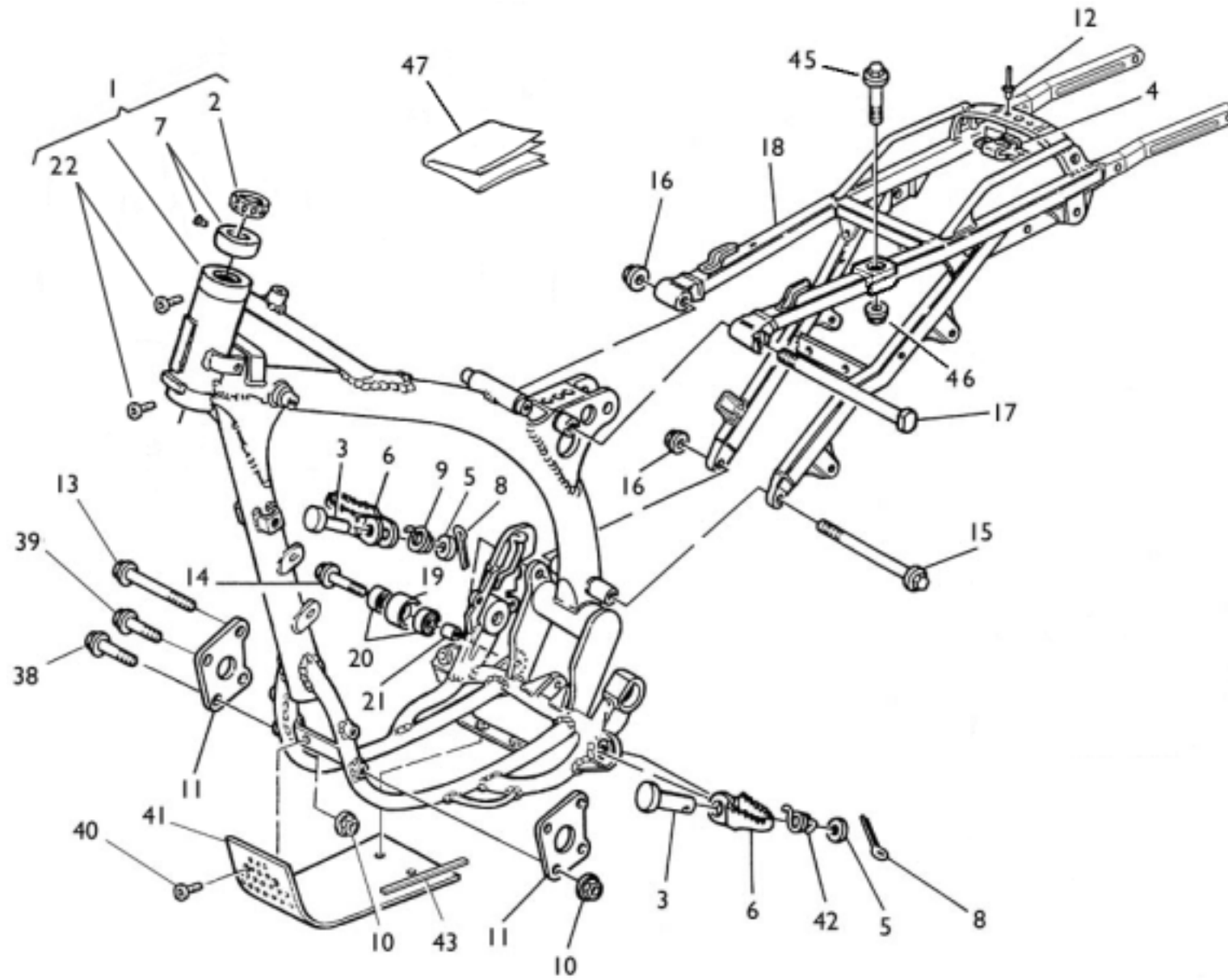



SMR 630 Seel
replica

TAVOLA
DRAWING
TABLE
BILD
TABLA

12

TELAIO, PEDANE - FRAME, FOOT RESTS
CADRE, REPOSE PIEDS - RAHMEN, FUSSRASTE
BASTIDOR, REPOSAPIES

Note Notes Notas	Pos. No. Index Pos.	N. Cod. Code No. Nr. Code Code Nr N. Cod.	Q.tà Q.ty Q.te M.ge C.ad	DENOMINAZIONE	NAME	DESIGNATION	BESHREIBUNG	DENOMINACION	Validità Validity Validité Gültig Validez
	1	8A00 A3634	1	Telaio	Frame	Chassis	Rahmen	Bastidor	
	2	8000 87243	2	Cuscinetto a rulli conici (ø25xø50x17,5 mm)	Bearing (ø25xø50x17,5 mm)	Roulement à roulewux coniq. (ø25xø50x17,5 mm)	Lager (ø25xø50x17,5 mm)	Cojinete de rodillos cónicos (ø25xø50x17,5 mm)	
	3	8000 73140	2	Perno	Pin	Pivot	Bolzen	Perno	
	4	8000 69150	1	Piastrina	Plate	Plaquette	Plättchen	Placa	
	5	8A00 01815	2	Rosetta	Washer	Rondelle	Scheibe	Arandela	
	6	8000 93156	2	Coppia poggiapiedi	Foot rest support pair	Couple support repose pied	Fussrasterpaar	Parejas prisioneros	
D	7	8A00 A3517	2	Boccola	Bush	Douille	Buchse	Manguito	
D	7	8B00 A3517	2	Boccola	Bush	Douille	Buchse	Manguito	
D	7	8C00 A3517	2	Boccola	Bush	Douille	Buchse	Manguito	
D	7	8D00 A3517	1	Boccola	Bush	Douille	Buchse	Manguito	
D	7	8E00 A3517	1	Boccola	Bush	Douille	Buchse	Manguito	
D	7	8F00 A3517	1	Boccola	Bush	Douille	Buchse	Manguito	
D	7	8G00 A3517	1	Boccola	Bush	Douille	Buchse	Manguito	
	8	64N1 20068	2	Copiglia	Split pin	Goupille	Splint	Clavija	
	9	8000 96908	1	Molla Dx	R.H. spring	Ressort D.	Feder Rechte	Resorte der.	
	10	80B0 43928	6	Dado	Nut	Ecrou	Mutter	Tuerca	
	11	8A00 84665	2	Piastra motore	Motor plate	Plaquette moteur	Motorplättchen	Placa motor	
	12	8000 33373	2	Rivetto	Rivet	Rivet	Niet	Remache	
	13	8000 80277	2	Vite (M8x95 mm)	Screw (M8x95 mm)	Vis (M8x95 mm)	Schraube (M8x95 mm)	Tornillo (M8x95 mm)	
	14	8000 62796	2	Vite (M8x40 mm)	Screw (M8x40 mm)	Vis (M8x40 mm)	Schraube (M8x40 mm)	Tornillo(M8x40 mm)	
	15	8C00 69112	1	Vite (M8x145 mm)	Screw (M8x145 mm)	Vis (M8x145 mm)	Schraube (M8x145 mm)	Tornillo (M8x145 mm)	
	16	8000 43928	2	Dado	Nut	Ecrou	Mutter	Tuerca	
	17	8000 69111	1	Vite (M8x130 mm)	Screw (M8x130 mm)	Vis (M8x130 mm)	Schraube (M8x130 mm)	Tornillo (M8x130 mm)	
	18	8000 A3540	1	Telaio posteriore	Rear frame side	Chassis arrière	Sattelbrücke	Cuadro posterior	
D	19	8000 59433	2	Rullo	Roller	Aiguille	Rolle	Rodillo	
D	20	8000 63312	4	Cuscinetto (ø8xø22x7 mm)	Bearing (ø8xø22x7 mm)	Roulement (ø8xø22x7 mm)	Lager (ø8xø22x7 mm)	Cojinete (ø8xø22x7 mm)	
D	21	8000 59434	2	Distanziale	Spacer	Entretoise	Distanzstück	Separador	
	22	60N1 02555	2	Vite (M8x20 mm)	Screw (M8x20 mm)	Vis (M8x20 mm)	Schraube (M8x20 mm)	Tornillo (M8x20 mm)	
	38	8E00 69056	2	Vite (M8x55 mm)	Screw (M8x55 mm)	Vis (M8x55 mm)	Schraube (M8x55 mm)	Tornillo (M8x55 mm)	
	39	8I00 69056	2	Vite (M8x60 mm)	Screw (M8x50 mm)	Vis (M8x50 mm)	Schraube (M8x50 mm)	Tornillo (M8x50 mm)	
	40	8000 60898	4	Vite	Screw	Vis	Schraube	Tornillo	
	41	8000 A3846	1	Paramotore	Engine guard	Garde moteur	Motorschutz	Para motor	

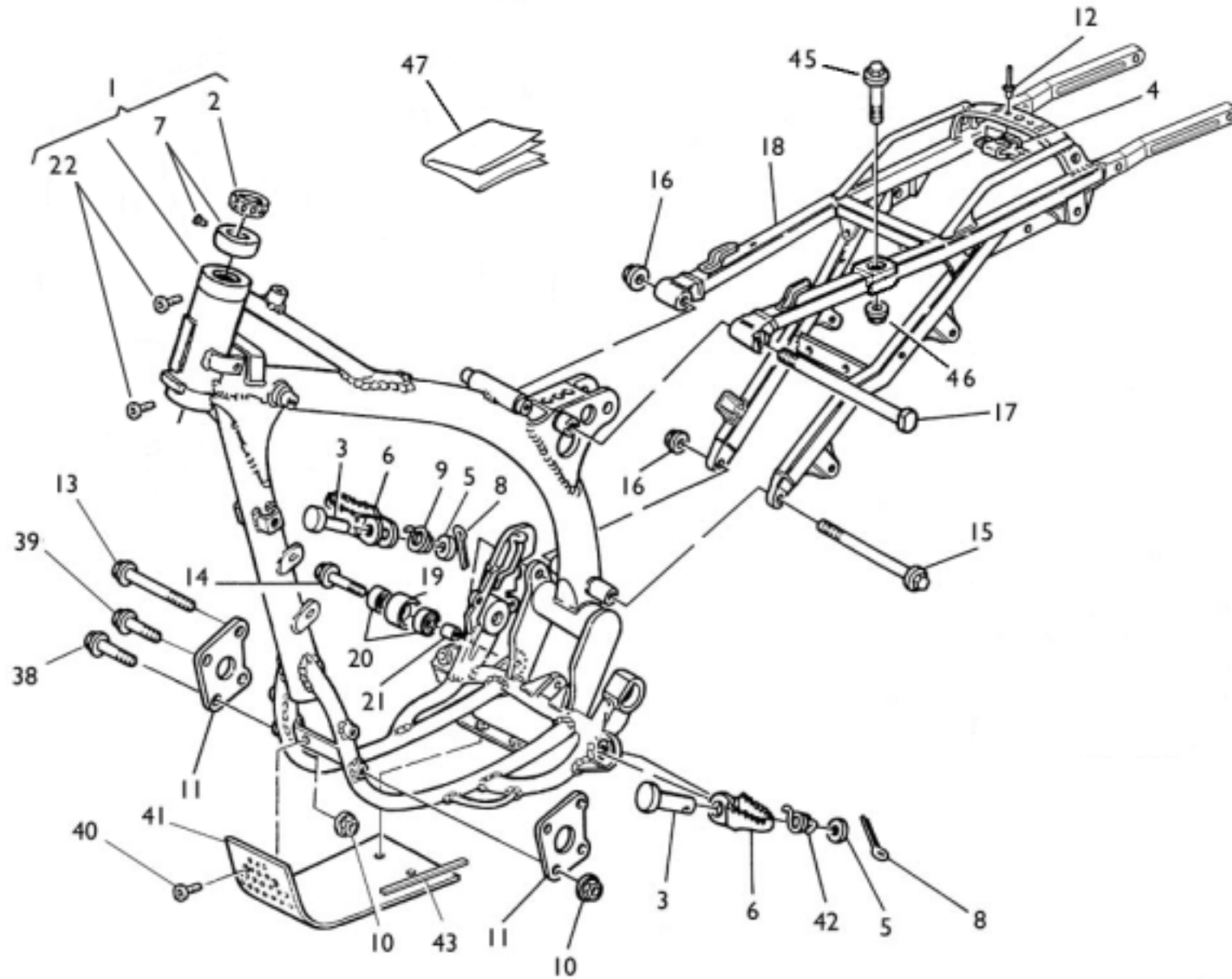

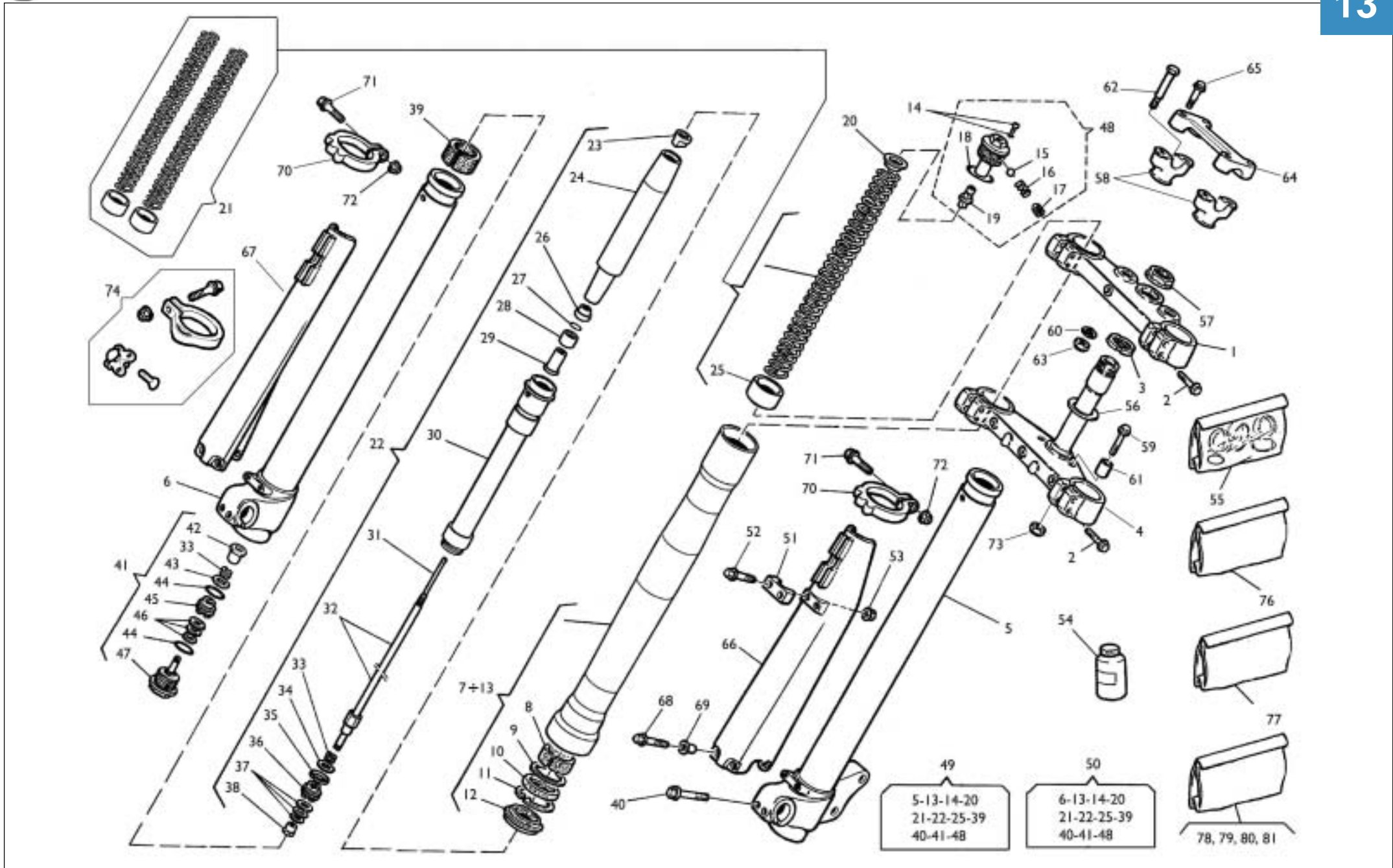



**SMR 630 Seel
replica**

TAVOLA
DRAWING
TABLE
BILD
TABLA

13

**SOSPENSIONE ANTERIORE - FRONT FORK ASSEMBLY
SUSPENSION AVANT - VORDERTELESKOPGABEL
SUSPENSION DELANTERA**

Note Notes Notas	Pos. No. Index Pos.	N. Cod. Code No. Nr. Code Code Nr N. Cod.	Q.tà Q.ty Q.te M.ge C.ad	DENOMINAZIONE	NAME	DESIGNATION	BESHREIBUNG	DENOMINACION	Validità Validity Validité Gültig Validez
	1	8000 A3662	1	Testa di sterzo	Steering head	Tête direction	Lenkkopf	Cabezal de dirección	
	2	8000 62796	8	Vite (M8x40 mm)	Screw (M8x40 mm)	Vis (M8x40 mm)	Schraube (M8x40 mm)	Tornillo (M8x40 mm)	
	3	8A00 87717	1	Ghiera registro cuscinetti	Ring nut	Embout	Nutmutter	Virol	
	4	8000 A3663	1	Base di sterzo con perno	Steering crown with pin	Socle de direction avec pivot	Gabelbrücke mit Bolzen	Base de dirección con perno	
	5	8000 A3670	1	Stelo Sx. compl.	L.H. slider assy	Montant G. compl.	Bein, Kpl. L.	Deslizable izrda. compl.	
	6	8000 A3667	1	Stelo Dx. compl.	R.H. slider assy	Montant D. compl.	Bein, Kpl. R.	Deslizable der. compl.	
	7	8000 A3671	1	Portastelo Sx completo	L.h. pipe assy	Groupe tuyau G. compl.	Linke Rohrgruppe Kpl	Grupo tubo izquierdo compl.	
N	8	(a), (b)	2	Bussola	Bushing	Douille	Buchse	Manguito	
N	9		2	Scodellino	Cup	Cuvette	Teller	Cubeta	
N	10	(a), (c)	2	Anello di tenuta	Seal ring	Bague de retenue	Dichtring	Anillo de retención	
N	11	(c)	2	Anello di fermo	Stop ring	Bague d'arrêt	Haltering	Anillo de retención	
N	12	(a), (c)	2	Raschiapolvere	Dust scraper	Racloir poudre	Pulverabschaber	Rascador de polvo	
	13	8000 A3668	1	Portastelo Dx completo	R.h. pipe assy	Groupe tuyau D. compl.	Rechte Rohrgruppe Kpl	Grupo tubo derecho compl.	
N	14		2	Vite	Screw	Vis	Schraube	Tornillo	
N	15		2	Sfera	Ball	Bille	Kugel	Esfera	
N	16		2	Molla per sfera	Spring	Ressort	Feder	Resorte	
N	17		2	Grano filettato	Dowel	Grain	Stift	Pasadòr	
N	18	(a)	2	Anello OR	O-Ring	Bague OR	O-Ring	Anillo OR	
	19	8000 91479	2	Gruppo registro	Adjuster set	Groupe réglage	Reglergruppe	Grupo regulaciòn	
	20	8000 77373	2	Scodellino	Cup	Cuvette	Teller	Cubeta	
	21	8000 A0387	1	Kit molla (k= 5 N/mm)	Spring (k= 5 N/mm)	Ressort (k= 5 N/mm)	Feder (k= 5 N/mm)	Resorte (k= 5 N/mm)	
D	21	8000 91610	1	Kit molla (k= 4,5 N/mm)	Spring (k= 4,5 N/mm)	Ressort (k= 4,5 N/mm)	Feder (k= 4,5 N/mm)	Resorte (k= 4,5 N/mm)	
	22	8000 A0385	2	Gruppo pompante compl.	Damping element compl.	Amortissement compl.	Schwingungsdämpfer Kpl.	Bombedora compl.	
N	23		2	Dado	Nut	Ecrou	Mutter	Tuerca	
N	24		2	Guidamolla	Spring guide	Guide ressort	Federführung	Guia resorte	
N	25		2	Tubetto	Pipe	Tuyau	Rohr	Tubo	
N	26		2	Dado	Nut	Ecrou	Mutter	Tuerca	
N	27		2	Anello SEEGER	SEEGER ring	Anneau SEEGER	SEEGER Ring	Anillo SEEGER	
N	28		2	Tampone di fondo	Pad	Tampon	Stopfen	Tampòn	
N	29		2	Distanziale	Spacer	Entretoise	Distanzstück	Separadòr	
N	30		2	Custodia	Housung	Cage	Korb	Custodia	
N	31		2	Asta interna	Internal rod	Barre	Stange	Varilla	
N	32		2	Ass. asta	Rod assy	Barre compl.	Stange Kpl	Grupo varilla	

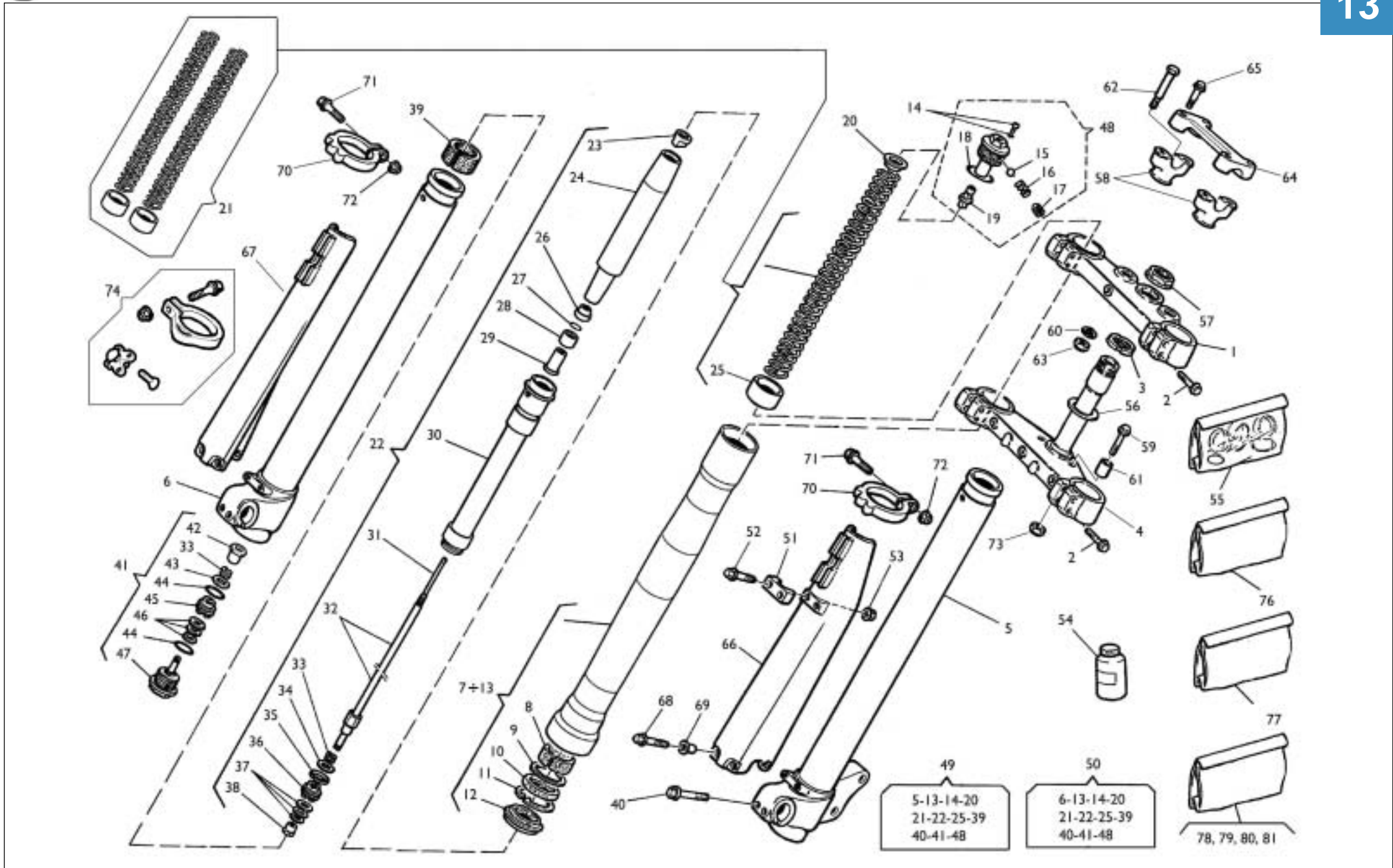



**SMR 630 Seel
replica**

TAVOLA
DRAWING
TABLE
BILD
TABLA

13

**SOSPENSIONE ANTERIORE - FRONT FORK ASSEMBLY
SUSPENSION AVANT - VORDERTELESKOPGABEL
SUSPENSION DELANTERA**

Note Notes Notas	Pos. No. Index Pos.	N. Cod. Code No. Nr. Code Code Nr N. Cod.	Q.tà Q.ty Q.te M.ge C.ad	DENOMINAZIONE	NAME	DESIGNATION	BESHREIBUNG	DENOMINACION	Validità Validity Validité Gültig Validez
N	33		4	Molla	Spring	Ressort	Feder	Resorte	
N	34	(d)	2	Lamella	Plate	Lamelle	Plättchen	Laminilla	
N	35	(a)	2	Segmento	Circlip	Segment	Colbenring	Segmento	
N	36		2	Pistone estensione	R.H. piston	Piston D.	Kolbe R.	Pistón der.	
N	37	(d)	6	Lamella	Plate	Lamelle	Plättchen	Laminilla	
N	38		2	Dado	Nut	Ecrou	Mutter	Tueca	
N	39	(a), (b)	2	Bussola	Bushing	Douille	Buchse	Manguito	
	40	8000 62729	4	Vite (M6x25 mm)	Screw (M6x25 mm)	Vis (M6x25 mm)	Schraube (M6x25 mm)	Tornillo (M6x25 mm)	
	41	8000 96647	2	Ass. valvola di fondo	Valve	Soupape	Ventil	Válvula	
N	42		2	Dado	Nut	Ecrou	Mutter	Tuerca	
N	43	(d)	2	Lamella	Plate	Lamelle	Plättchen	Laminilla	
N	44	(a)	2	Anello OR	O-Ring	Bague OR	O-Ring	Anillo OR	
N	45		2	Pistone compressione	Piston	Piston	Kolbe	Pistón	
N	46	(d)	6	Lamella	Plate	Lamelle	Plättchen	Laminilla	
N	47		2	Valvola	Valve	Soupape	Ventil	Valvula	
	48	8000 91480	2	Gruppo tappo	Plug assy	Groupe bouchon	Verschlussgruppe Kpl	Grupo tapón	
	49	8000 A3669	1	Gamba Sx. compl.	L.H. fork leg assy	Fourche complete G.	Telegabel Kpl. L.	Horquilla izrda. compl.	
	50	8000 A3666	1	Gamba Dx. compl.	R.H. fork leg assy	Fourche complete D.	Telegabel Kpl. R.	Horquilla derech. compl.	
	51	8000 A0633	1	Piastrina	Plate	Plaque	Plättchen	Placa	
	52	8A00 67997	2	Vite M5x1 L15	Screw M5x1 L15	Vis M5x1 L15	Schraube M5x1 L15	Tornillo M5x1 L15	
	53	8000 61355	2	Dado	Nut	Ecrou	Mutter	Tueca	
D	55	8000 A0379	1	Gruppo guarnizioni	Gasket set	Groupe garnitures	Dichtungssatz	Grupo juntas	
	56	8A00 65503	2	Rosetta piana	Washer	Rondelle	Scheibe	Arandela	
	57	8000 69315	1	Dado	Nut	Ecrou	Mutter	Tuerca	
	58	8000 A3840	2	Mozzetto inferiore	Hub	Moyeau	Radnabe	Cbo	
	59	8C00 28327	2	Vite (M6xL35)	Screw (M6xL35)	Vis (M6xL35)	Schraube (M6xL35)	Tornillo (M6xL35)	
	60	8000 36091	2	Rosetta piana	Washer	Rondelle	Scheibe	Arandela	
	61	8000 A3765	2	Distanziale	Spacer	Entretoise	Distanzstück	Separador	
	62	60N1 02594	2	Vite (M10x80 mm)	Screw(M10x80 mm)	Vis(M10x80 mm)	Schraube(M10x80 mm)	Tornillo(M10x80 mm)	
	63	8000 61314	2	Dado	Nut	Ecrou	Mutter	Tuerca	
	64	8000 A3573	1	Mozzetto superiore	Hub	Moyeau	Radnabe	Cubo	
	65	60N1 02555	4	Vite (M8x20 mm)	Screw (M8x20 mm)	Vis (M8x20 mm)	Schraube (M8x20 mm)	Tornillo (M8x20 mm)	
	66	8AA0 95696	1	Protezione steli Sx.	Guard L.H.	Protection D.	Schutz L.	Protección izq.	

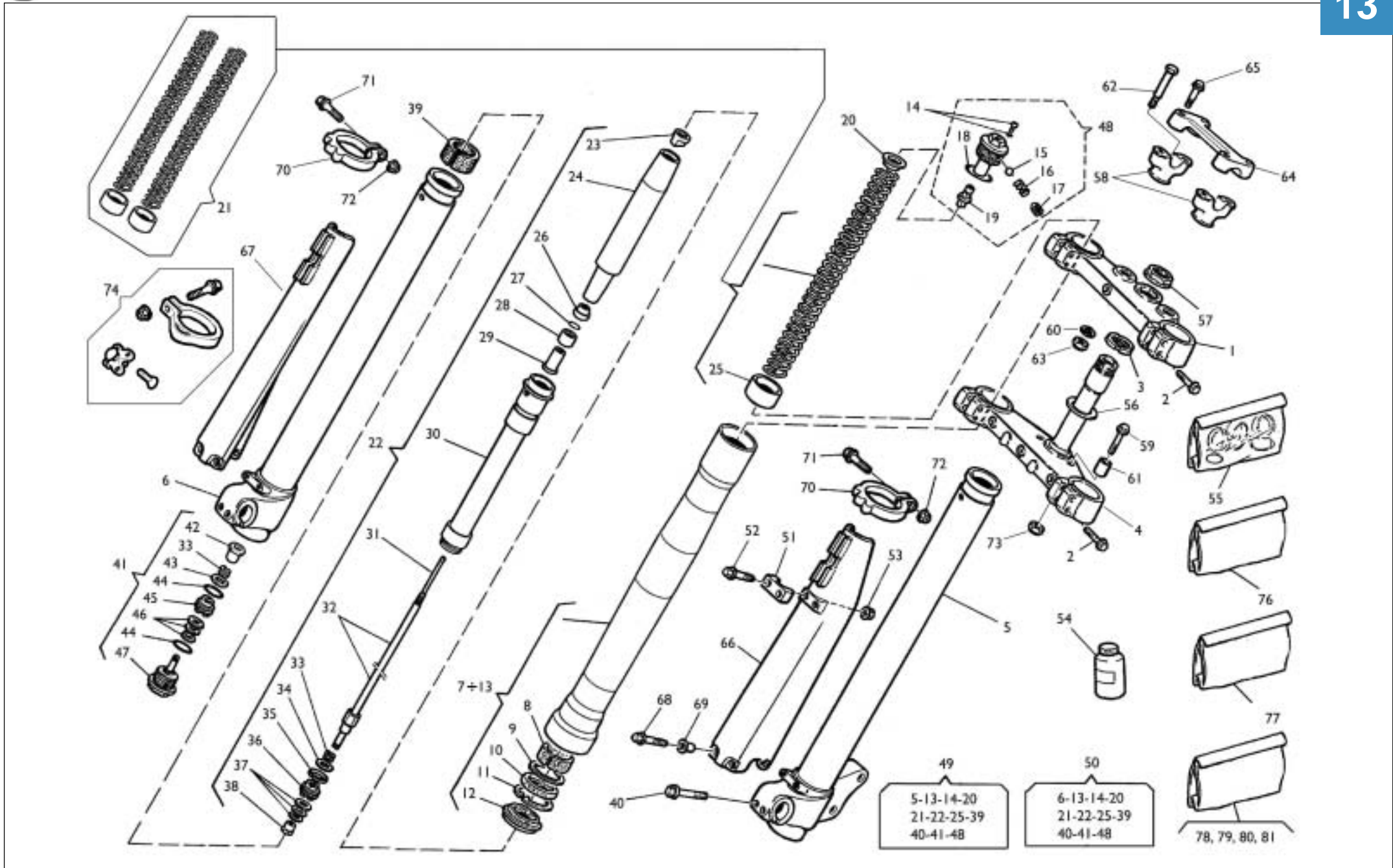



**SMR 630 Seel
replica**

TAVOLA
DRAWING
TABLE
BILD
TABLA

13

**SOSPENSIONE ANTERIORE - FRONT FORK ASSEMBLY
SUSPENSION AVANT - VORDETELESKOPGABEL
SUSPENSION DELANTERA**

Note Notes Notas	Pos. No. Index Pos.	N. Cod. Code No. Nr. Code Code Nr N. Cod.	Q.tà Q.ty Q.te M.ge C.ad	DENOMINAZIONE	NAME	DESIGNATION	BESHREIBUNG	DENOMINACION	Validità Validity Validité Gültig Validez
	67	8AG0 69338	1	Protezione steli Dx.	Guard R.H.	Protection G.	Schutz R.	Protección der.	
	68	8000 67997	6	Vite	Screw	Vis	Schraube	Tornillo	
	69	8000 69282	6	Bussola	Bush	Douille	Buchse	Manguito	
	70	8000 93283	2	Anello	Ring	Bague	Ring	Anilo	
	71	8B00 66525	2	Vite	Screw	Vis	Schraube	Tornillo	
	72	8000 56443	2	Dado	Nut	Ecrou	Mutter	Tuerca	
	73	8000 44240	2	Dado	Nut	Ecrou	Mutter	Tuerca	
D	74	8000 A3191	1	Kit gancio partenza	Starting hook kit	Kit crochet pour départ	Abfahrthacken	Gancho por salida	
	76	8000 A0381	1	Kit boccole	Bush kit	Kit douille	Buchsekit	Kit manguito	
	77	8000 97749	1	Kit anelli di tenuta	Seal ring kit	Kit bague de retenue	Dichtringkit	Kit anillo de retención	
	78	8000 98782	1	Kit lamelle (0,1 mm)	Plate kit (0,1 mm)	Kit lamelle (0,1 mm)	Plättchenkit (0,1 mm)	Kit Laminilla (0,1 mm)	
	79	8000 98783	1	Kit lamelle (0,2 mm)	Plate kit (0,2 mm)	Kit lamelle (0,2 mm)	Plättchenkit (0,2 mm)	Kit Laminilla (0,2 mm)	
	80	8000 98784	1	Kit lamelle (0,3 mm)	Plate kit (0,3 mm)	Kit lamelle (0,3 mm)	Plättchenkit (0,3 mm)	Kit Laminilla (0,3 mm)	
	81	8000 98785	1	Kit lamelle (0,4 mm)	Plate kit (0,4 mm)	Kit lamelle (0,4 mm)	Plättchenkit (0,4 mm)	Kit Laminilla (0,4 mm)	
a				Forniti in gruppo pos.55	Supplied in bag ref. N° 55	Son fournies en unités pos. 55	Sind im Umschlag Bez. Nr 55	Provisto en grupo pos. 55	
b				Forniti in gruppo pos.76	Supplied in bag ref. N° 76	Son fournies en unités pos. 76	Sind im Umschlag Bez. Nr 76	Provisto en grupo pos. 76	
c				Forniti in gruppo pos.77	Supplied in bag ref. N° 77	Son fournies en unités pos. 77	Sind im Umschlag Bez. Nr 77	Provisto en grupo pos. 77	
d				Forniti in gruppo pos. 78, 79, 80, 81	Supplied in bag ref. N° 78, 79, 80, 81	Son fournies en unités pos. 78, 79, 80, 81	Sind im Umschlag Bez. Nr 78, 79, 80, 81	Provisto en grupo pos. 78, 79, 80, 81	

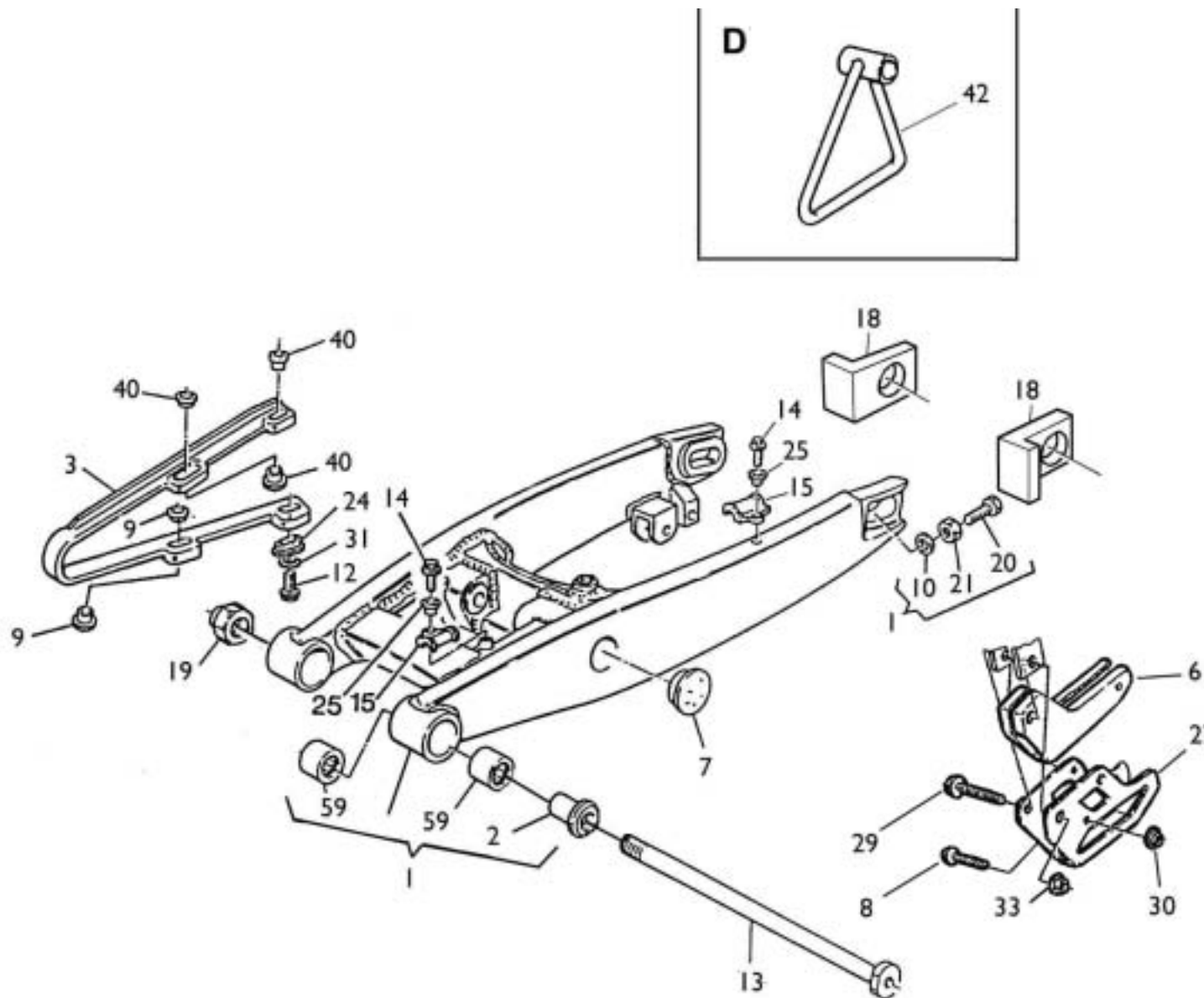



**SMR 630 Seel
replica**

TAVOLA
DRAWING
TABLE
BILD
TABLA

14

**FORCELLONE - SWING ARM
FOURCHE - GABEL
HORQUILLA**

Note Notes Notes Marke Notas	Pos. No. N. Index Pos.	N. Cod. Code No. Nr. Code Code Nr N. Cod.	Q.tà Q.ty Q.te M.ge C.ad	DENOMINAZIONE	NAME	DESIGNATION	BESHREIBUNG	DENOMINACION	Validità Validity Validité Gültig Validez
	1	8000 A3673	1	Forcellone completo	Compl. fork	Fourche complete	Gabel, Kpl.	Horquilla compl.	
	2	8A00 83904	2	Bussola	Bushing	Douille	Buchse	Manguito	
D	3	8000 72884	1	Pattino catena	Chain slider	Glissière	Gleitbahn	Plato cadena	
	6	8000 72868	1	Guidacatena	Chain guide	Guide-chaine	Kettenführung	Guía-cadena	
	7	80A0 74388	2	Tappo	Plug	Bouchon	Verschluss	Tapón	
	8	8000 62795	1	Vite	Screw	Vis	Schraube	Tornillo	
	9	8000 75166	4	Scodellino	Cup	Cuvette	Teller	Cubeta	
	10	8000 08536	2	Rosetta	Washer	Rondelle	Scheibe	Arandela	
	12	8000 67997	4	Vite	Screw	Vis	Schraube	Tornillo	
	13	8000 71620	1	Perno forcellone	Fork pin	Pivot fourche	Gabelbolzen	Perno horquilla	
	14	8000 20536	2	Vite	Screw	Vis	Schraube	Tornillo	
	15	80A0 73456	2	Guidacavo	Cable guide	Guide câble	Kabelführung	Guía-cable	
	18	8000 96944	1	Tendicatena lato dado	Chain adjuster - nut side	Tendeur de chaine côtés ecrou	Kettenspanner Mutterseite	Tensor de cadena lato tuerca	
	18	8000 96941	1	Tendicatena lato perno	Chain adjuster - pin side	Tendeur de chaine côtés pivot	Kettenspanner bolzenseite	Tensor de cadena lato perno	
	19	8000 71623	1	Dado	Nut	Ecrou	Mutter	Tuerca	
	20	8C00 61121	2	Vite	Screw	Vis	Schraube	Tornillo	
	21	8000 17810	2	Dado	Nut	Ecrou	Mutter	Tuerca	
	24	8000 59289	2	Scodellino	Cup	Cuvette	Teller	Cubeta	
	25	8000 69282	2	Bussola	Bushing	Douille	Buchse	Manguito	
	27	8A00 72869	1	Staffa per guidacatena	Chain guide bracket	Etrier pour guide chaine	Kettenführungbuegel	Brida por guia cadena	
	29	8C00 62731	1	Vite	Screw	Vis	Schraube	Tornillo	
	30	8000 43928	1	Dado	Nut	Ecrou	Mutter	Tuerca	
	31	8000 36137	4	Rosetta	Washer	Rondelle	Scheibe	Arandela	
	33	8000 44240	1	Dado	Nut	Ecrou	Mutter	Tuerca	
D	42	8000 74016	1	Gamba laterale	Side stand	Bequille lat.	Seitenständer	Horquilla lateral	
	59	8000 76283	4	Gabbia a rulli	Needle cage	Cage à aiguilles	Nadelkäfig	Jaula de agujas del cojinete	

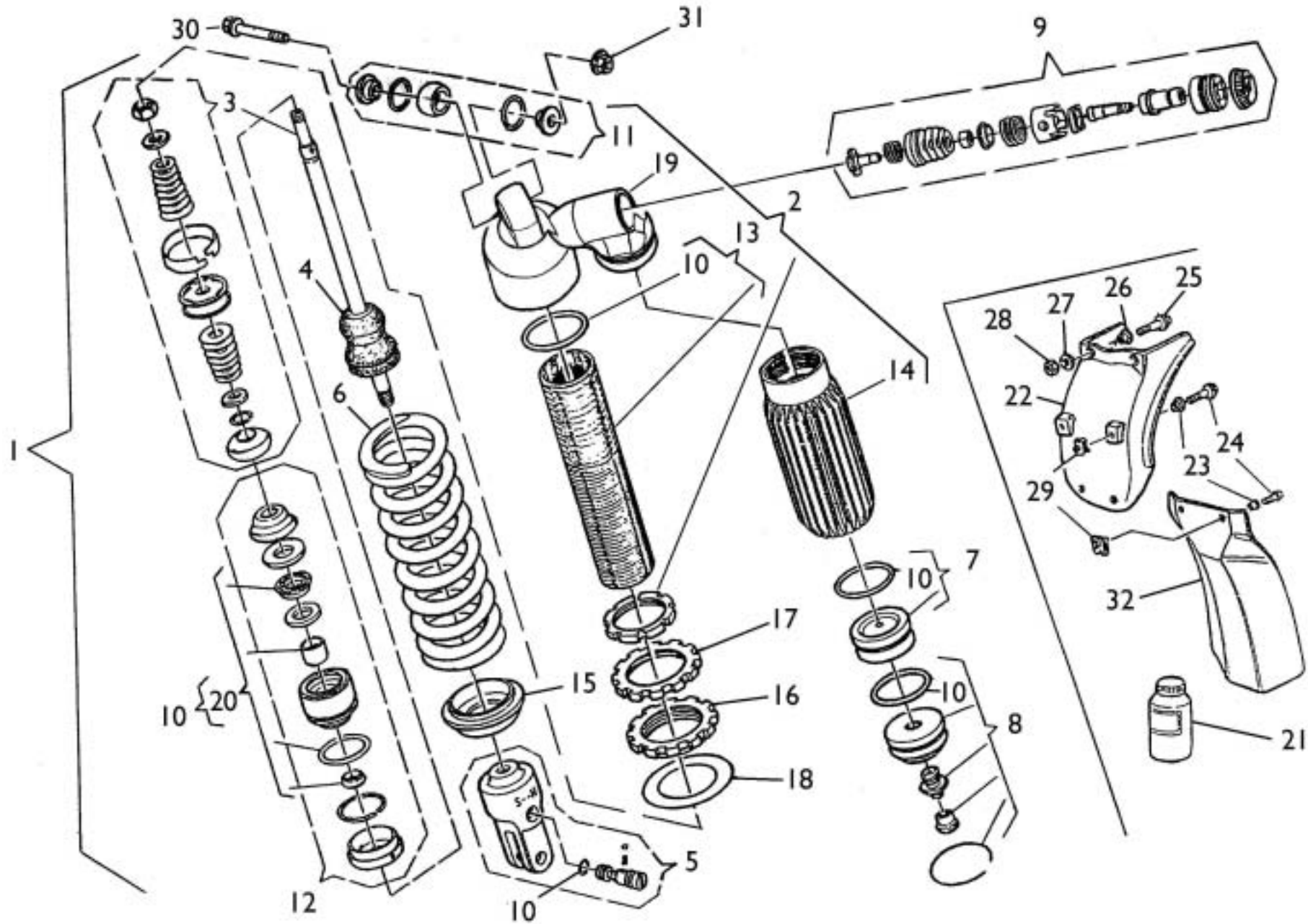



**SMR 630 Seel
replica**

TAVOLA
DRAWING
TABLE
BILD
TABLA

15

**AMMORTIZZATORE POSTERIORE- REAR SUSPENSION
SUSPENSION ARRIERE- HINTERHAUFHANGUNG
SUSPENSION TRASERA**

Note Notes Notas	Pos. No. N. Index Pos.	N. Cod. Code No. Nr. Code Code Nr N. Cod.	Q.tà Q.ty Q.te M.ge C.ad	DENOMINAZIONE	NAME	DESIGNATION	BESHREIBUNG	DENOMINACION	Validità Validity Validité Gültig Validez
	1	8000 97590	1	Ammortizzatore completo	Shock-absorber	Ammortisseur	Stossdämpfer	Amortigüador	
	2	8000 98512	1	Gruppo corpo	Damper case assy	Groupe corps amortisseur	Stossdämpferkörper Kpl.	Corpo amortigüador compl.	
	3	8000 98519	1	Gruppo stelo	Rod assy	Groupe tige	Pumpenstückgruppe	Grupo espiga	
	4	8000 91238	1	Tampone	Pad	Tampon	Stopfen	Tampòn	
	5	8000 98489	1	Gruppo forcella	Fork assy	Groupe fourche	Gabelgruppe Kpl.	Grupo horquilla	
D	6	8000 98548	1	Molla (k=6,0 Kg/mm)	Spring (k=6,0 Kg/mm)	Ressort (k=6,0 Kg/mm)	Feder (k=6,0 Kg/mm)	Resorte (k=6,0 Kg/mm)	
	6	8000 98520	1	Molla (k=6,4 Kg/mm)	Spring (k=6,4 Kg/mm)	Ressort (k=6,4 Kg/mm)	Feder (k=6,4 Kg/mm)	Resorte (k=6,4 Kg/mm)	
	7	8000 98490	1	Diaframma	Diaphragm	Diaphragme	Biegeplatte	Diafragma	
	8	8000 98491	1	Gruppo serbatoio	Tank assy	Groupe reservoir	Tankgruppe Kpl.	Grupo deposito compl.	
	9	8000 98492	1	Gruppo regolazione	Adjuster set	Groupe réglage	Reglergruppe Kpl.	Grupo regulacion	
	10	8000 98493	1	Gruppo guarnizioni	Gasket set	Groupe garnitures	Dichtungssatz	Grupo juntas	
	11	8000 89089	1	Gruppo snodo	Ball joint assy	Groupe joint a rotule	Kugelgelenkgruppe Kpl.	Grupo articulaciòn esferica	
	12	8000 98494	1	Gruppo guida stelo	Guide rod assy	Groupe guide tige	Pumpenstückführunggruppe	Grupo guja espiga	
	13	8000 98514	1	Corpo ammortizzatore	Damper case	Corps amortisseur	Stossdämpferkörper	Corpo amortigüador	
	14	8000 98515	1	Serbatoio	Tank	Reservoir	Tank	Deposito	
	15	8000 98496	1	Fondello	Bottom	Fond	Bodenscheibe	Casquilo	
	16	8000 98497	1	Ghiera	Ring nut	Embout	Nutmutter	Virola	
	17	8000 98498	1	Ghiera	Ring nut	Embout	Nutmutter	Virola	
	18	8000 98499	1	Rosetta per molla	Washer	Rondelle	Scheibe	Arandela	
	19	8000 98517	1	Supporto serbatoio	Tank holder	Support pour réservoir	Tankhalter	Soporte por deposito	
	20	8000 98495	1	Gruppo guarnizioni per stelo	Rod gasket set	Jeu joints pour tige	Dichtungs für Pumpenstock	Serie juntas por espiga	
	22	8000 92961	1	Protezione ammortizzatore	Guard	Protection	Schutz	Protección	
	23	8000 69429	4	Bussola	Bushing	Douille	Buchse	Manguito	
	24	8000 62727	4	Vite	Screw	Vis	Schraube	Tornillo	
	25	8A00 67545	2	Vite	Screw	Vis	Schraube	Tornillo	
	26	8000 72268	2	Distanziale	Spacer	Entretoise	Distanzstück	Separador	
	27	8000 56359	2	Rosetta piana	Washer	Rondelle	Scheibe	Arandela	
	28	8000 44240	2	Dado	Nut	Ecrou	Mutter	Tuerca	
	29	8000 46893	4	Dado a graffetta	Nut	Ecrou	Mutter	Tuerca	
	30	8D00 62797	1	Vite (M10x47 mm)	Screw (M10x47 mm)	Vis (M10x47 mm)	Schraube (M10x47 mm)	Tornillo (M10x47 mm)	
	31	8000 42022	1	Dado	Nut	Ecrou	Mutter	Tuerca	
	32	80A0 69551	1	Protezione ammortizzatore	Guard	Protection	Schutz	Protección	

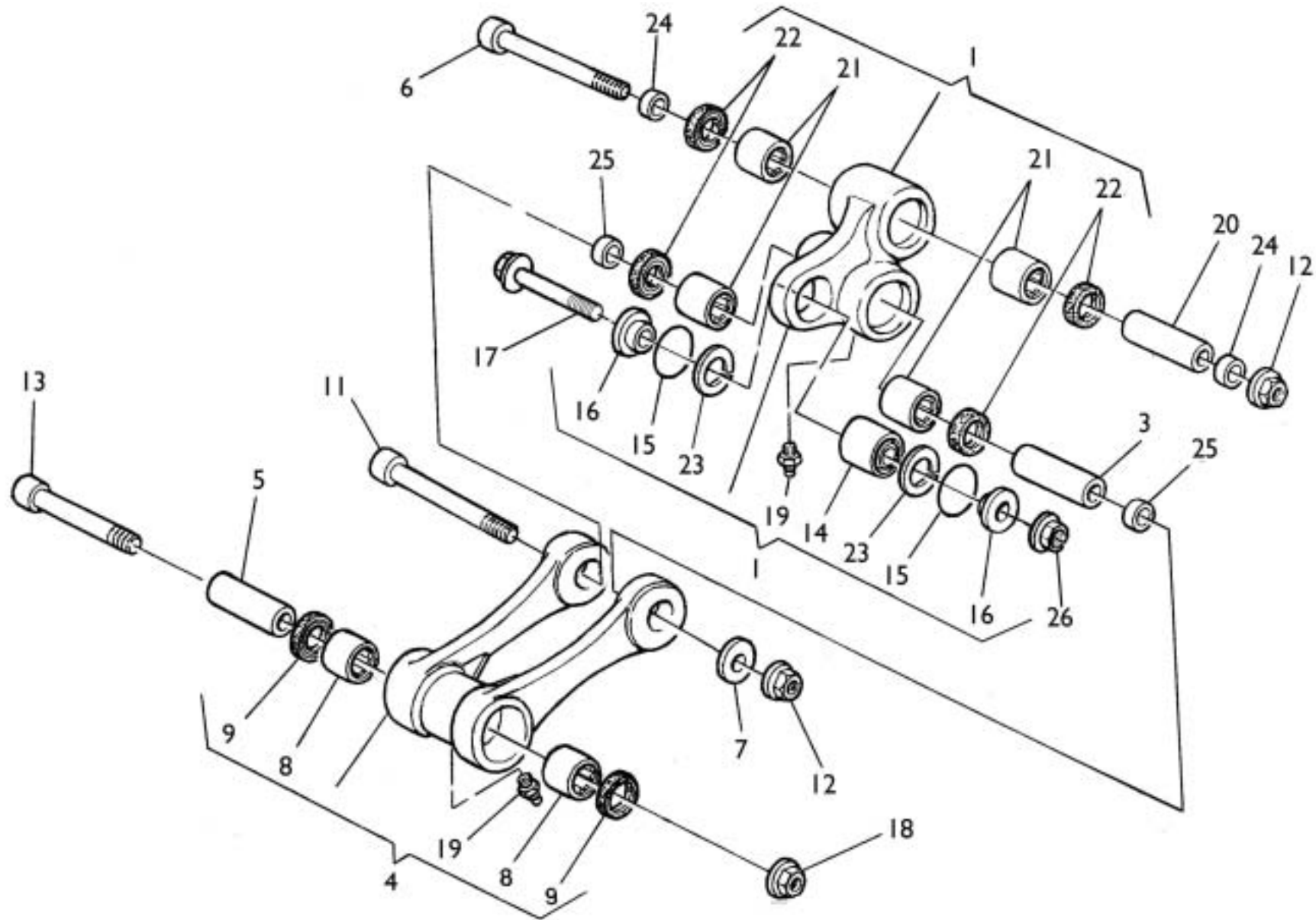



**SMR 630 Seel
replica**

TAVOLA
DRAWING
TABLE
BILD
TABLA

16

**LEVERAGGI SOSPENSIONE POST. - REAR SUSPENSION LINKAGE
LEVIER SUSPENSION ARRIERE - HEBELWERK HINTERHAUFHANGUNG
PALANCA SUSPENSION TRASERA**

Note Notes Notas	Pos. No. Index Pos.	N. Cod. Code No. Nr. Code Code Nr N. Cod.	Q.tà Q.ty Q.te M.ge C.ad	DENOMINAZIONE	NAME	DESIGNATION	BESHREIBUNG	DENOMINACION	Validità Validity Validité Gültig Validez
	1	8000 97052	1	Assieme bilanciata	Rocking lever assy	Balancier compl.	Schwinge Kpl.	Balancines compl.	
	3	8000 86176	1	Spinotto	Gudgeon	Axe	Bolzen	Perno	
	4	8000 97054	1	Tirante completo	Tie rod	Tirant	Spannstange	Tirante	
	5	8000 97050	1	Spinotto	Gudgeon	Axe	Bolzen	Perno	
	6	8E00 86138	1	Vite (M12x100 mm)	Screw (M12x100 mm)	Vis (M12x100 mm)	Schraube (M12x100 mm)	Tornillo (M12x100 mm)	
	7	8000 86140	1	Rosetta	Washer	Rondelle	Scheibe	Arandela	
	8	8000 86136	2	Cuscinetto (ø22xø28x16 mm)	Bearing (ø22xø28x16 mm)	Roulement (ø22xø28x16 mm)	Lager (ø22xø28x16 mm)	Cojinete (ø22xø28x16 mm)	
	9	8000 38521	2	Anello di tenuta (ø22xø28x4 mm)	Seal ring (ø22xø28x4 mm)	Bague de retenue (ø22xø28x4 mm)	Dichtring (ø22xø28x4 mm)	Anillo de retención (ø22xø28x4 mm)	
	11	8000 93124	1	Vite (M12x103 mm)	Screw (M12x103 mm)	Vis (M12x103 mm)	Schraube (M12x103 mm)	Tornillo (M12x103 mm)	
	12	8000 42023	2	Dado	Nut	Ecrou	Mutter	Tuerca	
	13	8B00 86138	1	Vite (M12x121 mm)	Screw (M12x121 mm)	Vis (M12x121 mm)	Schraube (M12x121 mm)	Tornillo (M12x121 mm)	
	14	8000 72168	1	Cuscinetto sferico (ø12xø26x16 mm)	Bearing (ø12xø26x16 mm)	Roulement (ø12xø26x16 mm)	Lager (ø12xø26x16 mm)	Cojinete (ø12xø26x16 mm)	
	15	8000 38767	2	Anello OR	O-Ring	Bague OR	O-Ring	Anillo OR	
	16	1511 33302	2	Bussola	Bushing	Douille	Buchse	Manguito	
	17	8D00 62797	1	Vite (M10x47 mm)	Screw (M10x47 mm)	Vis (M10x47 mm)	Schraube (M10x47 mm)	Tornillo (M10x47 mm)	
	18	8000 42023	1	Dado	Nut	Ecrou	Mutter	Tuerca	
	19	8000 01412	2	Ingrassatore	Lubricator	Graisser	Schmierbüchse	Lubricador	
	20	8D00 86176	1	Spinotto	Gudgeon	Axe	Bolzen	Perno	
	21	8000 86136	4	Cuscinetto (ø22xø28x16 mm)	Bearing (ø22xø28x16 mm)	Roulement (ø22xø28x16 mm)	Lager (ø22xø28x16 mm)	Cojinete (ø22xø28x16 mm)	
	22	8000 86137	4	Anello di tenuta (ø26xø34x4 mm)	Seal ring (ø26xø34x4 mm)	Bague de retenue (ø26xø34x4 mm)	Dichtring (ø26xø34x4 mm)	Anillo de retención (ø26xø34x4 mm)	
	23	8000 90561	2	Anello elastico	Split ring	Anneau ressort	Sprengring	Anillo elástico	
	24	8A00 86177	2	Distanziale	Spacer	Entretoise	Distanzstück	Separador	
	25	8000 86177	2	Distanziale	Spacer	Entretoise	Distanzstück	Separador	
	26	8000 42022	1	Dado	Nut	Ecrou	Mutter	Tuerca	

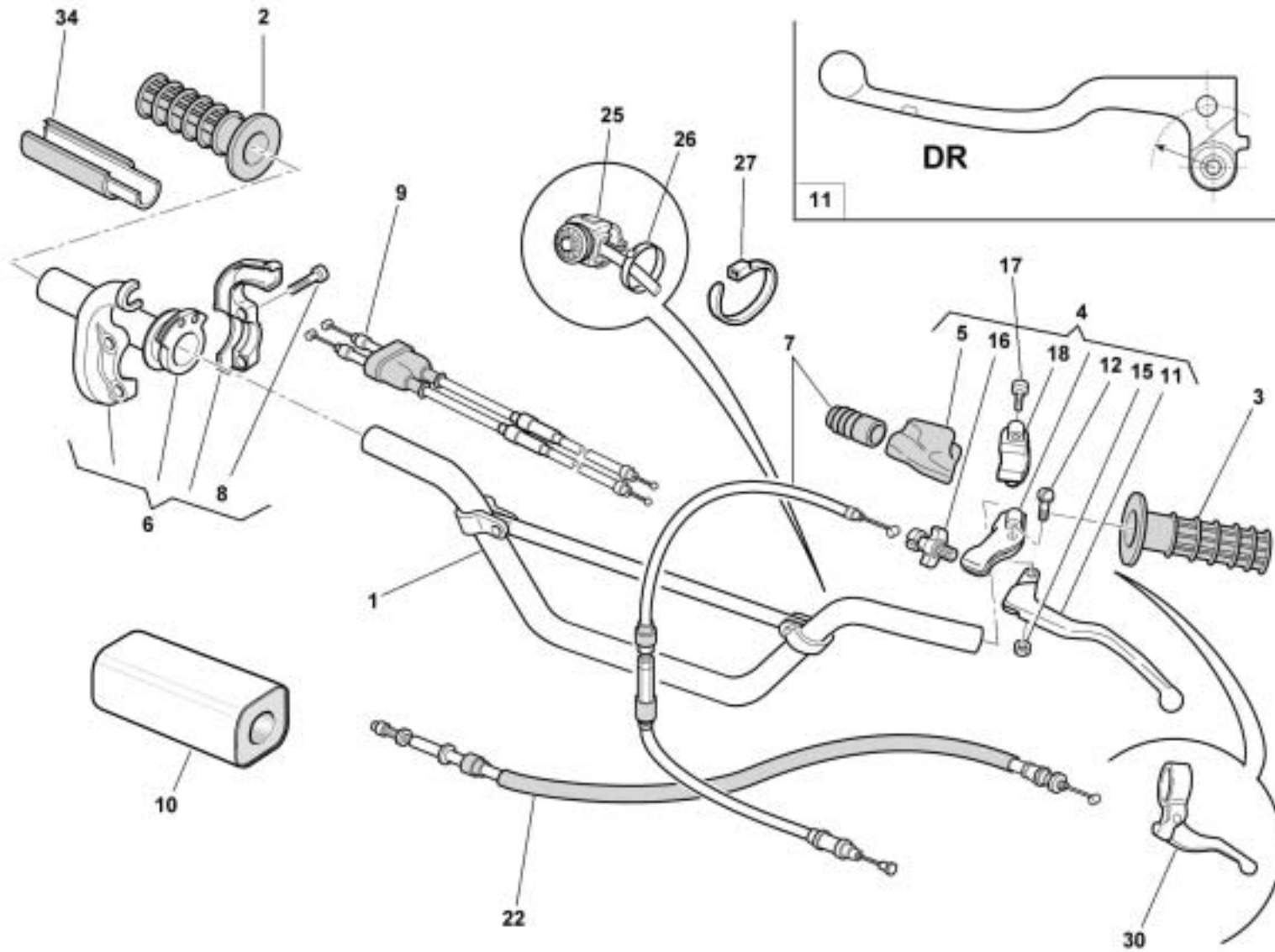



SMR 630 Seel replica

TAVOLA
DRAWING
TABLE
BILD
TABLA

17

**MANUBRIO E COMANDI - HANDLEBAR AND CONTROLS
GUIDON ET COMMANDES - LENKER UND STEUERORGANE
MANILLAR Y MANDOS**

Note Notes Marken Notas	Pos. No. Index Pos.	N. Cod. Code No. Nr. Code Code Nr N. Cod.	Q.tà Q.ty Q.te M.ge C.ad	DENOMINAZIONE	NAME	DESIGNATION	BESHREIBUNG	DENOMINACION	Validità Validity Validité Gültig Validez
	1	80A0 A3612	1	Manubrio	Handlebar	Guidon	Lenker	Manillar	
	2	8000 76688	1	Manopola Dx.	R.H. grip	Poignée G.	Griff R.	Manopla der.	
	3	8000 76687	1	Manopola Sx.	L.H. grip	Poignée G.	L. Griff	Manopla izdrda.	
	4	8BA0 75330	1	Comando frizione compl.	Clutch control lever, assy	Levier com. embrayage compl.	Kupplungshebel, Kpl.	Palanca embrague comp.	
	5	8000 48917	1	Coprileva	Lever cover	Couvre levier	Hebeldeckel	Cubre-palanca mando embr.	
	6	8000 98209	1	Comando gas completo	Throttle control compl.	Commande gaz compl.	Gasgriff kpl.	Accionam. acelerador compl.	
	7	8000 96832	1	Trasmissione comando frizione	Clutch transm.	Transm. com. embrayage	Führungssteuer. der Kupplung	Tran. mando embr. compl.	
	8	8000 62728	2	Vite	Screw	Vis	Schraube	Tornillo	
	9	8000 96833	1	Trasmissione comando gas	Throttle wire	Fil comm. gaz	Gaszugkabel	Trans. accionam. acelerador	
D	10	8000 A3699	1	Paracolpi per manubrio	Handlebar shock guard	Protection pour guidon	Lenkerschutz	Paracolpos por manillar	
	11	8BA0 77737	1	Leva frizione (L=24mm)	Clutch lever (L=24mm)	Levier embrayage (L=24mm)	Kupplungshebel (L=24mm)	Palanca mando embrague (L=24mm)	
D	11	80A0 77737	1	Leva frizione (L=24mm)	Clutch lever (L=24mm)	Levier embrayage (L=24mm)	Kupplungshebel (L=24mm)	Palanca mando embrague (L=24mm)	
	12	8000 38797	1	Vite	Screw	Vis	Schraube	Tornillo	
	15	8000 87812	1	Dado	Nut	Ecrou	Mutter	Tuerca	
	16	8000 48916	1	Gruppo registro	Adjuster set	Groupe reglage	Kupplungsreglergruppe	Grupo regul.	
	17	8000 62728	2	Vite	Screw	Vis	Schraube	Tornillo	
	18	8000 70698	1	Cavallotto	U-bolt	Cavalier	Bügelbolzen	Caballote	
	22	8A00 79754	1	Trasmissione decompressore	Decompression transm.	Trasm. décompression	Dekompressions Kabel	Transm. decompressore	
	25	8000 96828	1	Pulsante «Engine Stop»	«Engine Stop» button	Bouton «Engine Stop»	Drucktaste «Engine Stop»	Pulsador «Engine Stop»	
	26	8000 71578	2	Fascetta (L=78mm)	Clamp (L=78mm)	Collier (L=78mm)	Schelle (L=78mm)	Banda (L=78mm)	
	27	8000 56444	2	Fascetta (L=188mm)	Clamp (L=188mm)	Collier (L=188mm)	Schelle (L=188mm)	Banda (L=188mm)	
	30	8000 96835	1	Leva decompressore compl.	Decompression lever	Levier décompression	Dekompressions-hebel	Palanca decompressore	
D	34	8000 98463	2	Coprimanopole	Grip cover	Couvre poignée	Griffdeckel	Cubre manopla	

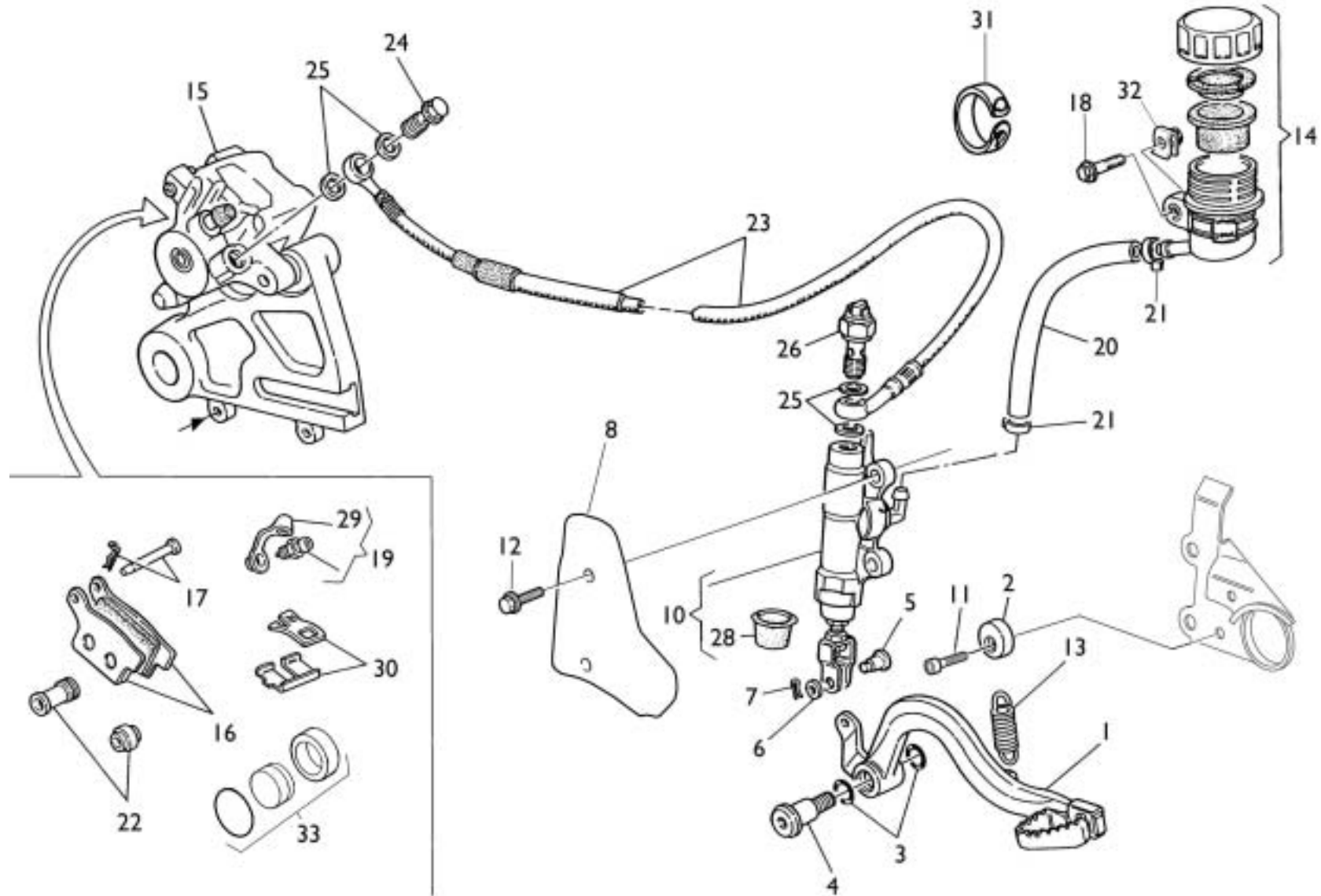



**SMR 630 Seel
replica**

TAVOLA
DRAWING
TABLE
BILD
TABLA

18

**FRENO IDRAULICO POSTERIORE - REAR HYDRAULIC BRAKE
FREIN HYDRAULIQUE ARRIERE - HINTERBREMSE
FRENO HIDRAULICO TRASERO**

Note Notes Notas	Pos. No. N. Index Pos.	N. Cod. Code No. Nr. Code Code Nr N. Cod.	Q.tà Q.ty Q.te M.ge C.ad	DENOMINAZIONE	NAME	DESIGNATION	BESHREIBUNG	DENOMINACION	Validità Validity Validité Gültig Validez
	1	8000 73343	1	Pedale comando freno	Brake control pedal	Pedal comm. frein	Bremspedal	Pedal accionamiento freno	
	2	8000 69125	1	Camma	Cam	Came	Nocken	Exéntrico	
	3	8000 22551	2	Anello OR	O-Ring	Bague OR	O-Ring	Anillo OR	
	4	8000 55902	1	Vite	Screw	Vis	Schraube	Tornillo	
	5	8000 70696	1	Perno	Pin	Pivot	Bolzen	Perno	
	6	8000 56377	1	Rosetta	Washer	Rondelle	Scheibe	Arandela	
	8	8000 98876	1	Protezione	Guard	Protection	Schutz	Protección	
	7	64N1 20068	1	Copiglia	Split pin	Goupille	Splint	Clavija	
	10	8000 76338	1	Pompa freno	Brake pump	Pompe frein	Bremspumpe	Bomba freno	
	11	8A00 55241	1	Vite	Screw	Vis	Schraube	Tornillo	
	12	8000 62727	2	Vite	Screw	Vis	Schraube	Tornillo	
	13	8A00 55903	1	Molla	Spring	Ressort	Feder	Resorte	
	14	8000 61078	1	Serbatoio olio completo	Oil tank assy	Reservoir huile compl.	Öltank Kpl.	Depósito aceite completo	
	15	8000 99729	1	Pinza freno completa	Brake caliper assy	Pince de frein, compl.	Bremszange, Kpl.	Pinza freno compl.	
	16	8000 79072	1	Coppia pastiglie	Pads pair	Paire plaquettes	Bremsbelagpaar	Pareja pastillas	
	17	8000 A0936	1	Perno	Pin	Pivot	Bolzen	Perno	
	18	8000 62727	1	Vite	Screw	Vis	Schraube	Tornillo	
	19	8000 A0931	1	Spurgo	Spurgo	Drain	Entleerung	Purga	
	20	8S00 66179	1	Tubazione	Pipe	Tuyau	Rohr	Tubo	
	21	8000 42349	2	Molletta	Spring	Ressort	Feder	Resorte	
	22	8000 79066	1	Cuffie	Boots	Poussiers	haube	Gorro	
	23	8A00 78326	1	Tubo mandata olio	Pipe	Tuyau	Rohr	Tubo	
	24	8000 57155	1	Vite	Screw	Vis	Schraube	Tornillo	
	25	8000 21480	4	Rosetta	Washer	Rondelle	Scheibe	Arandela	
	26	8000 57155	1	Vite	Screw	Vis	Schraube	Tornillo	
	28	8000 79075	1	Cuffia	Boot	Poussier	haube	Gorro	
	29	8000 53259	1	Parapolvere	Boots	Para-poudre	Schutzhaube	Para-polvo	
	30	8000 85932	1	Molla-lamierino	Spring-steel clip	Ressort	Feder	Rresorte	
	31	8000 53724	2	Fascetta	Guard	Protection	Schut	Proteccion	
	32	8000 46893	1	Dado	Bushing	Douille	Buchse	Manguito	
	33	8000 A0935	1	Pistone	Piston	Piston	Kolben	Pistòn	

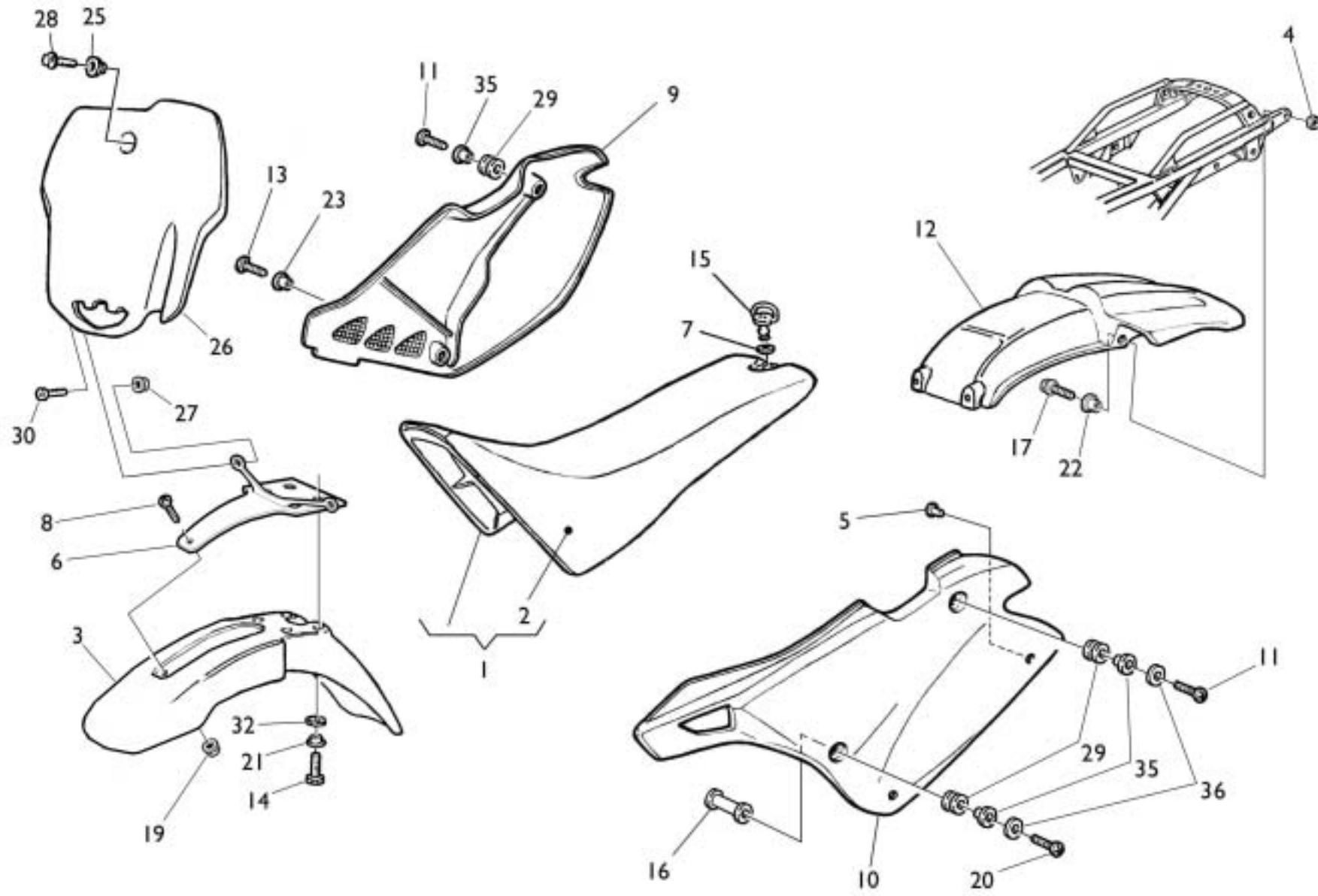



**SMR 630 Seel
replica**

TAVOLA
DRAWING
TABLE
BILD
TABLA

19

**PANNELLI, PARAFANGHI, SELLA - PANEL, FENDERS, SEAT
PANNEAU, GARDE-BOUES, SIEGE - STREIFEN, KOTFLUGEL, SATTEL
PANELO, GUARDABARROS, SILLIN**

Note Notes Marka Notas	Pos. No. N. Index Pos.	N. Cod. Code No. Nr. Code Code Nr N. Cod.	Q.tà Q.ty Q.te M.ge C.ad	DENOMINAZIONE	NAME	DESIGNATION	BESHREIBUNG	DENOMINACION	Validità Validity Validité Gültig Validez
	1	8000 A3691	1	Sella	Seat	Siège	Sattel	Sillín	
	2	8000 A0192	1	Rivestimento sella	Saddle covering	Revetement selle	Sattelverkleidung	Revestimiento sillín	
	3	8000 A1761	1	Parafango anteriore	Front mudguard	Garde-boue avant	Vord. Kotfluegel	Guarda-barros delantero	
	4	8000 44240	2	Dado	Nut	Ecrou	Mutter	Tuerca	
	5	8000 45490	2	Gommino	Rubber pad	Pièce caoutchouc	Gummstück	Junta de goma	
	6	8000 A3905	1	Supporto parafango ant.	Front mudguard holder	Support garde-boue avant	Vordere Kotfluegelhalter	Soporte guarda-barros del.	
	7	8000 69149	1	Rosetta elastica	Spring washer	Rondelle élastique	Federscheibe	Arandela elástica	
	8	8000 62727	1	Vite (M6x16 mm)	Screw (M6x16 mm)	Vis (M6x16 mm)	Schraube (M6x16 mm)	Tornillo (M6x16 mm)	
	9	8000 99515	1	Pannello destro	R.H. panel	Panneau, D.	Streifen, R.	Panel der.	
	10	8000 98375	1	Pannello sinistro	L.H. panel	Panneau, G.	Streifen, L.	Panel izq.	
	11	8000 62728	2	Vite anteriore (M6x20 mm)	Front screw (M6x20 mm)	Vis avant (M6x20 mm)	Vord. Schraube (M6x20 mm)	Tornillo del. (M6x20 mm)	
	12	8A00 A0546	1	Parafango posteriore	Rear mudguard	Garde-boue arriere	Hint.Kotfluegel	Guarda-barros trasero	
	13	8000 62729	1	Vite anteriore (M6x25 mm)	Front screw (M6x25 mm)	Vis avant (M6x25 mm)	Vord. Schraube (M6x25 mm)	Tornillo del. (M6x25 mm)	
	14	8000 62727	4	Vite (M6x16 mm)	Screw (M6x16 mm)	Vis (M6x16 mm)	Schraube (M6x16 mm)	Tornillo (M6x16 mm)	
	15	8000 69148	1	Perno	Pin	Pivot	Bolzen	Perno	
	16	1519 76703	1	Distanziale	Spacer	Entretoise	Distanzstück	Separador	
	17	8000 62728	2	Vite (M6x20 mm)	Screw (M6x20 mm)	Vis (M6x20 mm)	Schraube (M6x20 mm)	Tornillo (M6x20 mm)	
	19	8000 44240	1	Dado	Nut	Ecrou	Mutter	Tuerca	
	20	8C00 67545	1	Vite (M6x60 mm)	Screw (M6x60 mm)	Vis (M6x60 mm)	Schraube (M6x60 mm)	Tornillo (M6x60 mm)	
	21	8000 69429	2	Bussola	Bushing	Douille	Buchse	Manguito	
	22	8000 69429	2	Bussola	Bushing	Douille	Buchse	Manguito	
	23	8B00 44099	1	Bussola	Bushing	Douille	Buchse	Manguito	
	25	8B00 69282	1	Bussola	Bushing	Douille	Buchse	Manguito	
	26	80B0 87800	1	Portanumero	Number holder	Porte numero	Nummerträger	Porta numero	
	27	8000 44240	2	Dado	Nut	Ecrou	Mutter	Tuerca	
	28	8C00 67997	1	Vite (M5x20mm)	Screw (M5x20mm)	Vis (M5x20mm)	Schraube (M5x20mm)	Tornillo (M5x20mm)	
	29	8000 41862	4	Gommino	Rubber pad	Pièce caoutchouc	Gummstück	Junta de goma	
	30	8000 55878	2	Vite (M6x11mm)	Screw (M6x11mm)	Vis (M6x11mm)	Schraube (M6x11mm)	Tornillo (M6x11mm)	
	32	8000 48814	4	Rosetta	Washer	Rondelle	Scheibe	Arandela	
	35	8000 44099	3	Distanziale	Spacer	Entretoise	Distanzstück	Separador	
	36	8000 56359	2	Rosetta	Washer	Rondelle	Scheibe	Arandela	

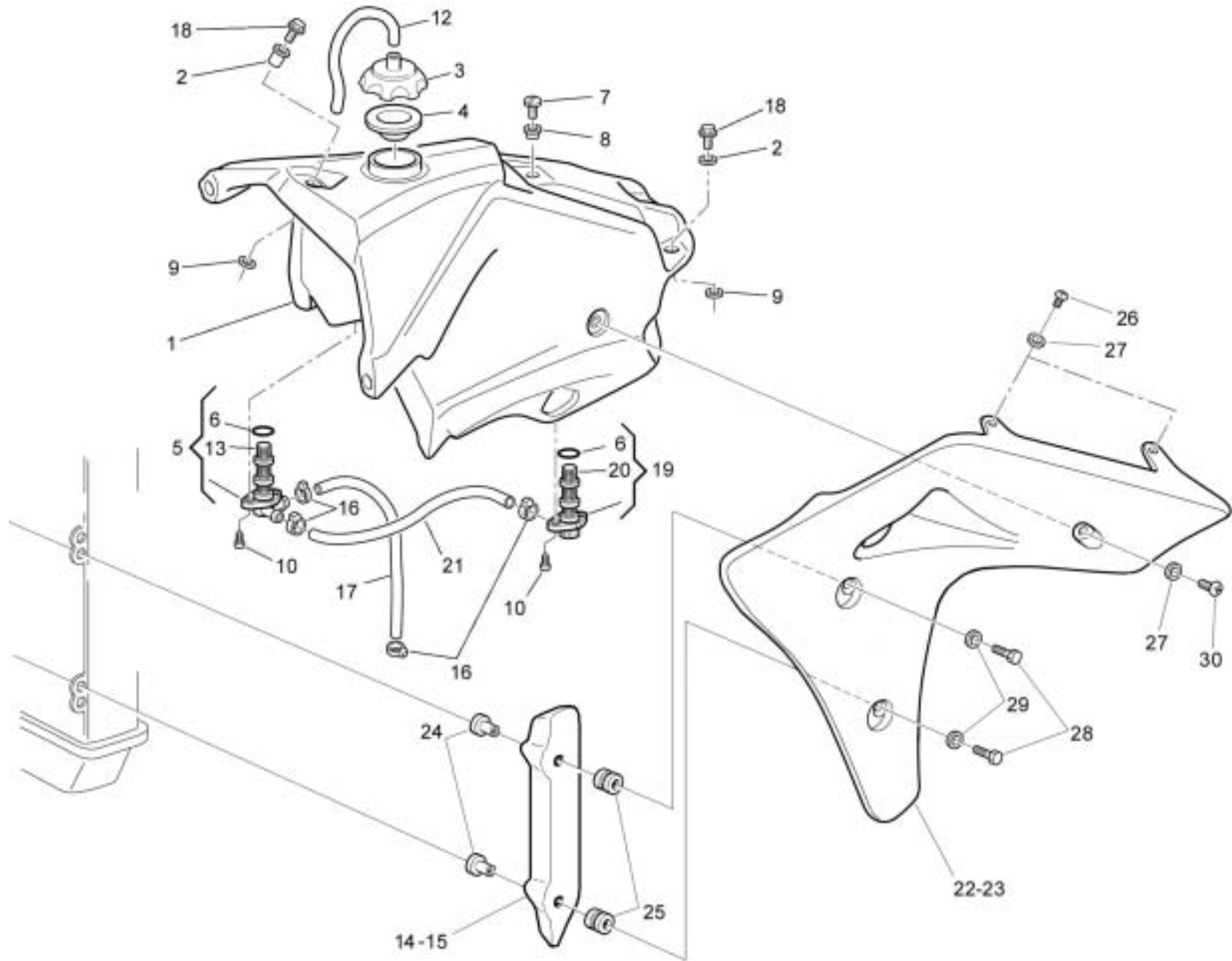



**SMR 630 Seel
replica**

TAVOLA
DRAWING
TABLE
BILD
TABLA

20

**SERBATOIO CARBURANTE, CONVOGLIATORI - GAS TANK, PANEL -
RESERVOIR CARBURANT, FLANC - KRAFTSTOFFBEHALTER, FLANKE -
DEPOSITO GASOLINA, LATERAL**

Note Notes Notas	Pos. No. Index Pos.	N. Cod. Code No. Nr. Code Code Nr N. Cod.	Q.tà Q.ty Q.te M.ge C.ad	DENOMINAZIONE	NAME	DESIGNATION	BESHREIBUNG	DENOMINACION	Validità Validity Validité Gültig Validez
	1	8A00 96819	1	Serbatoio carburante (l 9)	Fuel tank (l 9)	Réservoir essence (l 9)	Kraftstoffbehälter (l 9)	Depósito gasolina (l 9)	
	2	8000 30319	3	Rosetta piana	Washer	Rondelle	Scheibe	Arandela	
	3	8000 94098	1	Tappo	Plug	Bouchon	Verschluss	Tapón	
	4	8000 56381	1	Guarnizione	Gasket	Garniture	Dichtung	Junta	
	5	8000 66648	1	Rubinetto Dx.	R.H. cock	Robinet D.	R.Kraftstoffahn	Llave de paso der.	
	6	8000 01199	2	Anello OR	O-Ring	Bague OR	O-Ring	Anillo OR	
	7	60N1 04134	1	Vite	Screw	Vis	Schraube	Tornillo	
	8	8000 66238	1	Distanziale	Spacer	Entretoise	Distanzstück	Separador	
	9	8000 61362	3	Tampone	Pad	Tampon	Stopfen	Tampón	
	10	8000 37745	4	Vite	Screw	Vis	Schraube	Tornillo	
	12	8S00 68873	1	Tubetto sfiato	Battery breather pipe	Event batterie	Batterieentlüfter	Tubo de purga batería	
	13	8000 38748	1	Filtro benzina	Fuel filter	Filtre essence	Benzinfilter	Filtro gasolina	
	14	8000 A1414	1	Pannello Dx convogliatore	R.h. panel	Panel D.	Rechte Streifen	Panelo derecho	
	15	8000 A1415	1	Pannello sx convogliatore	L.h. panel	Panel G.	Linke Streifen	Panelo izquierdo	
	16	80A0 42349	4	Fascetta	Clamp	Collier	Schelle	Banda	
	17	8A00 94010	1	Condotta benzina (L=210 mm)	Pipe (L=210 mm)	Tuyau (L=210 mm)	Rohr (L=210 mm)	Tubo (L=210 mm)	
	18	8000 62726	3	Vite	Screw	Vis	Schraube	Tornillo	
	19	8000 67440	1	Rubinetto Sx.	L.H. cock	Robinet G.	L.Kraftstoffahn	Llave de paso izq.	
	20	8000 67700	1	Filtro benzina	Fuel filter	Filtre essence	Benzinfilter	Filtro gasolina	
	21	8C00 94010	1	Condotta benzina (L=260 mm)	Pipe (L=260 mm)	Tuyau (L=260 mm)	Rohr (L=260 mm)	Tubo (L=260 mm)	
	22	8000 98372	1	Conv. DX	R. side panel	Flanc D.	Flanke R.	Lateral D.	
	23	8000 98373	1	Conv. SX	L. side panel	Flanc G.	Flanke L.	Lateral I. (
	24	8000 44099	2	Distanziale	Spacer	Entretoise	Distanzstück	Separador	
	25	8000 41862	2	Gommino	Rubber	Pièce de caoutchouch	Gummstück	Junta de goma	
	26	8000 36467	4	Vite (M6x10 mm)	Screw (M6x10 mm)	Vis (M6x10 mm)	Schraube (M6x10 mm)	Tornillo (M6x10 mm)	
	27	8000 56391	6	Rosetta	Washer	Rondelle	Scheibe	Arandela	
	28	8000 62729	4	Vite (M6x25 mm)	Screw (M6x25 mm)	Vis (M6x25 mm)	Schraube (M6x25 mm)	Tornillo (M6x25 mm)	
	29	8000 56359	4	Rosetta	Washer	Rondelle	Scheibe	Arandela	
	30	8000 62727	2	Vite (M6x16 mm)	Screw (M6x16 mm)	Vis (M6x16 mm)	Schraube (M6x16 mm)	Tornillo (M6x16 mm)	

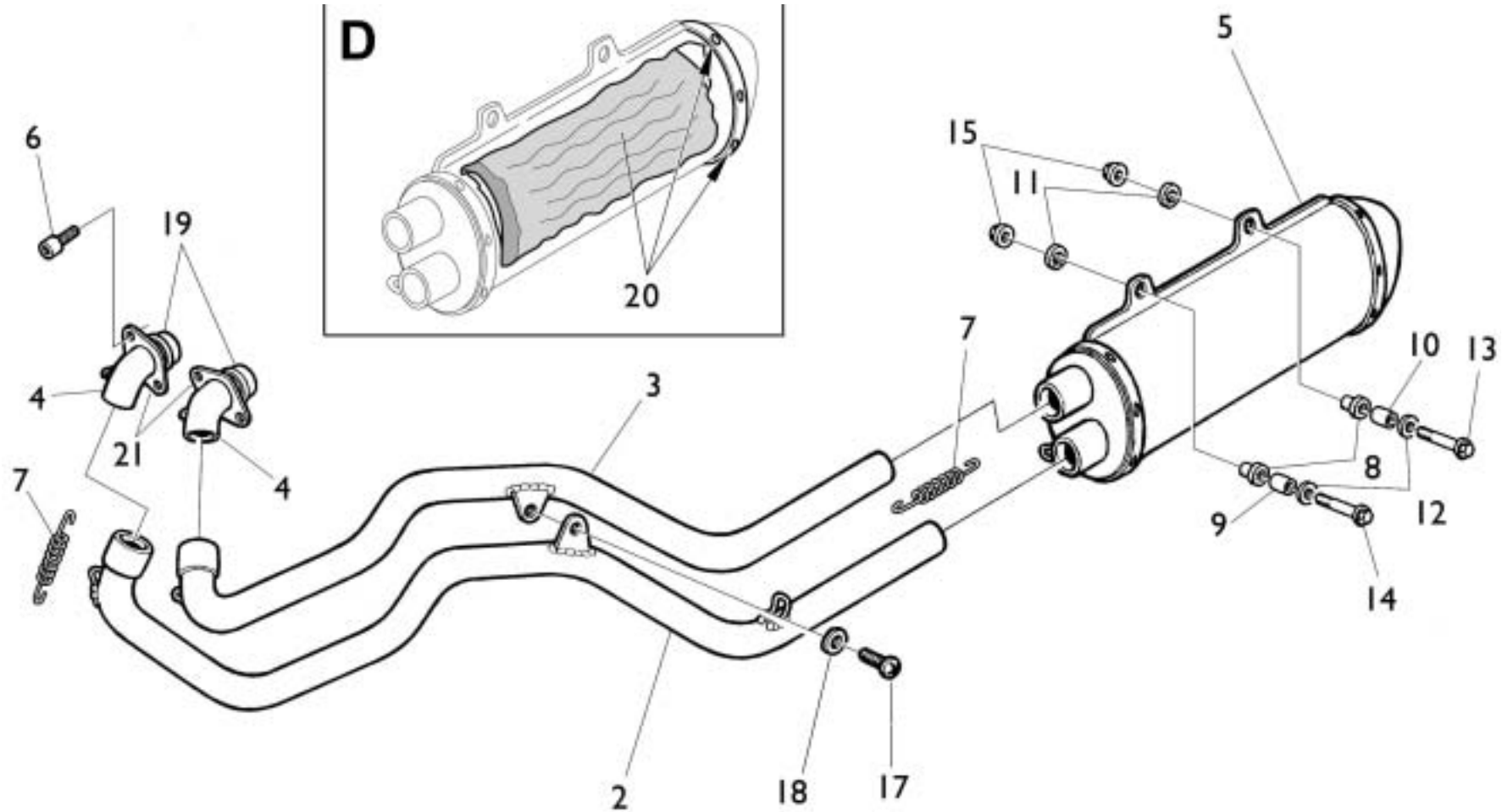

1: 2, 3, 4, 5, 7, 9, 10, 17, 18, 19, 20, 21



**SMR 630 Seel
replica**

TAVOLA
DRAWING
TABLE
BILD
TABLA

21

**SCARICO- EXHAUST SYSTEM
TUYAU D'ECHAPPEMENT - AUSPUFFROHR
TUBO DE ESCAPE**

Note Notes Marke Notas	Pos. No. Index Pos.	N. Cod. Code No. Nr. Code Code Nr N. Cod.	Q.tà Q.ty Q.te M.ge C.ad	DENOMINAZIONE	NAME	DESIGNATION	BESHREIBUNG	DENOMINACION	Validità Validity Validité Gültig Validez
	1	8A00 98388	1	Ass. scarico	Exhaust system assy	Groupe tuyau d'échapp	Auspuffrohrgruppe Kpl.	Grupo tubo de escape	
	1	8B00 98388	1	Ass. scarico (U.S.A.)	Exhaust system assy (U.S.A.)	Gr. tuyau d'échapp (U.S.A.)	Auspuffrohrgr. Kpl. (U.S.A.)	Gr. tubo escape (U.S.A.)	
	2	8000 98390	1	Tubo di scarico Dx	R.H. exhaust pipe	Tuyau d'échapp. D..	Auspuffrohr R..	Tubo de escape der	
	3	8A00 98391	1	Tubo di scarico Sx	L.H. exhaust pipe.	Tuyau d'échapp. G..	Auspuffrohr L..	Tubo de escape izq.	
	4	8000 98392	1	Raccordo Dx tubo scarico	R.h. union exhaust pipe	Raccord D. tuyau d'échapp.	Rechte Anschluss Auspuffrohr	Empalme der. tubo de escape	
	4	8000 A0565	1	Raccordo Sx tubo scarico	L.h. union exhaust pipe	Raccord G. tuyau d'échapp.	Linke Anschluss Auspuffrohr	Empalme iz. tubo de escape	
	5	8000 98395	1	Silenziatore	Exhaust silencer	Silencieux d'échappement	Schalldämpfer	Silenciador de escape	
	5	8000 93049	1	Silenziatore (U.S.A.)	Exhaust silencer (U.S.A.)	Silencieux d'échapp. (U.S.A.)	Schalldämpfer (U.S.A.)	Silenc. de escape (U.S.A.)	
	6	60N4 07335	4	Vite	Screw	Vis	Schraube	Tornillo	
	7	8000 67496	4	Molla	Spring	Ressort	Feder	Resorte	
	8	1514 10702	2	Distanziale in gomma	Rubber spacer	Entretoise en caoutchouc	Gummi Distanzstück	Separador de goma	
	9	8H00 70379	1	Distanziale	Spacer	Entretoise	Distanzstück	Separador	
	10	8L00 70379	1	Distanziale	Spacer	Entretoise	Distanzstück	Separador	
	11	1513 41401	2	Rosetta in gomma	Rubber washer	Rondelle en caoutchouc	Gummischeibe	Arandela de goma	
	12	1513 74301	2	Rosetta	Washer	Rondelle	Scheibe	Arandela	
	13	8000 67545	1	Vite (M6x50 mm)	Screw (M6x50 mm)	Vis (M6x50 mm)	Schraube (M6x50 mm)	Tornillo (M6x50 mm)	
	14	8D00 67545	1	Vite (M6x60 mm)	Screw (M6x60 mm)	Vis (M6x60 mm)	Schraube (M6x60 mm)	Tornillo (M6x60 mm)	
	15	8000 44240	2	Dado	Nut	Ecrou	Mutter	Tuerca	
	17	8000 60898	1	Vite	Screw	Vis	Schraube	Tornillo	
	18	8000 60969	1	Rosetta	Washer	Rondelle	Scheibe	Arandela	
	19	8000 98394	2	Terminale per tubo di scarico	Exhaust pipe end	Terminal tuyau d'échapp.	Anschluss Auspuffrohr	Terminal tubo de escape	
D	20	8000 98544	1	Kit per silenziatore	Silencer packaging kit	Set silencieux	Schalldämpfer Kit	Kit silenciador	
	21	8000 98393	2	Flangia	Flange	Bride	Flansch	Brida	

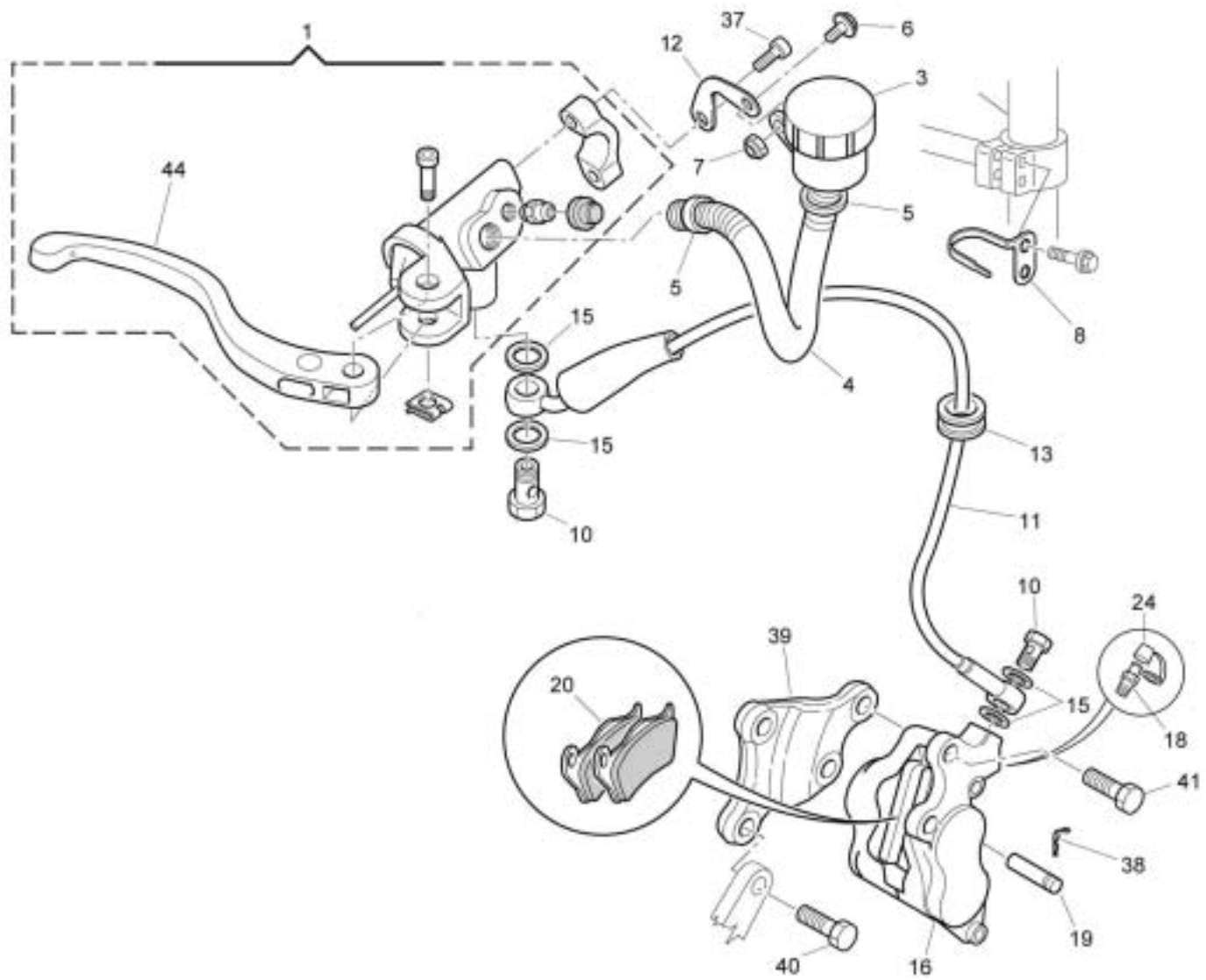



**SMR 630 Seel
replica**

TAVOLA
DRAWING
TABLE
BILD
TABLA

22

**FRENO IDRAULICO ANTERIORE - FRONT HYDRAULIC BRAKE
FREIN HYDRAULIQUE AVANT - VORDERBREMSE
FRENO HIDRAULICO DELANTERO**

Note Notes Notes Marke Notas	Pos. No. N. Index Pos.	N. Cod. Code No. Nr. Code Code Nr N. Cod.	Q.tà Q.ty Q.te M.ge C.ad	DENOMINAZIONE	NAME	DESIGNATION	BESHREIBUNG	DENOMINACION	Validità Validity Validité Gültig Validez
	1	8000 96759	1	Pompa comando freno ant.	Brake pump	Pompe frein	Bremspumpe	Bomba freno	
	3	8000 61078	1	Serbatoio	tank	Réservoir	Tank	Depòsito	
	4	8L00 66179	1	Tubo olio	Pipe	Tuyau	Rohr	Tubo	
	5	8B00 95276	2	Fascetta	Clamp	Collier	Schelle	Banda	
	6	8000 62727	2	Vite (M6x15mm)	Screw (M6x15mm)	Vis (M6x15mm)	Schraube (M6x15mm)	Tornillo (M6x15mm)	
	7	8000 44240	1	Dado	Nut	Ecrou	Mutter	Tuerca	
	8	8000 99299	1	Piastrina di ritegno	Plate	Plaque	Platte	Placa	
	10	8000 57155	2	Vite	Screw	Vis	Schraube	Tornillo	
	11	8000 93036	1	Tubo mandata olio	Pipe	Tuyau	Rohr	Tubo	
	12	8000 99162	1	Piastrina di ritegno	Plate	Plaque	Platte	Placa	
	13	8000 71806	1	Occhiello passatubo	Fairlead	Passe câble	Kabelführung	Prensa cable	
	15	8000 21480	4	Rosetta	Washer	Rondell'e	Scheibe	Arandela	
	16	8000 93216	1	Pinza freno	Brake caliper	Etrier frein	Bremssattel	Pinza	
	18	8000 94412	1	Spurgo	Spurgo	Drain	Entleerung	Purga	
	19	8000 94414	1	Perno	Pin	Pivot	Bolzen	Perno	
	20	8000 94411	1	Coppia pastiglie	Pads pair	Paire plaquettes	Bremsbelagpaar	Pareja pastillas	
	24	8000 94413	1	Parapolvere	Boots	Para-poudre	Schutzhaube	Para-polvo	
	37	8000 62729	2	Vite	Screw	Vis	Schraube	Tornillo	
	38	8000 94415	1	Molletta di ritegno	Retaining spring	Ressort	Feder	Resorte	
	39	8A00 95599	1	Supporto	Holder	Support	Halterung	Soporte	
	40	8A00 94060	2	Vite	Screw	Vis	Schraube	Tornillo	
	41	8000 94060	2	Vite	Screw	Vis	Schraube	Tornillo	
D	44	8000 A3629	1	Leva	Lever	Levier	Hebel	Palanca	
D	45	8A00 A3630	1	Kit paramani	Guards Kit	Kit protection	Schutzgruppe kpl	Grupo protection	

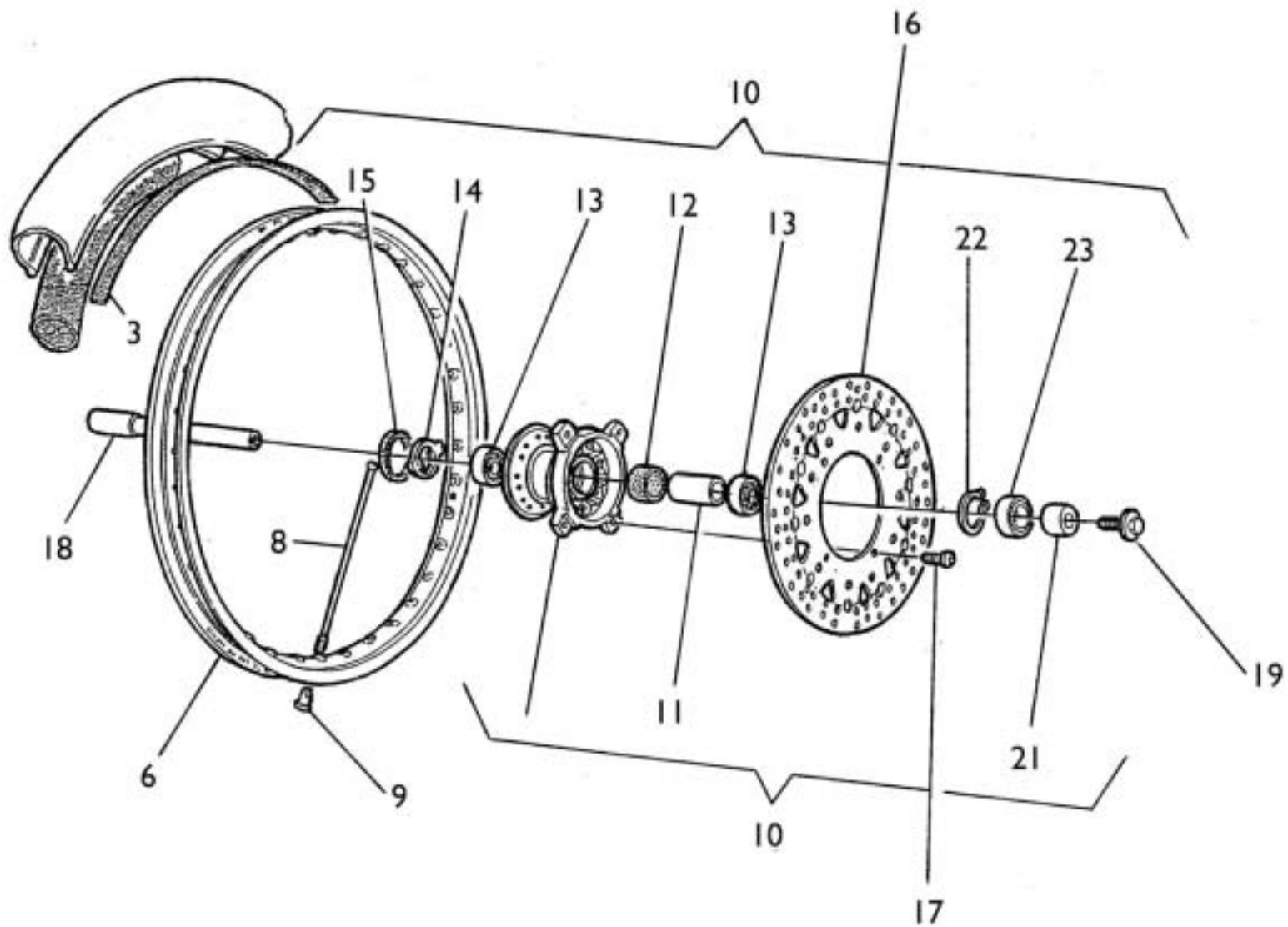



**SMR 630 Seel
replica**

TAVOLA
DRAWING
TABLE
BILD
TABLA

23

**RUOTA ANTERIORE - FRONT WHEEL
ROUE AV. - VORTERRAD
RUEDA DELANTERA**

Note Notes Markes Notas	Pos. No. N. Index Pos.	N. Cod. Code No. Nr. Code Code Nr N. Cod.	Q.tà Q.ty Q.te M.ge C.ad	DENOMINAZIONE	NAME	DESIGNATION	BESHREIBUNG	DENOMINACION	Validità Validity Validité Gültig Validez
	3	8B00 82879	1	Fascia copriraggi	Rim strip	Bande	Band	Banda	
	6	8000 A3685	1	Cerchio (3,5x16,5")	Rim (3,5x16,5")	Jante (3,5x16,5")	Felge (3,5x16,5")	Llanta (3,5x16,5")	
	8	8000 A3786	36	Raggio	Spoke	Bras	Speiche	Radio	
	9	69N4 29004	36	Nipplo	Nipple	Nipple	Nippel	Nipple	
	10	8B00 96838	1	Mozzo completo	Hub assy	Moyeau compl.	Radnabe, Kpl.	Cubo compl.	
	11	8000 96928	1	Distanziale	Spacer	Entretoise	Distanzstück	Separador	
	12	8000 92797	1	Portadistanziale	Spacer holder	Porte-entretoise	Abstandstückhalter	Porta-distancial	
	13	8000 84938	2	Cuscinetto a sfere (ø25xø42x9mm)	Ball bearing (ø25xø42x9mm)	Roulement à billes (ø25xø42x9mm)	Kugellager (ø25xø42x9mm)	Cojinete de bolas (ø25xø42x9mm)	
	15	8A00 92986	1	Anello di tenuta (ø28xø50x5mm)	Seal ring (ø28xø50x5mm)	Bague d'étanchéité (ø28xø50x5mm)	Dichtungsring (ø28xø50x5mm)	Anillo de retención (ø28xø50x5mm)	
	16	8000 A1709	1	Disco freno (ø320mm; S= 4mm)	Brake disc (ø320mm; S= 4mm)	Disque frein (ø320mm; S= 4mm)	Bremsscheibe (ø320mm; S= 4mm)	Disco freno (ø320mm; S= 4mm)	
	17	8A00 92876	4	Vite	Screw	Vis	Schraube	Tornillo	
	18	8A00 96932	1	Perno ruota	Pin	Pivot	Bolzen	Perno rueda	
	19	8000 96933	1	Vite	Screw	Vis	Schraube	Tornillo	
	21	8A00 96930	1	Distanziale	Spacer	Entretoise	Distanzstück	Separador	
	22	66N0 21270	1	Anello SEEGER	SEEGER ring	Anneeau SEEGER	Ring SEEGER	Anillo SEEGER	
	23	8000 22966	1	Distanziale	Spacer	Entretoise	Distanzstück	Separador	

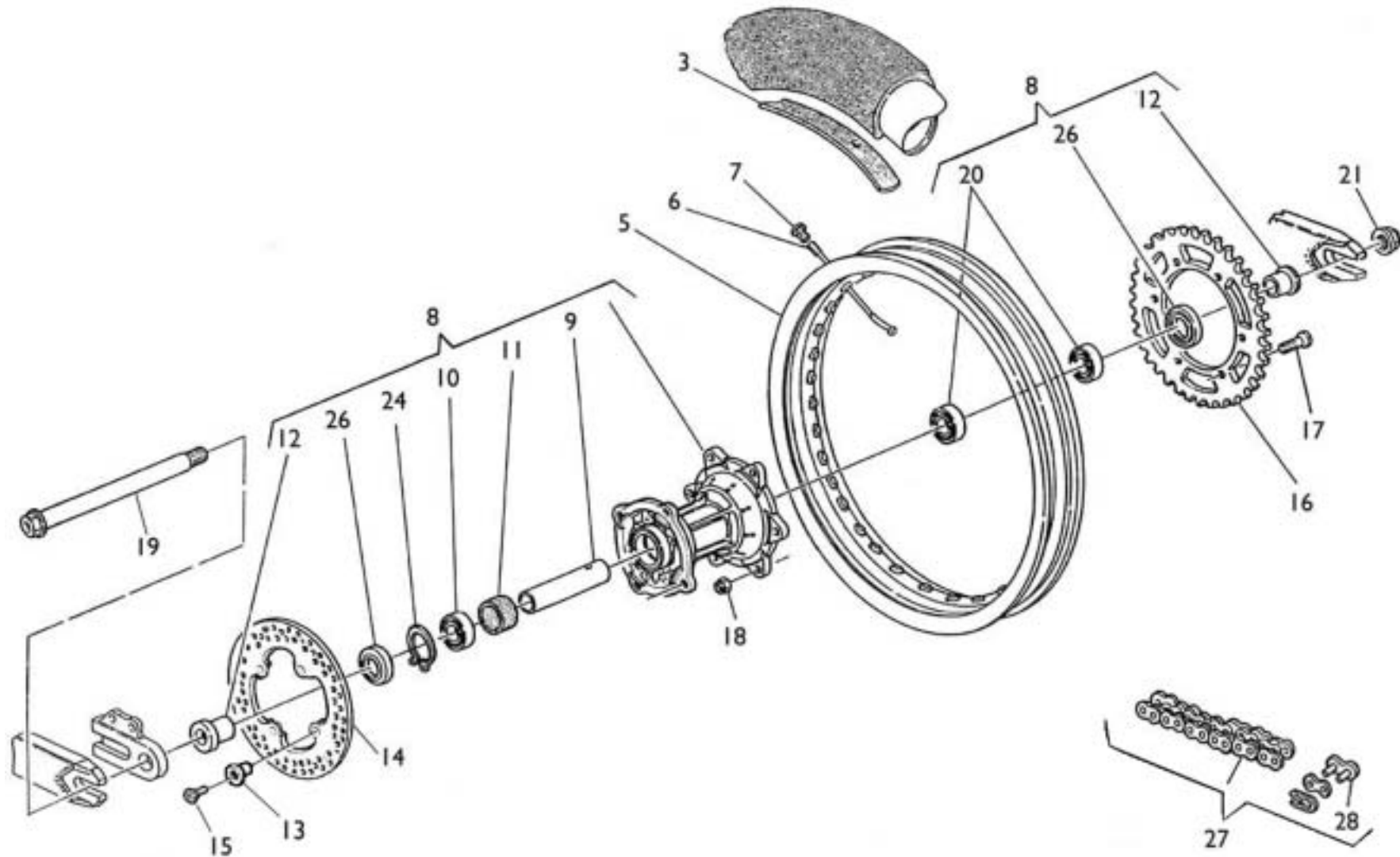



**SMR 630 Seel
replica**

TAVOLA
DRAWING
TABLE
BILD
TABLA

24

**RUOTA POSTERIORE - REAR WHEEL
ROUE ARRIERE - HINTERRAD
RUEDA TRASERA**

Note Notes Notas	Pos. No. Index Pos.	N. Cod. Code No. Nr. Code Code Nr N. Cod.	Q.tà Q.ty Q.te M.ge C.ad	DENOMINAZIONE	NAME	DESIGNATION	BESHREIBUNG	DENOMINACION	Validità Validity Validité Gültig Validez
	3	8B00 82879	1	Fascia copriraggi	Rim strip	Bande	Band	Banda	
	5	8000 A3688	1	Cerchio (5 x 17")	Rim (5 x 17")	Jante (5 x 17")	Felge (5 x 17")	Llanta (5 x 17")	
	6	8000 94757	18	Raggio lato SINISTRO	Spoke (L.H. side)	Bras (cote gauche)	Speiche (linke Seite)	Radio (lado izquierdo)	
	6	8000 95341	18	Raggio lato DESTRO	Spoke (R.H. side)	Bras (cote gauche)	Speiche (rechte Seite)	Radio (lado derecho)	
	7	69N4 29005	36	Nipplo	Nipple	Nipple	Nippel	Nipple	
	8	8000 96937	1	Mozzo completo	Hub assy	Moyeau compl.	Radnabe, Kpl.	Cubo compl.	
	9	8000 92414	1	Distanziale	Spacer	Entretoise	Distanzstück	Separador	
	10	8B00 26846	1	Cuscinetto(ø25xø47x16 mm)	Bearing (ø25xø47x16 mm)	Roulement (ø25xø47x16 mm)	Kugellager (ø25xø47x16 mm)	Cojinete (ø25xø47x16 mm)	
	11	8000 92797	1	Porta distanziale	Spacer	Entretoise	Distanzstück	Separador	
	12	8000 96938	2	Distanziale	Spacer	Entretoise	Distanzstück	Separador	
	13	8000 A0693	4	Boccola	Bush	Douille	Buchse	Manguito	
	14	8000 A0692	1	Disco freno (ø220 mm)	Brake disc (ø220 mm)	Disque frein (ø220 mm)	Bremsscheibe (ø220 mm)	Disco freno (ø220 mm)	
	15	8000 62726	4	Vite	Screw	Vis	Schraube	Tornillo	
	16	8G00 96837	1	Corona (Z = 48)	Ring gear (Z = 48)	Couronne (Z = 48)	Kranz (Z = 48)	Corona (Z = 48)	
D	16	8A00 96837	1	Corona (Z = 47)	Ring gear (Z = 47)	Couronne (Z = 47)	Kranz (Z = 47)	Corona (Z = 47)	
D	16	8C00 96837	1	Corona (Z = 49)	Ring gear (Z = 49)	Couronne (Z = 49)	Kranz (Z = 49)	Corona (Z = 49)	
	17	8C00 40796	6	Vite	Screw	Vis	Schraube	Tornillo	
	18	8000 43928	6	Dado	Nut	Ecrou	Mutter	Tuierca	
	19	8000 96940	1	Perno	Pin	Pivot	Bolzen	Perno	
	20	8A00 26846	2	Cuscinetto (ø25xø47x12 mm)	Bearing (ø25xø47x12 mm)	Roulement (ø25xø47x12 mm)	Kugellager (ø25xø47x12 mm)	Cojinete (ø25xø47x12 mm)	
	21	8000 93072	1	Dado	Nut	Ecrou	Mutter	Tuerca	
	24	66N0 21272	1	Anello SEEGER	SEEGER ring	Anneau SEEGER	Ring SEEGER	Anillo SEEGER	
	26	8000 89572	2	Anello di tenuta (ø32xø47x7 mm)	Seal ring (ø32xø47x7 mm)	Bague d'étanchéité (ø32xø47x7 mm)	Dichtungsring (ø32xø47x7 mm)	Anillo de retención (ø32xø47x7 mm)	
	27	8A00 79785	1	Catena 5/8"x6,5 (116 maglie)	Chain 5/8"x6,5 (116 link)	Chaîne 5/8"x6,5 (116 maillon)	Kette 5/8"x6,5 (116 Schake)	Cadena 5/8"x6,5 (116 malla)	
	28	8000 79790	1	Giunto	Coupling	Joint	Kupplung	Junta	

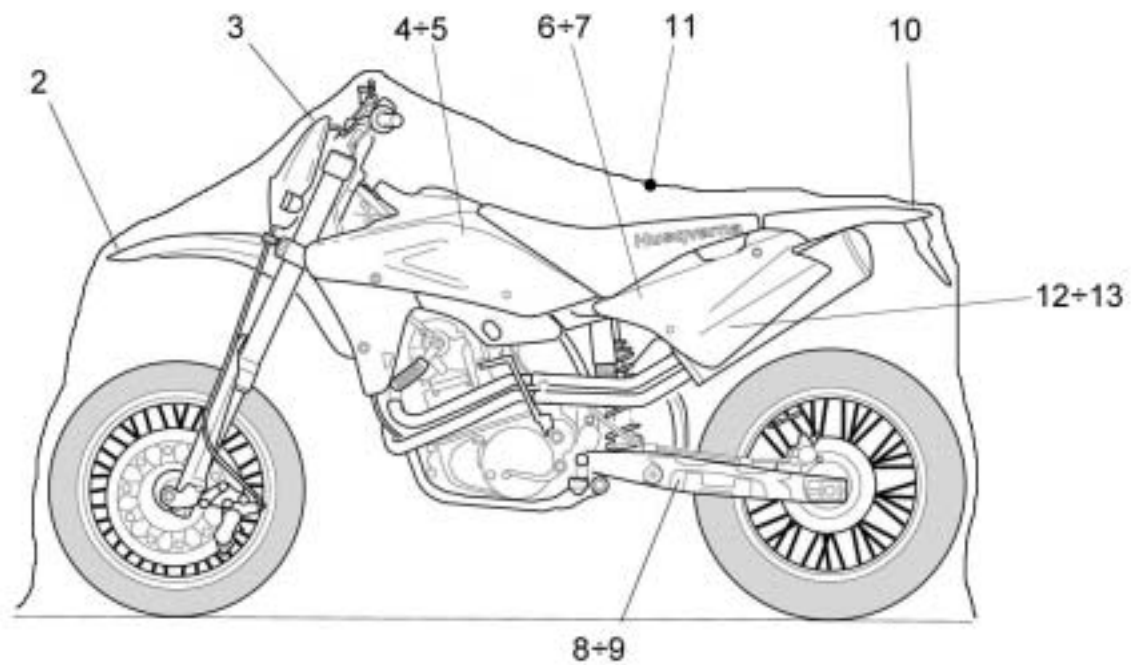

DISEGNO DRAWING DESSIN ZEICHNUNG DIBUJO	TAVOLA DRAWING TABLE BILD TABLA	INDEX NO. POS. N. INDICE	DISEGNO DRAWING DESSIN ZEICHNUNG DIBUJO	TAVOLA DRAWING TABLE BILD TABLA	INDEX NO. POS. N. INDICE	DISEGNO DRAWING DESSIN ZEICHNUNG DIBUJO	TAVOLA DRAWING TABLE BILD TABLA	INDEX NO. POS. N. INDICE	DISEGNO DRAWING DESSIN ZEICHNUNG DIBUJO	TAVOLA DRAWING TABLE BILD TABLA	INDEX NO. POS. N. INDICE	DISEGNO DRAWING DESSIN ZEICHNUNG DIBUJO	TAVOLA DRAWING TABLE BILD TABLA	INDEX NO. POS. N. INDICE	DISEGNO DRAWING DESSIN ZEICHNUNG DIBUJO	TAVOLA DRAWING TABLE BILD TABLA	INDEX NO. POS. N. INDICE
1511 33302	16	16	1612 41501	8	48	60N1 02510	6	15	8000 29043	12	43	8000 45194	2	26	8000 59942	2	28
1513 41401	21	11	1612 48001	8	20	60N1 02513	6	6	8000 30319	20	2	8000 45194	7	71	8000 59965	8	2
1513 71301	4	4	1612 48101	8	19	60N1 02522	5	38	8000 30326	8	36	8000 45490	19	5	8000 59975	7	3
1513 71401	8	47	1612 69901	8	39	60N1 02525	5	6	8000 31271	7	66	8000 45495	11	17	8000 59976	7	4
1513 72201	6	29	1612 84201	8	22	60N1 02555	12	22	8000 33373	12	12	8000 46881	3	38	8000 59977	6	17
1513 72602	6	3	1614 59002	7	7	60N1 02555	13	65	8000 34609	6	40	8000 46893	5	5	8000 60463	8	45
1513 72602	7	19	1614 72801	9	15	60N1 02594	13	62	8000 35823	8	35	8000 46893	11	8	8000 60464	6	36
1513 74301	21	12	1615 01404	6	27	60N1 02866	7	16	8000 36091	13	60	8000 46893	15	29	8000 60470	8	55
1514 10702	21	8	1615 02301	2	14	60N1 04134	20	7	8000 36137	10	17	8000 46893	18	32	8000 60472	7	72
1514 13401	1	6	1615 02501	2	12	60N4 07335	21	6	8000 36137	14	31	8000 47422	7	25	8000 60472	8	38
1515 59101	1	5	1615 03601	3	17	61N1 15062	8	8	8000 36467	20	26	8000 47708	2	20	8000 60473	8	37
1515 80301	11	10	1615 04201	3	13	61N1 15195	3	22	8000 36786	7	46	8000 47763	7	53	8000 60474	7	40
1517 94701	1	1	1615 04301	3	8	62N0 15682	6	43	8000 36856	8	53	8000 48138	8	13	8000 60475	7	36
1517 94902	1	8	1615 04501	3	11	62N1 15504	6	9	8000 36857	8	51	8000 48801	5	39	8000 60476	7	6
1519 65301	1	2	1615 04901	3	7	62N1 15519	5	28	8000 37299	3	20	8000 48814	19	32	8000 60477	7	57
1519 76703	19	16	1615 05802	4	17	62N1 15567	3	37	8000 37745	20	10	8000 48916	17	16	8000 60577	7	63
1519 80501	1	4	1615 08401	3	27	62N1 15658	3	6	8000 38110	7	30	8000 48917	17	5	8000 60577	7	76
1519 84701	1	13	1615 08501	3	28	62N4 15548	9	13	8000 38521	16	9	8000 50322	3	47	8000 60873	5	23
1610 77601	7	8	1615 09501	3	12	64N1 20068	12	8	8000 38748	20	13	8000 50453	5	25	8000 60898	12	40
1610 77701	6	33	1615 09601	3	9	64N1 20068	18	7	8000 38767	16	15	8000 53259	18	29	8000 60898	21	17
1610 77701	7	10	1615 09801	4	3	66N0 21205	7	31	8000 38797	17	12	8000 53339	2	38	8000 60969	10	14
1611 08401	7	73	1615 10501	7	15	66N0 21208	7	70	8000 40427	5	34	8000 53724	18	31	8000 60969	21	18
1611 08501	7	67	1615 11602	6	26	66N0 21211	6	21	8000 40449	7	29	8000 54477	8	4	8000 61078	18	14
1611 21601	7	27	1615 12301	3	24	66N0 21211	8	24	8000 41758	5	35	8000 54692	8	7	8000 61078	22	3
1611 27101	7	28	1615 12802	3	21	66N0 21270	23	22	8000 41862	19	29	8000 55878	19	30	8000 61263	7	5
1611 65003	7	13	1615 13302	1	3	66N0 21272	24	24	8000 41862	20	25	8000 55902	18	4	8000 61269	7	74
1611 67702	7	35	1615 14103	3	19	69N4 29004	23	9	8000 42022	15	31	8000 56359	15	27	8000 61275	4	18
1611 68001	7	33	1615 15601	3	10	69N4 29005	24	7	8000 42022	16	26	8000 56359	19	36	8000 61314	13	63
1611 68101	7	34	1615 26602	3	4	6BN0 21509	8	15	8000 42023	16	12	8000 56359	20	29	8000 61355	13	53
1611 68401	7	24	1615 27501	9	14	8000 01199	20	6	8000 42023	16	18	8000 56377	18	6	8000 61362	20	9
1611 68601	7	21	1615 28801	2	11	8000 01412	16	19	8000 42278	2	21	8000 56381	20	4	8000 62725	5	26
1611 69201	7	22	1615 29401	2	10	8000 02124	3	1	8000 42349	18	21	8000 56391	20	27	8000 62725	5	27
1611 69901	8	32	1615 29601	2	13	8000 08536	2	44	8000 43715	5	4	8000 56410	6	31	8000 62726	20	18
1611 70101	8	40	1615 30301	2	17	8000 08536	14	10	8000 43789	6	5	8000 56443	13	72	8000 62726	24	15
1611 70401	7	61	1615 31502	8	3	8000 17810	14	21	8000 43928	12	16	8000 56444	17	27	8000 62727	10	13
1611 70601	7	62	1615 34801	7	14	8000 18422	2	32	8000 43928	12	46	8000 56806	11	21	8000 62727	11	2
1611 70801	2	8	1615 35801	2	3	8000 19768	6	25	8000 43928	14	30	8000 57155	18	24	8000 62727	15	24
1611 70801	7	39	1615 38201	9	4	8000 19789	2	49	8000 43928	24	18	8000 57155	18	26	8000 62727	18	12
1611 71501	8	44	1615 38801	8	30	8000 20536	14	14	8000 44099	19	35	8000 57155	22	10	8000 62727	18	18
1611 71701	8	25	1615 39101	7	32	8000 21375	3	29	8000 44099	20	24	8000 57196	4	24	8000 62727	19	8
1611 74601	7	38	1615 39301	3	15	8000 21480	6	20	8000 44240	5	20	8000 57242	5	13	8000 62727	19	14
1611 81604	6	14	1615 40702	2	2	8000 21480	18	25	8000 44240	11	11	8000 59289	14	24	8000 62727	20	30
1611 83701	8	27	1615 40802	3	23	8000 21480	22	15	8000 44240	13	73	8000 59433	12	19	8000 62727	22	6
1612 35701	8	43	1616 36201	7	37	8000 21535	8	61	8000 44240	14	33	8000 59434	12	21	8000 62728	5	10
1612 36101	8	49	1617 95501	2	37	8000 22551	18	3	8000 44240	15	28	8000 59801	5	9	8000 62728	11	20
1612 36201	8	18	1619 69801	1	16	8000 22966	23	23	8000 44240	19	4	8000 59802	5	7	8000 62728	17	8
1612 36301	8	21	60N1 01081	8	17	8000 23110	6	37	8000 44240	19	19	8000 59803	5	8	8000 62728	17	17
1612 36502	8	41	60N1 02482	10	16	8000 26884	6	12	8000 44240	19	27	8000 59939	3	14	8000 62728	19	11
1612 38401	8	33	60N1 02487	9	8	8000 27960	7	45	8000 44240	21	15	8000 59940	2	36	8000 62728	19	17
1612 38801	8	46	60N1 02504	7	75	8000 28182	6	4	8000 44240	22	7	8000 59941	3	35	8000 62729	13	40
1612 39001	8	23															

DISEGNO DRAWING DESSIN ZEICHNUNG DIBUJO	TAVOLA DRAWING TABLE BILD TABLA	INDEX NO. POS. N. INDICE	DISEGNO DRAWING DESSIN ZEICHNUNG DIBUJO	TAVOLA DRAWING TABLE BILD TABLA	INDEX NO. POS. N. INDICE	DISEGNO DRAWING DESSIN ZEICHNUNG DIBUJO	TAVOLA DRAWING TABLE BILD TABLA	INDEX NO. POS. N. INDICE	DISEGNO DRAWING DESSIN ZEICHNUNG DIBUJO	TAVOLA DRAWING TABLE BILD TABLA	INDEX NO. POS. N. INDICE	DISEGNO DRAWING DESSIN ZEICHNUNG DIBUJO	TAVOLA DRAWING TABLE BILD TABLA	INDEX NO. POS. N. INDICE	DISEGNO DRAWING DESSIN ZEICHNUNG DIBUJO	TAVOLA DRAWING TABLE BILD TABLA	INDEX NO. POS. N. INDICE
8000 62729	19	13	8000 69156	2	29	8000 80277	12	13	8000 93036	22	11	8000 98179	6	35	8000 98520	15	6
8000 62729	20	28	8000 69282	13	69	8000 80455	4	12	8000 93049	21	5	8000 98179	7	12	8000 98544	21	20
8000 62729	22	37	8000 69282	14	25	8000 82337	3	3	8000 93072	24	21	8000 98180	7	44	8000 98548	15	6
8000 62795	14	8	8000 69315	13	57	8000 83333	8	10	8000 93114	8	50	8000 98185	10	4	8000 98782	13	78
8000 62796	12	14	8000 69429	15	23	8000 83335	8	57	8000 93116	8	1	8000 98186	10	3	8000 98783	13	79
8000 62796	13	2	8000 69429	19	21	8000 84938	23	13	8000 93124	16	11	8000 98196	10	2	8000 98784	13	80
8000 63312	12	20	8000 69429	19	22	8000 85245	4	16	8000 93156	12	6	8000 98201	10	7	8000 98785	13	81
8000 63424	8	42	8000 69736	8	28	8000 85322	9	7	8000 93173	4	10	8000 98203	10	12	8000 98876	18	8
8000 63425	8	9	8000 69737	8	54	8000 85354	2	55	8000 93216	22	16	8000 98205	2	16	8000 98896	27	8
8000 63817	2	9	8000 69769	7	1	8000 85932	18	30	8000 93283	13	70	8000 98207	10	15	8000 98897	27	9
8000 63821	8	26	8000 70215	7	80	8000 86136	16	8	8000 94060	22	41	8000 98209	17	6	8000 99162	22	12
8000 63822	8	56	8000 70216	7	81	8000 86136	16	21	8000 94098	20	3	8000 98215	10	18	8000 99299	22	8
8000 63829	6	22	8000 70217	7	82	8000 86137	16	22	8000 94411	22	20	8000 98245	10	1	8000 99515	19	9
8000 63831	6	22	8000 70637	1	10	8000 86140	16	7	8000 94412	22	18	8000 98250	10	8	8000 99658	5	1
8000 64726	2	5	8000 70696	18	5	8000 86176	16	3	8000 94413	22	24	8000 98257	9	10	8000 99729	18	15
8000 64988	3	39	8000 70698	17	18	8000 86177	16	25	8000 94414	22	19	8000 98268	10	9	8000 A0192	19	2
8000 64988	7	83	8000 71230	8	14	8000 87120	5	3	8000 94415	22	38	8000 98269	10	6	8000 A0379	13	55
8000 65653	6	16	8000 71578	17	26	8000 87243	12	2	8000 94757	24	6	8000 98272	10	10	8000 A0381	13	76
8000 66101	7	52	8000 71620	14	13	8000 87812	17	15	8000 95341	24	6	8000 98275	10	5	8000 A0385	13	22
8000 66238	20	8	8000 71623	14	19	8000 87859	5	17	8000 96647	13	41	8000 98276	10	11	8000 A0387	13	21
8000 66395	2	45	8000 71806	22	13	8000 88073	4	19	8000 96721	3	33	8000 98278	9	1	8000 A0565	21	4
8000 66427	2	27	8000 72168	16	14	8000 88967	8	11	8000 96727	7	41	8000 98290	2	33	8000 A0633	13	51
8000 66428	2	7	8000 72268	15	26	8000 88968	8	12	8000 96728	6	19	8000 98372	20	22	8000 A0671	5	24
8000 66648	20	5	8000 72289	3	42	8000 89089	15	11	8000 96729	6	18	8000 98373	20	23	8000 A0692	24	14
8000 66802	1	7	8000 72290	3	43	8000 89572	24	26	8000 96747	6	42	8000 98375	19	10	8000 A0693	24	13
8000 66807	2	25	8000 72426	6	41	8000 89829	7	78	8000 96759	22	1	8000 98379	11	1	8000 A0931	18	19
8000 66858	5	19	8000 72427	6	11	8000 90052	7	60	8000 96796	3	30	8000 98390	21	2	8000 A0935	18	33
8000 67440	20	19	8000 72868	14	6	8000 90054	7	23	8000 96828	17	25	8000 98392	21	4	8000 A0936	18	17
8000 67449	5	18	8000 72884	14	3	8000 90056	7	79	8000 96832	17	7	8000 98393	21	21	8000 A1414	20	14
8000 67496	21	7	8000 73111	5	37	8000 90057	7	77	8000 96833	17	9	8000 98394	21	19	8000 A1415	20	15
8000 67545	21	13	8000 73140	12	3	8000 90561	16	23	8000 96835	17	30	8000 98395	21	5	8000 A1709	23	16
8000 67700	20	20	8000 73343	18	1	8000 91238	15	4	8000 96880	2	46	8000 98463	17	34	8000 A1761	19	3
8000 67744	2	6	8000 74016	14	42	8000 91288	1	9	8000 96881	2	54	8000 98464	1	17	8000 A2122	27	10
8000 67824	4	11	8000 75166	14	9	8000 91289	1	14	8000 96890	7	56	8000 98486	7	65	8000 A3191	13	74
8000 67970	11	5	8000 75584	2	17	8000 91479	13	19	8000 96907	12	42	8000 98489	15	5	8000 A3195	27	2
8000 67997	13	68	8000 75672	11	15	8000 91480	13	48	8000 96908	12	9	8000 98490	15	7	8000 A3540	12	18
8000 67997	14	12	8000 75780	3	2	8000 91610	13	21	8000 96928	23	11	8000 98491	15	8	8000 A3573	15	64
8000 68174	7	64	8000 76283	14	59	8000 92414	24	9	8000 96933	23	19	8000 98492	15	9	8000 A3622	2	41
8000 68195	6	10	8000 76338	18	10	8000 92797	23	12	8000 96937	24	8	8000 98493	15	10	8000 A3629	22	44
8000 68584	7	48	8000 76687	17	3	8000 92797	24	11	8000 96938	24	12	8000 98494	15	12	8000 A3631	1	19
8000 68686	7	17	8000 76688	17	2	8000 92822	2	4	8000 96940	24	19	8000 98495	15	20	8000 A3632	1	18
8000 68710	7	42	8000 77373	13	20	8000 92837	2	15	8000 96941	14	18	8000 98496	15	15	8000 A3633	1	20
8000 68905	2	19	8000 77391	9	3	8000 92838	2	18	8000 96944	14	18	8000 98497	15	16	8000 A3658	12	45
8000 68908	2	23	8000 77715	4	21	8000 92838	7	18	8000 97050	16	5	8000 98498	15	17	8000 A3662	13	1
8000 69036	5	41	8000 79015	1	11	8000 92907	2	1	8000 97052	16	1	8000 98499	15	18	8000 A3663	13	4
8000 69111	12	17	8000 79066	18	22	8000 92918	3	5	8000 97054	16	4	8000 98512	15	2	8000 A3666	13	50
8000 69125	18	2	8000 79072	18	16	8000 92944	7	51	8000 97590	15	1	8000 98514	15	13	8000 A3667	13	6
8000 69148	19	15	8000 79075	18	28	8000 92947	11	7	8000 97749	13	77	8000 98515	15	14	8000 A3668	13	13
8000 69149	19	7	8000 79077	5	2	8000 92948	11	6	8000 98176	2	42	8000 98517	15	19	8000 A3669	13	49
8000 69150	12	4	8000 79790	24	28	8000 92961	15	22	8000 98178	2	42	8000 98519	15	3	8000 A3670	13	5

DISEGNO DRAWING DESSIN ZEICHNUNG DIBUJO	TAVOLA DRAWING TABLE BILD TABLA	INDEX NO. POS. N. INDICE	DISEGNO DRAWING DESSIN ZEICHNUNG DIBUJO	TAVOLA DRAWING TABLE BILD TABLA	INDEX NO. POS. N. INDICE	DISEGNO DRAWING DESSIN ZEICHNUNG DIBUJO	TAVOLA DRAWING TABLE BILD TABLA	INDEX NO. POS. N. INDICE	DISEGNO DRAWING DESSIN ZEICHNUNG DIBUJO	TAVOLA DRAWING TABLE BILD TABLA	INDEX NO. POS. N. INDICE	DISEGNO DRAWING DESSIN ZEICHNUNG DIBUJO	TAVOLA DRAWING TABLE BILD TABLA	INDEX NO. POS. N. INDICE	DISEGNO DRAWING DESSIN ZEICHNUNG DIBUJO	TAVOLA DRAWING TABLE BILD TABLA	INDEX NO. POS. N. INDICE
8000 A3671	13	7	8A00 55241	18	11	8B00 33690	11	3	8D00 28183	4	2						
8000 A3673	14	1	8A00 55532	6	2	8B00 36022	6	38	8D00 36022	6	38						
8000 A3680	27	3	8A00 55903	18	13	8B00 38110	7	30	8D00 62797	15	30						
8000 A3681	27	13	8A00 59964	9	2	8B00 43715	5	4	8D00 62797	16	17						
8000 A3682	27	12	8A00 60415	2	51	8B00 44099	19	23	8D00 67545	21	14						
8000 A3685	23	6	8A00 60652	11	19	8B00 50322	3	47	8D00 86176	16	20						
8000 A3688	24	5	8A00 63644	2	43	8B00 66525	13	71	8D00 96719	2	35						
8000 A3691	19	1	8A00 65503	13	56	8B00 66850	5	12	8D00 A3517	12	7						
8000 A3699	17	10	8A00 67545	15	25	8B00 69282	19	25	8E00 30053	8	29						
8000 A3738	10	4	8A00 67997	13	52	8B00 71154	6	32	8E00 69056	12	38						
8000 A3740	12	47	8A00 68196	6	30	8B00 71154	7	11	8E00 86138	16	6						
8000 A3765	13	61	8A00 68201	6	28	8B00 78437	2	30	8E00 96718	2	34						
8000 A3786	23	8	8A00 72284	5	32	8B00 82879	23	3	8E00 96721	2	40						
8000 A3840	13	58	8A00 72425	6	39	8B00 82879	24	3	8E00 96721	3	32						
8000 A3842	27	11	8A00 72869	14	27	8B00 86138	16	13	8E00 99475	11	16						
8000 A3846	12	41	8A00 78326	18	23	8B00 91687	5	16	8E00 A3517	12	7						
8000 A3905	19	6	8A00 78765	2	31	8B00 95276	22	5	8F00 10789	3	46						
8000 A3911	5	14	8A00 79754	17	22	8B00 96717	7	49	8F00 28183	4	2						
8000 A3912	5	11	8A00 79785	24	27	8B00 96718	7	69	8F00 38110	7	30						
8000 A3913	5	21	8A00 83904	14	2	8B00 96720	6	44	8F00 96718	7	47						
8000 A3914	4	9	8A00 84665	12	11	8B00 96721	2	22	8F00 99475	11	14						
80A0 42349	20	16	8A00 86177	16	24	8B00 96721	2	39	8F00 A3517	12	7						
80A0 66222	2	50	8A00 87717	13	3	8B00 96721	3	31	8G00 96718	7	54						
80A0 67248	5	22	8A00 92876	23	17	8B00 96838	23	10	8G00 96718	9	6						
80A0 69551	15	32	8A00 92986	23	15	8B00 98185	10	4	8G00 96721	3	26						
80A0 73456	14	15	8A00 94010	20	17	8B00 98186	10	3	8G00 96837	24	16						
80A0 74388	14	7	8A00 94060	22	40	8B00 98388	21	1	8G00 A3517	12	7						
80A0 75671	11	9	8A00 95599	22	39	8B00 99475	5	15	8H00 28183	4	2						
80A0 77737	17	11	8A00 96721	2	52	8B00 A3517	12	7	8H00 36022	8	62						
80A0 96889	7	55	8A00 96724	7	20	8BA0 75330	17	4	8H00 70379	21	9						
80A0 A3612	17	1	8A00 96819	20	1	8BA0 77737	17	11	8I00 69056	12	39						
80B0 43928	12	10	8A00 96837	24	16	8C00 27690	7	59	8L00 66179	22	4						
80B0 84173	3	25	8A00 96930	23	21	8C00 28183	4	2	8L00 70379	21	10						
80B0 84174	3	16	8A00 96932	23	18	8C00 28327	13	59	8L00 96718	6	13						
80B0 87800	19	26	8A00 98185	10	4	8C00 36022	6	38	8S00 66179	18	20						
80C0 75766	2	24	8A00 98186	10	3	8C00 40796	24	17	8S00 68873	20	12						
80D0 60559	9	5	8A00 98379	11	1	8C00 43715	5	36	8S00 96718	6	7						
8A00 01815	12	5	8A00 98388	21	1	8C00 50322	3	47									
8A00 15960	2	47	8A00 98391	21	3	8C00 61121	14	20									
8A00 15960	2	53	8A00 A0546	19	12	8C00 62731	14	29									
8A00 15960	3	34	8A00 A2811	27	7	8C00 67545	19	20									
8A00 26846	24	20	8A00 A2812	27	6	8C00 67997	19	28									
8A00 28182	7	2	8A00 A2825	27	5	8C00 69112	12	15									
8A00 28183	4	2	8A00 A2826	27	4	8C00 94010	20	21									
8A00 36022	6	38	8A00 A3517	12	7	8C00 96718	7	50									
8A00 37003	7	26	8A00 A3630	22	45	8C00 96720	9	11									
8A00 38350	8	52	8A00 A3634	12	1	8C00 96721	3	18									
8A00 45395	4	25	8AA0 95696	13	66	8C00 96725	7	68									
8A00 48188	6	1	8AG0 69338	13	67	8C00 96837	24	16									
8A00 50322	3	47	8B00 26846	24	10	8C00 A3517	12	7									

**CATALOGO PARTI DI RICAMBIO - PARTS CATALOG
CATALOGUE PIECES DE RECHANGE - ERSATZTEILKATALOG
CATALOGO PIEZAS DE REPUESTO**

Husqvarna



***SMR 630 SEEL
REPLICA***

Part. N° 8000 A3633